

HALFEN CAST-IN CHANNELS

TECHNICAL PRODUCT INFORMATION

**NEW: HTA-CE 50/30P
and HTA-CE 40/22P.
With more load capacity**



HALFEN CAST-IN CHANNELS

CONCRETE

B 17.3-E

HALFEN CAST-IN CHANNELS

Contents



1 HALFEN Channels HTA-CE	7	
- Application examples	8	
- General	9 – 10	
- Materials/Corrosion protection	11 – 12	
- Installation/Assembly	13 – 14	
- Identification/Geometry	15	
- Product range	16 – 18	
- HALFEN Bolts HS/HSR	19 – 23	
- Available types	24	
- HTA-CS (Curved channels)	25	
- Calculation	26	
- Software	27 – 28	
- Dynamic loading	37	
2 HALFEN Channels HZA	29	
- Application examples	30	
- Product range	31	
- HALFEN HZS Bolts	32	
- Calculation	33 – 36	
- Dynamic loading	37	
3 HALFEN HGB Guard rail fixings	38	
- Application examples	39	
- General	40	
- Materials/Corrosion protection	41	
- Installation/Assembly	42	
- Product range	43	
- Dimensioning/ calculation	44 – 51	
4 HALFEN HTU Channels – fixings for trapezoid metal plates	52	
- Application examples	53	
- General/Materials	54	
- Installation/Assembly	55	
- Product range	56	
- Dimensioning	57	

NEW: HTA-CE 50/30P
and HTA-CE 40/22P.

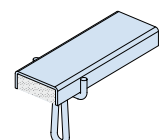
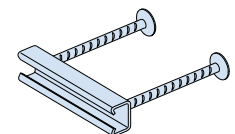
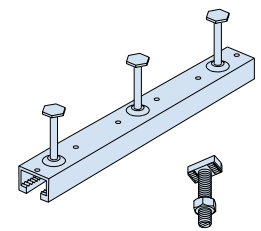
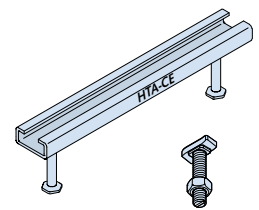

HALFEN CAST-IN CHANNELS

Contents



5 Roof and walls	58
- Application examples	59
- HALFEN HSF Rafter shoe	60
- HALFEN HNA Timber anchor	61
- Masonry connection-systems ML/BL	62 – 64
- HALFEN Dowels	63
- Firewall-Joints	65
- SPV Restraint with turnbuckle	66
- HKZ Restraint tie	67 – 68
- HVL Anchoring system	69
- HALFEN HKW Corner guard	70

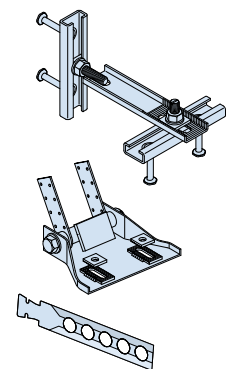

6 HALFEN HCW Curtain Wall	71
- Application examples	72
- General	73
- Product range	74 – 75
- HALFEN Channel HCW 52/34 for curtain wall connection	76 – 77
- HALFEN Channel HTA-R and HZA-R with rebar anchors	78
- Brackets HCW-ED and HCW-EW for front-of-slab installation	79 – 81
- Brackets HCW-B1 and HCW-B2 for top-of-slab installation	82 – 83

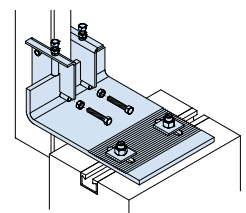

7 Accessories	84
- Nuts, washers	85
- Threaded rods, hexagonal bolts, couplers, ring nuts	86
- Clamping plates	87
- Framing channels HM/HZM/HL/HZL, type overview	88
- Framing channels HM/HZM/HL/HZL, application examples	89

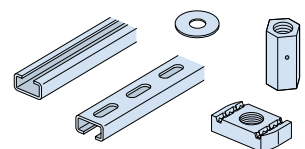

Appendix	
- Index	90
- Addresses/Contacts	91



APPLICATION EXAMPLES HALFEN CAST-IN CHANNELS

Areas of Application

CURTAIN WALL



Edificio Gas Natural, Barcelona, Spain

POWER STATIONS

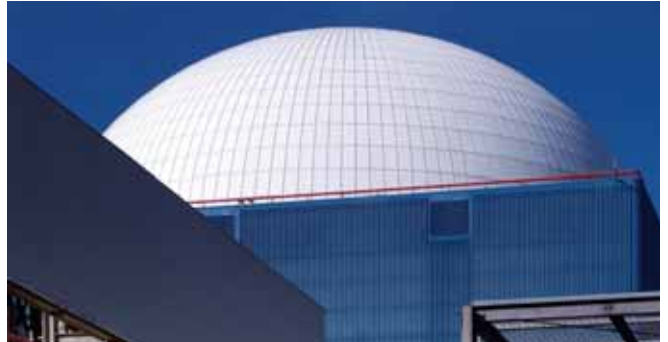

Power station

BRIDGES



Passerelle Simone de Beauvoir, Paris, France

SPORTS



Rheinenergiestadion, Cologne, Germany

LIFTS AND ELEVATORS



Lift fixings, guide rails

HTU Trapezoidal sheet panels



UPS Air Hub, Airport Cologne/Bonn, Germany

TUNNELS



Lötschberg-Base tunnel, Switzerland

ROOFS AND WALLS



Timber pitched roof construction

1 HTA-CE Channels
2 HZA Channels
3 HGB Channels
4 HTU Channels
5 Roof and Wall
6 Curtain Wall
7 Accessories

Better safe than sorry

The right channel for every application

Besides excellent adjustability HALFEN Cast-in channels save considerable installation time.

The result: faster construction and therefore cost saving. HALFEN Cast-in channels are the ideal basis for easy to install, adjustable connections. A foam strip filler stops the ingress of concrete into the channel.

HALFEN Channels are suitable for various types of construction connections, for example; façades, precast concrete elements, stadium seating, in civil engineering (fixing of tunnel signals) lift guide rails, crane runway, pipe fixings under bridges.

HALFEN fixing systems: The intelligent alternative to drilling and welding.

HALFEN HTA-CE Cast-in channels **NEW!**

Application

- fixing of all types of building components
- **NEW:** HTA-CE 50/30P and HTA-CE 40/22P with more load capacity.



Features

- adjustable
- hot-rolled profile; suitable for dynamic loads
- can be installed in concrete pressure and tensile-stress zones

HALFEN HZA Cast-in channels, serrated

Application

- fixing of all types of building components



Features

- adjustable
- load transmission in longitudinal channel direction
- can be installed in concrete pressure and tensile-stress zones
- suitable for dynamic loads*

*applies for all hot-rolled and serrated DYNAGRIP® channels

HALFEN HZA-PS Cast-in channels, serrated

Application

- fixing of all types of building components in safety critical areas of nuclear power stations and similar nuclear facilities



Features

- as HZA Channels
- suitable for exceptional load cases caused by earthquake, plane crashes or explosions – for concrete crack widths up to 1.5 mm

HALFEN HGB Handrail connections

Application

- fastening banisters on the thin front face of balcony slabs



Features

- the special ribbed head anchor provides good load transfer in thin concrete elements

Channel range and steel load capacity/tension

HALFEN has enhanced its anchor channel range; two new channel profiles are now available: HTA-CE 40/22P and HTA-CE 50/30P.

The different profiles can now cover a significantly higher load range, providing up to 45% more load capacity. Therefore allowing more economical solutions.

Load capacities for HALFEN Channels hot-rolled, serrated

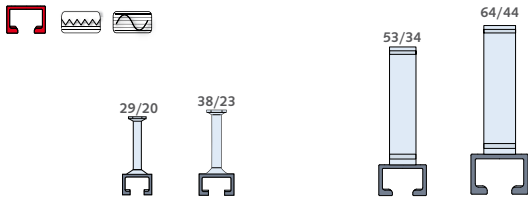

Load capacities for HALFEN Channels hot-rolled

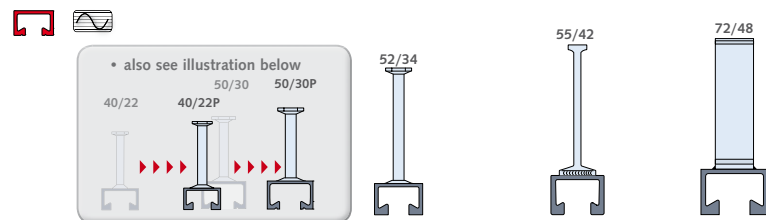

Load capacities for HALFEN Channels cold-rolled, serrated

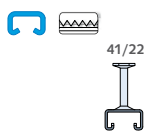

Load capacities for HALFEN Channels cold-rolled

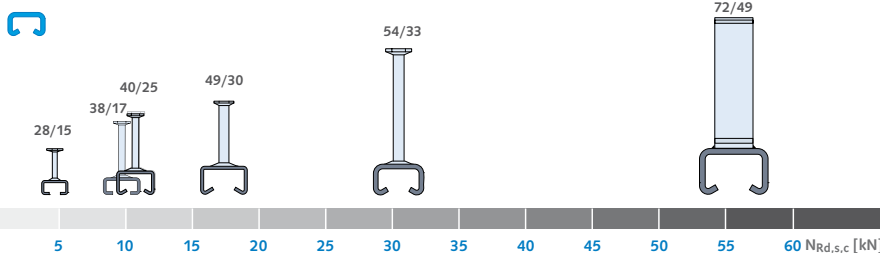

NEW!

HALFEN Anchor channels – with increased load capacity!

New: HTA-CE 40/22P – Previously, for a load of $N_{Ed} > 11.1$ kN the next larger channel had to be selected; a HTA-CE 50/30 (with $N_{Rd,s,c} = 17.2$ kN) instead of a HTA-CE 40/22.

Now in most cases the HTA-CE 40/22P (with $N_{Rd,s,c} = 16.1$ kN) is sufficient. This also allows a more economical screw to be used; a HS 40/22 instead of a HS 50/30.

HTA-CE 50/30P – Previously, for a load of $N_{Ed} > 17.2$ kN the next larger channel had to be selected; a HTA-CE 52/34 (with $N_{Rd,s,c} = 30.6$ kN) instead of a HTA-CE 50/30. Now in most cases the HTA-CE 50/30P (with $N_{Rd,s,c} = 21.7$ kN) is sufficient.

On-site safety: In many projects, different applications are therefore possible using a single channel profile. This reduces the risk of confusion when using different channels in one project. Furthermore, fewer bolt/screw types are required.

Minimal channel size for economical reinforcement layouts:

In respect to its load bearing capacity the new HTA-CE 40/22P can almost always be used instead of a HTA-CE 50/30. With a height of only 23 mm, the new channel is almost always installed completely in the required concrete cover. This allows more efficient reinforcement planning (mesh and supplementary reinforcement).

European certification:

The new HTA-CE 40/22P and HTA-CE 50/30P types are included in ETA-16/0453 and are therefore certified for use, without restrictions, in 30 European countries.

HTA-CE with improved load capacity (illustrated: Steel load capacity/tension)

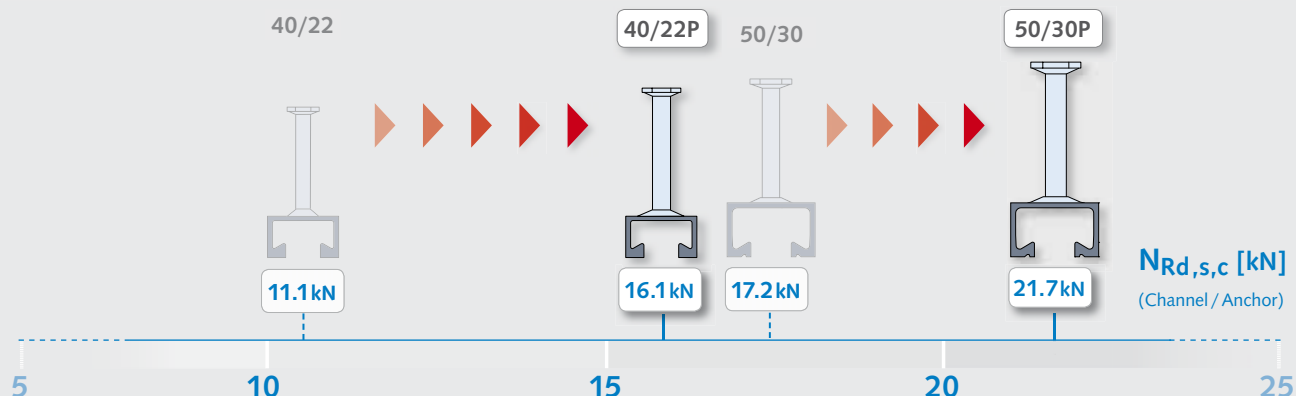

HALFEN Cast-in channels HTA-CE

The advantages at a glance

A part from excellent adjustability, HALFEN Cast-in channels save considerable installation time. The result: faster construction and therefore reduced overall cost.

Safe and reliable

- no damage to the reinforcement
- approved for fire-resistant structural elements
- suitable for use in concrete pressure and tensile stress zones
- high corrosion resistance steels available
- suitable for dynamic loads
- European Technical Approval/Assessment (ETA)
- precise calculation with HALFEN-Software

Quick and economical

- adjustable anchoring
- bolts instead of welding
- maximum efficiency when installing matrices and rows
- cost effective installation using standard tools
- optimised pre-planning reduces construction time
- large range of types available for various requirements
- no noise, no vibration during installation, therefore no health hazards

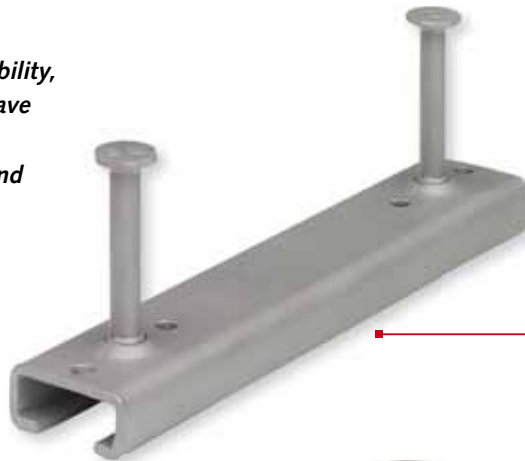

HALFEN HTA-CE Channels cold-rolled



HALFEN HTA-CE Channels hot-rolled



suitable for dynamic loads

NEW: HTA-CE 50/30P and HTA-CE 40/22P with more load capacity.



What does HTA-CE involve?

HTA-CE signifies that the channel is CE marked. HALFEN as the manufacturer declares, that it is responsible for the conformity of the product with the (DoP - Declaration of performance), and that the specified performance and compliance with all relevant European legislation has been applied.

HALFEN CAST-IN CHANNELS HTA-CE

Application Examples

CURTAIN WALL



Fixings for curtain wall façades

CURTAIN WALL



Fixings for curtain wall façades

SPORTS



Seat fixings, St. Jakob-Park, Basel, Switzerland

LIFTS/ELEVATOR FIXINGS



Fixing guide rails with HALFEN Channels

NOISE BARRIERS



Fixings of noise barriers to concrete posts

BRIDGES



Fixings for drainage systems

UTILITY TUNNELS



Utility fixings in TBM tunnels with curved anchor channels

TUNNELS



Fixing of overhead cables in railway tunnels

1 HTA-CE Channels
2 HZA Channels
3 HGB Channels
4 HTU Channels
5 Roof and Wall
6 Curtain Wall
7 Accessories

HALFEN CAST-IN CHANNELS HTA-CE

General

Verification method according to CEN/TS 1992-4 / EOTA TR 047 / EN 1992-4

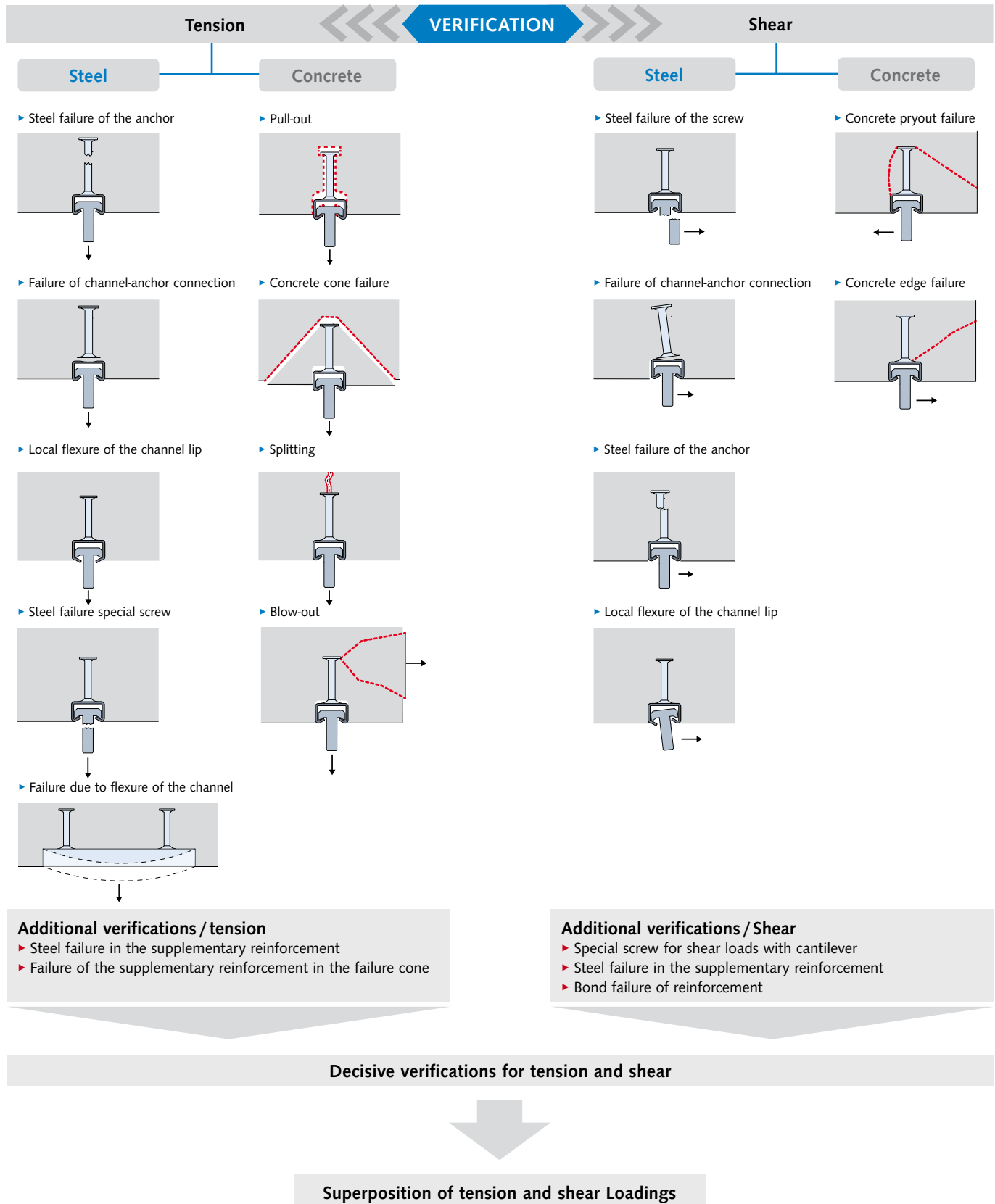

1 HTA-CE Channels
2 HZA Channels
3 HGB Channels
4 HTU Channels
5 Roof and Wall
6 Curtain Wall
7 Accessories

HALFEN CAST-IN CHANNELS HTA-CE

General

1 Fire-resistance

Verification of anchorages for fire load must take the specifications of the Technical Reports TR 020 into account. "Evaluation of anchorage in concrete with regards to fire resistance". The corresponding characteristic values can be found in the annexes of ETA-09/0339 and ETA-16/0453.

The approvals can be downloaded from our website www.halfen.com ▶ **Brochures**
▶ **Approval** ▶ **Fixing systems**.

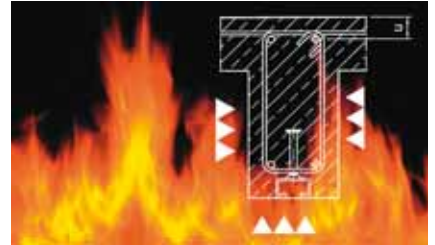

2 Material fatigue

All stated resistance values ΔF are specified according to general building approval Z-21.4-34 (see page 37).

ETA values for HTA-CE 52/34 can be found in ETA-09/0339.

Values for HTA-CE 40/22P and HTA-CE 50/30P can be found in ETA-16/0453.

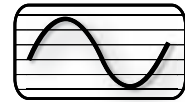

3 Quality

Quality is the outstanding feature of our products. HALFEN materials and products are subjected to the most stringent quality control procedures.

A quality inspection by the DNV GL* has verified that our quality management system meets the requirements of the ISO 9001:2015 standard.

**merger of DNV (Det Norske Veritas) and GL (Germanischer Lloyd) in 2013*



Certificate no. 202384-2016-AQ-GER-DAkks

4 EPD

An EPD® (Environmental Product Declaration) provides transparent and comparable ecological data which helps to evaluate the sustainability of a building. Already during the planning phase the data provided here is of great significance for architects and planners. The data provided also helps to ensure the high demands on the environmental performance of the building are met.



5 BIM

HALFEN already has considerable experience as a BIM partner and has successfully completed various projects using the BIM methodology. All HALFEN engineers are trained to properly supervise this process. With a combination of wide experience and highly-trained engineers the increasing demand for BIM projects can be efficiently met. Examples of previous projects developed using BIM can be found at www.halfen.com ▶ **Service** ▶ **BIM** ▶ **BIM references**.

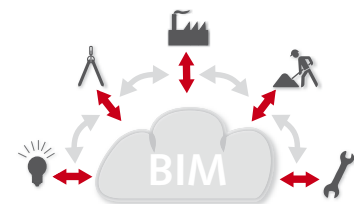

HTA-CE Channels
HZA Channels
HGB Channels
HTU Channels
Roof and Wall
Curtain Wall
Accessories

HALFEN CAST-IN CHANNELS HTA-CE

Materials / Corrosion Protection

Hot-dip galvanized FV:

Dipped in a galvanizing bath, with a temperature of approx. 460 °C, this is a method used primarily for open-profile channels.

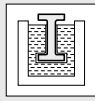

Zinc galvanized GVs:

HALFEN T-bolts are electrogalvanized and coated with a CrVI-free thick layer passivation.

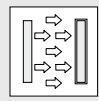

HALFEN Cast-in channels, steel, hot-dip galvanized

	Steel		
	Material	Standard	Zinc coat
Channel profile	1.0038	DIN EN 10 025-2 ①	FV: ≥ 55 µm
	1.0044	DIN EN 10 025-2 ①	FV: ≥ 55 µm
Bolt anchor B6	Steel	DIN EN 10263 or DIN EN 10269	FV: ≥ 55 µm
Weld-on anchor	Steel	DIN EN 10 025-2	FV: ≥ 55 µm

① Steel according to DIN EN 10 025-2 and HALFEN specification

HALFEN Bolts, galvanized steel

	Steel		
	Material	Standard	Zinc coat
Bolt	Steel (Sc) 4.6 or (Sc) 8.8	DIN EN ISO 898-1	FV: ≥ 50 µm GVs: ≥ 12 µm
Hexagonal nut	Steel (Sc) 5 or (Sc) 8	DIN EN 898-2	FV: ≥ 50 µm GVs: ≥ 12 µm
Washer	Steel	DIN EN ISO 7089, DIN EN ISO 7093	FV: ≥ 50 µm GVs: ≥ 12 µm

(Sc) = Strength class

Stainless steel (NR):

Chromium is the most important alloy element in stainless steel. A specific chromium concentration ensures the generation of a passive layer on the surface of the steel that protects the base material against corrosion. This explains the high corrosion resistance of stainless steel.

Materials:

- WB** = Steel mill finished
- FV** = Steel hot-dip galvanized
- GVs** = Steel zinc galvanized (with special coating)
- A4** = Steel, stainless 1.4571 / 1.4404 / 1.4578
- HCR** = Steel, stainless 1.4547 / 1.4529

HALFEN Cast-in channels, stainless steel

	Stainless steel		
	Material	Standard	Corrosion resistance class ②
Channel profile	1.4404 or 1.4571 <input checked="" type="checkbox"/>	DIN EN 10 088	III
	1.4529 or 1.4547 <input checked="" type="checkbox"/>		V
Bolt anchor B6	1.4404, 1.4571 or 1.4578 <input checked="" type="checkbox"/>	DIN EN 10 088	III
	1.4529 or 1.4547 <input checked="" type="checkbox"/>		V
Weld-on anchor	1.4404 or 1.4571 <input checked="" type="checkbox"/>	DIN EN 10 088	III
	Steel ③		DIN EN 10 025-2

HALFEN Bolts, stainless steel

	Stainless steel		
	Material	Standard	Corrosion resistance class ②
Bolt	1.4404, 1.4571, 1.4578 (A4-50 or A4-70) <input checked="" type="checkbox"/>	DIN EN 3506-1 and DIN EN 10 088	III
	1.4529, HCR-50 <input checked="" type="checkbox"/>		V
Hexagonal nut	1.4404, 1.4571, 1.4578 (A4-50, A4-70) <input checked="" type="checkbox"/>	DIN EN 3506-2 and DIN EN 10 088	III
	1.4529, HCR-50 <input checked="" type="checkbox"/>		V
Washer	1.4404, 1.4571 <input checked="" type="checkbox"/>	DIN EN 10 088	III
	1.4529 or 1.4547 <input checked="" type="checkbox"/>		V





② See EN 1993-1-4, table A.3

③ Corrosion protection of mill finished anchor, see page 12

HALFEN CAST-IN CHANNELS HTA-CE

Materials / Corrosion Protection

Corrosion protection requirements

Material and applications				
Description	1	2	3	4
	Dry interior-rooms	Damp interior-rooms	Medium corrosion level	High level of corrosion
Definition of application areas	Anchor channels may only be used in components in indoor environments. For example: living and office spaces, schools; hospitals, commercial shops with the exception of wet rooms as in column 2.	Anchor channels may also be used in components in areas with normal humidity For example: kitchens, bathrooms and laundry-rooms in residential buildings. Exceptions: where permanent steam is present and under water.	Anchor channels may also be used in outdoor environments (including industrial environments and coastal regions) or in wet rooms, if conditions are not especially aggressive (for example: continual immersion in sea water etc. as in column 4).	Anchor channels may also be used in exceptionally aggressive environments (for example: continual immersion in sea water) or in seawater spray zones, chloride environments in swimming pools or in environments with an extremely aggressive chemical atmosphere (for example: flue gas desulfurization plants or road tunnels where de-icer systems are in use).
Channel profile 	Steel 1.0038, 1.0044; EN 10025 Hot-dip galvanized $\geq 55 \mu\text{m}$ ⑥	Steel 1.0038, 1.0044; EN 10025 Hot-dip galvanized $\geq 55 \mu\text{m}$ ⑥ Stainless steel 1.4307, 1.4567, 1.4541; EN 10088	Stainless steel 1.4404, 1.4571, 1.4062, 1.4162, 1.4362 EN 10088	Stainless steel 1.4462 ②, 1.4529, 1.4547 EN 10088
Anchor 	Steel 1.0038, 1.0214, 1.0401, 1.1132, 1.5525; EN 10263, EN 10269 Hot-dip galvanized $55 \mu\text{m}$ ⑥	Steel 1.0038, 1.0214, 1.0401, 1.1132, 1.5525; EN 10263, EN 10269 Hot-dip galvanized $\geq 55 \mu\text{m}$ ⑥ Stainless steel 1.4307, 1.4567, 1.4541; EN 10088	Stainless steel 1.4404, 1.4571, 1.4362, 1.4578 EN 10088 Mill finish, 1.0038 ③	
Special HALFEN Bolts with shaft and screws in accordance with EN ISO 4018 	Steel strength class 4.6/8.8 EN ISO 898-1 Zinc galvanized $\geq 5 \mu\text{m}$ ④	Steel strength class 4.6 / 8.8; EN ISO 898-1, Hot-dip galvanized $\geq 50 \mu\text{m}$ ① ⑤ Stainless steel, strength class 50, 70 1.4307, 1.4567, 1.4541 EN ISO 3506-1	Stainless steel Strength class 50, 70 1.4404, 1.4571, 1.4362, 1.4578 EN ISO 3506-1	Stainless steel Strength class 50, 70 1.4462 ②, 1.4529, 1.4547 EN ISO 3506-1
Washers EN ISO 7089 and EN ISO 7093-1 Product classification A, 200 HV 	Steel EN 10025 Zinc galvanized $5 \mu\text{m}$ ④	Steel EN 10025 Hot-dip galvanized $\geq 50 \mu\text{m}$ ① ⑤ Stainless steel Steel grade A2, A3; EN ISO 3506-1	Stainless steel Steel grade A4, A5 EN ISO 3506-1	Stainless steel 1.4462 ②, 1.4529, 1.4547 EN ISO 3506-1
Hexagonal nut EN ISO 4032 	Steel strength class 5/8 EN ISO 898-2 Zinc galvanized $5 \mu\text{m}$ ④	Steel strength class 5/8 EN ISO 898-2 Hot-dip galvanized $\geq 50 \mu\text{m}$ ① ⑤ Stainless steel, strength class 70, 80 Steel grade A2, A3 EN ISO 3506-2	Stainless steel Strength class 70, 80 Steel grade A4, A5 EN ISO 3506-2	Stainless steel Strength class 70, 80 1.4462 ②, 1.4529, 1.4547 EN ISO 3506-2
① or zinc galvanized with special coating $\geq 12 \mu\text{m}$		④ Zinc galvanized in accordance with EN ISO 4042		
② 1.4462 not suitable for swimming baths		⑤ Hot-dip galvanized in accordance with EN ISO 10684		
③ Steel in accordance with EN 10025, 1.0038 not for Anchor channels 28/15 and 38/17		⑥ Hot-dip galvanized in accordance with EN ISO 1461		

HALFEN Channels (NR) mill finish welded-on anchors

Corrosion protection of the mill finished weld-on anchor is based on the following concrete cover c:

Profile HTA-CE	40/22P 40/25	52/34 54/33 50/30P 49/30	55/42	72/48 72/49
Concrete cover c [mm]	35	40	50	60

The minimum concrete cover depends on local environmental conditions and bid specifications.

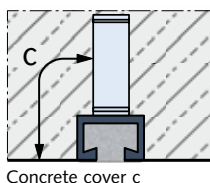

HALFEN Channels (NR) made completely in stainless steel

The HALFEN Cast-in channels "entirely of stainless steel" are not restricted to any minimum concrete cover as no relevant corrosion occurs.

Areas of application

- bridge and tunnel construction (fastening of pipes, etc.)
- construction of sewage treatment plants (fixing of spillovers)
- chemical industry (installations exposed to aggressive substances)
- ventilated façades, e.g. masonry renders
- also for all structural reinforced concrete elements with higher demands on the concrete cover

HALFEN Channel made in stainless steel – HCR

The high corrosion resistance (HCR) HALFEN Cast-in channels are mandatory when high concentrations of chlorides, sulphur and nitrogen oxides are present.

Areas of application

- road tunnels
- structures in salt water
- indoor swimming pools
- areas not routinely cleaned
- poorly ventilated parking garages
- in narrow, major city streets

HALFEN CAST-IN CHANNELS HTA-CE

Installation/Assembly

1.1 Delivery and identification

HALFEN can supply ready to install short channels and standard lengths.

Product identification:

- ① on channel inside
- ② also on channel side

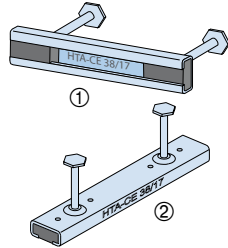

1.2 Installing to formwork

If required, HALFEN Cast-in channels can also be cut to size on site.

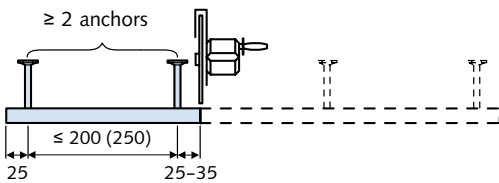

2.1 Fixing to the formwork

Timber formwork

2.1.1 with nails

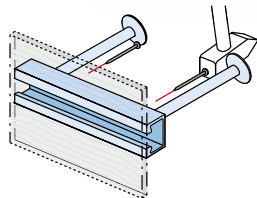
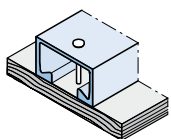

2.1.2 with staples

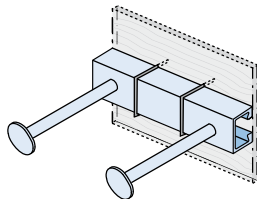
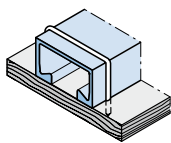

Steel formwork

2.1.3 aluminium rivets

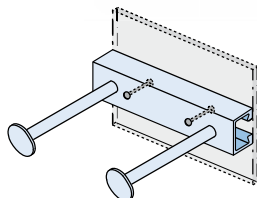
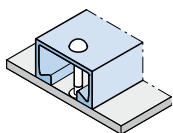

2.1.4 HALFEN Bolt and nut

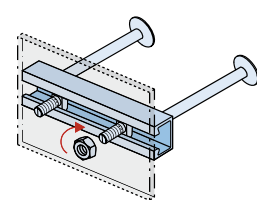
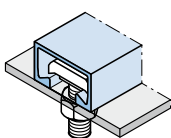

2.1 Fixing to the formwork, continued

Steel formwork

2.1.5 HALFEN HFK Fixing cone

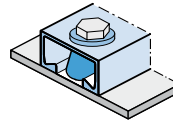

2.2 Top face installation

2.2.1

directly to reinforcement:
with tying wire

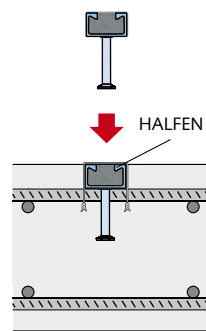

2.2.2

with HALFEN HCP ChanClip

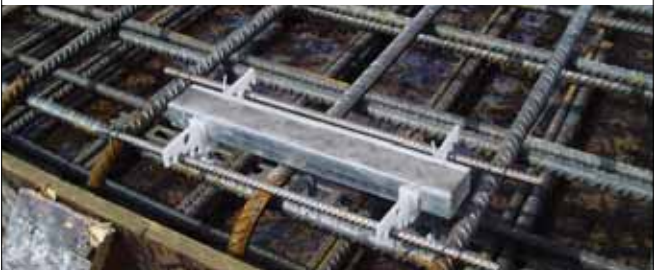
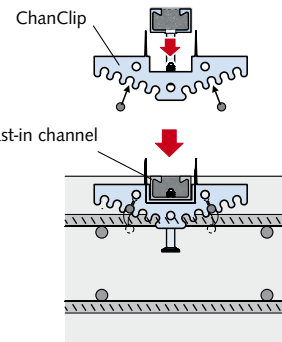

2.2.3 Installation using an auxiliary aid

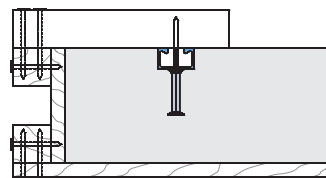

HALFEN CAST-IN CHANNELS HTA-CE

Installation/Assembly

1 HTA-CE Channels

3.1 Removing the filler

Strip filler, available in two versions:



KF - PE strip filler with reinforcement layer



KF - PE strip filler

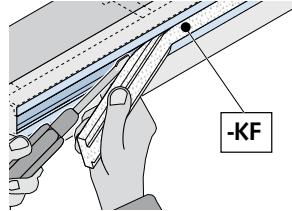

Removing the strip filler

Grip the strip filler at one end and pull out in one piece by hand, use a tool, e.g. a screwdriver.

2 HZA Channels

4.1 Installing HALFEN bolts

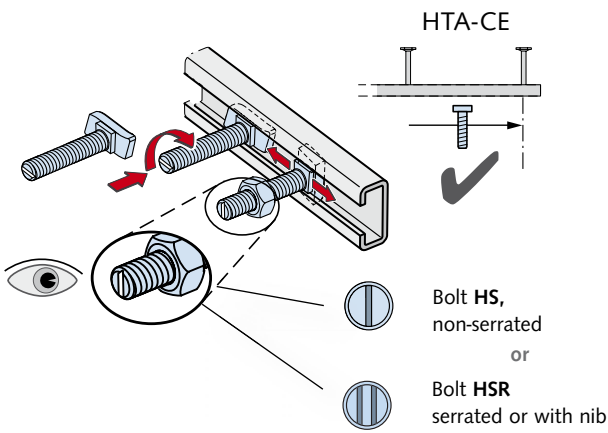

Safe assembly with HALFEN Cast-in channels

HALFEN Bolts can be inserted anywhere in the channel slot, turned 90° and then locked in place by tightening the nut. Do not position bolts at channel ends past the last anchor. On channels with bolt anchors, the anchor locations are visible through the channel slot.

Check

Bolts: After installation check that the bolts are properly aligned; the notch or notches in the tip of the shank must be at right angles to the longitudinal axis of the channel.

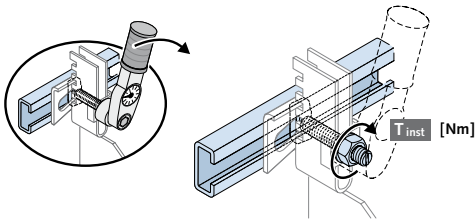

Fixings

The bolt heads must sit flush on both lips of the anchor channel and be secured by tightening the nut with a torque wrench with the required value. Observe the torque values in the tables on page 22.

3 HGB Channels

4 HTU Channels

5 Roof and Wall

Direct attachment ①

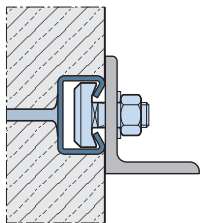

Surface-flush installation

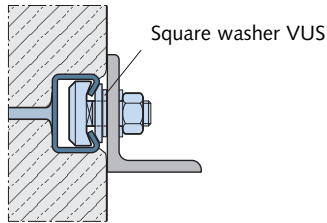

Non-flush installation

- ① If the front surface of the channel is set back from the concrete surface, the attached structure must be shimmed with a washer (VUS). In case of shear stress, add bolt flexure to the tensile force.

Stand-off installation ②

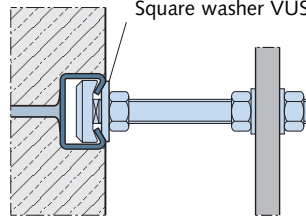

- ② Always install a square washer for stand-off installations.

Example:

HALFEN Channel: HTA-CE 49/30
 HALFEN Bolt: HS 50/30 - M16
 Washer: VUS 49/30 - M16

6 Curtain Wall

7

Accessories



Assembly instructions on the internet

Multi-language assembly instructions can be found at www.halfen.com ▷ Brochures ▷ Installation Instructions. Or scan the code and select the required document.

HALFEN CAST-IN CHANNELS HTA-CE

Identification / Geometry

Identification

Channel material	Type identification
1.0038 / 1.0044	HTA-CE 38/17
A2: 1.4307	HTA-CE 38/17 - A2
A4: 1.4404 / 1.4571	HTA-CE 38/17 - A4
HCR: 1.4529 / 1.4547	HTA-CE 38/17 - HCR

Type identification:

- ① Inside surface, bottom of the channel.
- ② Additionally on channel side

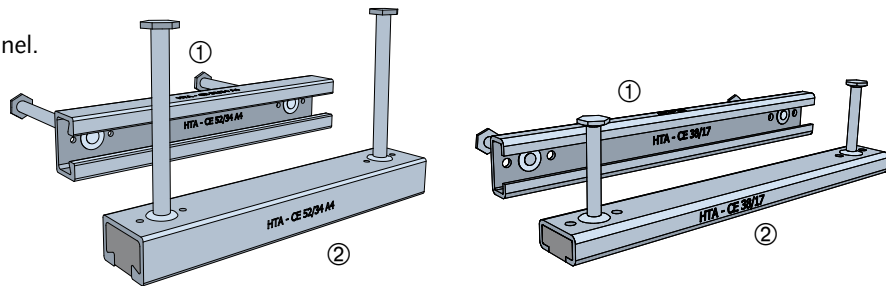

Minimum edge distances and minimum bolt spacing

Anchors must be installed at a minimum distance from the component edges. The distance depends on the selected channel profile and the corresponding HALFEN T-head bolt.

According to the ETA, the spacing between bolts s_s must not be less than $5 \times d_s$. Reduction of the load bearing capacity is required if $s_s < s_{slb}^*$ (see table on page 16).

* s_{slb} = centre distance of the bolts $N_{Rd, s, l}$

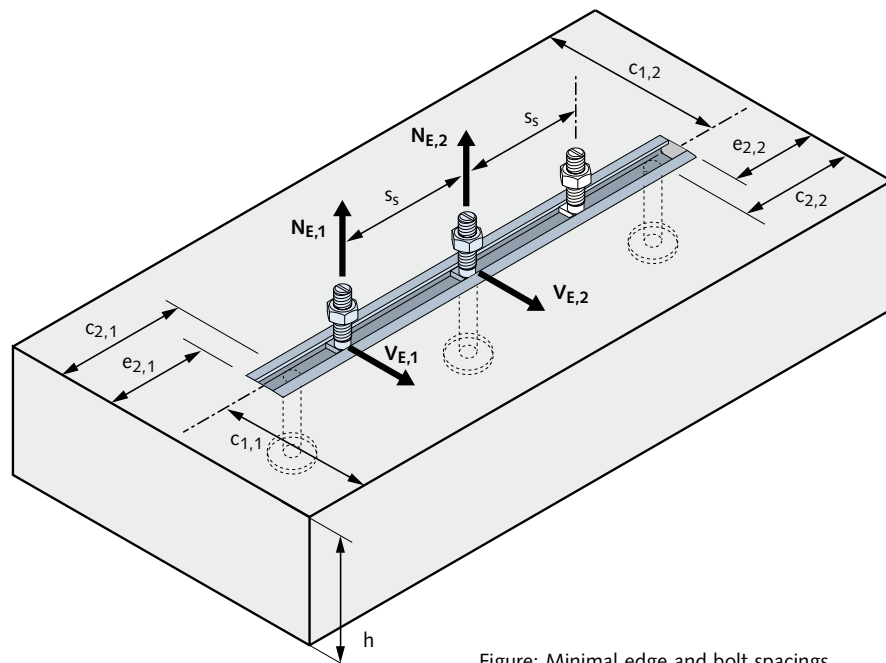

Figure: Minimal edge and bolt spacings

Edge and bolt spacing [mm]

HTA-CE Profiles	M	$s_{s,min}$	c_{min}	e_{min}
28/15	6	30	40	15
	8	40	40	15
	10	50	40	15
	12	60	40	15
38/17	10	50	50	25
	12	60	50	25
40/25 40/22P	10	50	50	25
	12	60	50	25
	16	80	50	25
49/30	10	50	75	50
	12	60	75	50
	16	80	75	50
50/30P	10	50	75	40
	12	60	75	40
	16	80	75	40
52/34 54/33	10	50	100	65
	12	60	100	65
	16	80	100	65
55/42	10	50	100	65
	12	60	100	65
	16	80	100	65
72/49 72/48	10	50	100	65
	12	60	100	65
	20	100	100	65
	20	100	150	115
	24	120	150	115
	27	135	150	115
	30	150	150	115

HALFEN CAST-IN CHANNELS HTA-CE

Product Range: Overview of Channels + Bolts

Identification values HTA-CE						
Profile	HTA-CE 72/48	HTA-CE 72/49	HTA-CE 55/42	HTA-CE 52/34	HTA-CE 54/33	
Type	hot-rolled	cold-rolled	hot-rolled	hot-rolled	cold-rolled	
Geometry HALFEN Channels HTA-CE						
<p>Note: observe the installation height h_{inst}</p>						
Material	Steel	■		■	■	■
	A4	■	■	■	■	
	HCR					
Bolts	HS 72/48	HS 72/48	HS 50/30	HS 50/30	HS 50/30	
Threads	M20 - M 30	M20 - M30	M10 - M20	M10 - M20	M10 - M20	
s_{slb} [mm]	129	129	109	88	88	
Profile load capacity						
$N_{Rd,s,l}$ [kN]	55.6	55.6	44.4	36.1	30.6	
$V_{Rd,s,l}$ [kN]	72.2		57.8	39.7		
$M_{Rd,s,flex}$ [Nm]	Steel	7472	-	2933	2595	
	NR	7630	7493	2996	2595	
Geometry						
h_{inst} [mm] ① ②	(191)	(193)	182 (185)	162 (164)	161 (164)	
b_{ch} [mm]	72	72	54.5	52.5	54	
h_{ch} [mm]	48.5	49	42	33.5	33	
I_y [mm ⁴]	Steel	349721	293579	187464	93262	72079
	NR					
h_{ef} [mm]	179	179	175	155	155	
c_{min} [mm]	150	150	100	100	100	
<p>* Concrete load capacity has to be verified for each individual case (taking the geometric boundary conditions into account). c_{min} = minimal spacing channel/concrete edge $N_{Rd,s,l}$ = channel lip load capacity (tension) ① Nominal size and tolerance NR = Stainless steel $V_{Rd,s,l}$ = channel lip load capacity (shear) ② () value in brackets is for weld-on I-anchors s_{slb} = axial spacing for bolts for $N_{Rd,s,l}$ Materials: See page 11</p>						

HALFEN CAST-IN CHANNELS HTA-CE

Product Range: Overview of Channels + Bolts

HTA-CE 50/30P NEW!	HTA-CE 49/30	HTA-CE 40/22P NEW!	HTA-CE 40/25	HTA-CE 38/17	HTA-CE 28/15
hot-rolled	cold-rolled	hot-rolled	cold-rolled	cold-rolled	cold-rolled

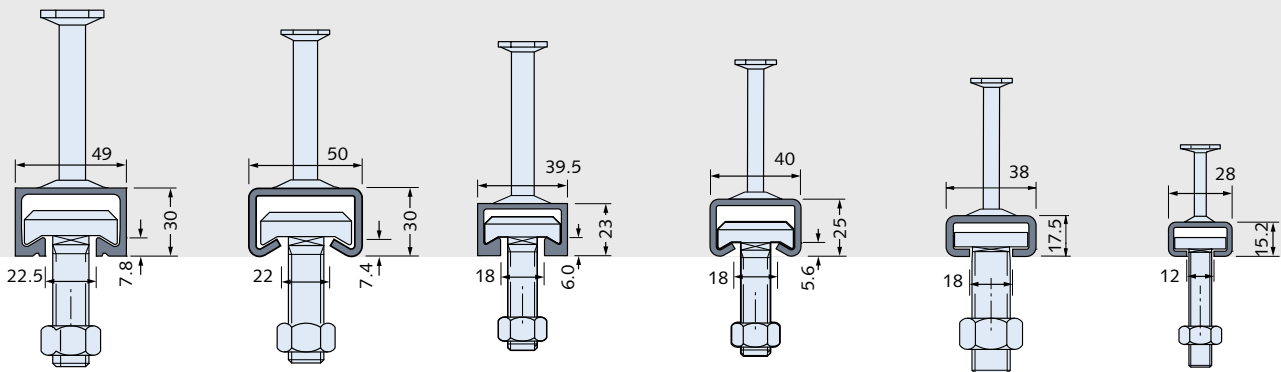

	■	■	■	■	■	■
	■	■	■	■	■	■
		☒			☒	☒
	HS 50/30	HS 50/30	HS 40/22	HS 40/22	HS 38/17	HS 28/15
	M10 - M20	M10 - M20	M10 - M16	M10 - M16	M10 - M16	M6 - M12
	98	81	79	65	52	42
	21.7	17.2	19.4	11.1	10.0	5.0
	22.4					
	2437	1455	1208	956	504	276
	2743	1485	1358	931	516	282
	112 (161)	103 (101)	97 (154)	89 (89)	81 (82)	50 (79)
	49	50	39.5	40	38	28.0
	30	30	23	25	17.5	15.25
	52575	41827	19859	20570	8547	4060
			19859	19097		
	106	94	91	79	76	45
	75	75	50	50	50	40

HALFEN CAST-IN CHANNELS HTA-CE

Product Range

Standard product range

The standard HALFEN Cast-in channel product range with European Technical Approval is listed in the following table. See also current HALFEN Price list.

Other lengths are available on request. Also see table below: Project related orders "Standard fixed lengths".

Supplied lengths and number of anchors					
Length [mm] / Number of anchors					
HTA-CE 72/48	HTA-CE 72/49	HTA-CE 55/42	HTA-CE 40/25, 50/30P, 49/30, 52/34, 54/33	HTA-CE 40/22P	HTA-CE 28/15, 38/17
150/2	150/2	150/2	150/2	150/2	100/2
200/2	200/2	200/2	200/2	200/2	150/2
250/2	250/2	250/2	250/2	250/2	200/2
300/2	300/2	300/2	300/2	300/2	250/2
350/3	350/3	350/3	350/3	350/3	300/3
400/3	400/3	400/3	400/3	400/3	350/3
550/3	550/3	550/3	550/3	550/3	450/3
1050/5	1050/5	1050/5	800/4	800/4 ^②	550/4
6070/25		6070/25	1050/5	1050/5	850/5
			3030/13 ^①	1300/6 ^②	1050/6
			6070/25	1550/7 ^②	3030/16
				1800/8 ^②	6070/31
				2050/9 ^②	
				2300/10 ^②	
				2550/11 ^②	
				3030/13 ^②	
				6070/25	
Anchor spacing ≤ 250 mm					Anchor spacing ≤ 200 mm

① Does not apply to HTA-CE 52/34, HTA-CE 54/33
 ② Does not apply to HTA-CE 40/22P - A4

Standard fixed lengths – Project related orders

Supplied lengths and number of anchors – Project related orders							
HTA-CE 28/15, HTA-CE 38/17				HTA-CE 40/22P, 40/25, 49/30, 50/30P, 52/34, 54/33, 55/42, 72/48, 72/49			
Length [mm] / Number of anchors				Length [mm] / Number of anchors			
1250/7	1450/8	1650/9	1850/10	1050/5	1300/6	1550/7	1800/8
2050/11	2250/12	2450/13	2650/14	2050/9	2300/10	2550/11	2800/12
2850/15	3030/16	3250/17	3450/18	3030/13	3300/14	3550/15	3800/16
3650/19	3850/20	4050/21	4250/22	4050/17	4300/18	4550/19	4800/20
4450/23	4650/24	4850/25	5050/26	5050/21	5300/22	5550/23	5800/24
5250/27	5450/28	5650/29	5850/30	–	–	–	–
Anchor spacing ≤ 200 mm				Anchor spacing ≤ 250 mm			

HALFEN CAST-IN CHANNELS HTA-CE

HALFEN Bolts HS

HALFEN Bolts - Type HS



Standard HALFEN Bolts (no nib or serration) for all profile types HTA-CE

- two direction load capacity
- identified on bolt tip with 1 notch

- HALFEN 4.6** Strength class 4.6 / 8.8 galvanized (GVs) or hot-dip galvanized (FV)
- HALFEN A4-70** Material grade A4-50 / A4-70 Stainless steel
- HALFEN HCR50** Strength class 50 Stainless steel (1.4529/1.4547)

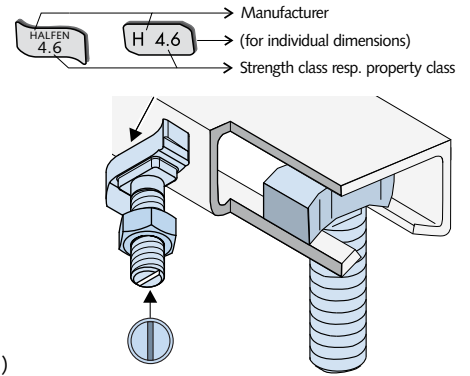

Calculating the bolt length l_{req} for HALFEN Bolts

$$l_{erf} = t_{fix} + f + h + v_{min}$$

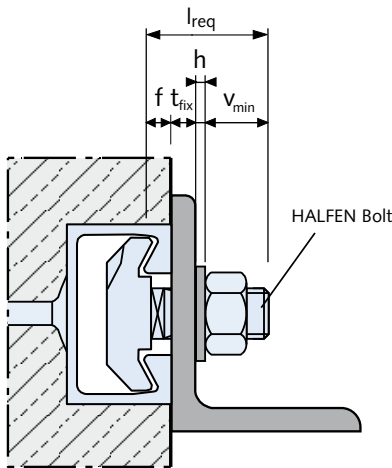

Dimensions v_{min}	
Bolt diameter	v_{min} [mm]
M6	11.0
M8	12.5
M10	14.5
M12	17.0
M16	20.5
M20	26.0
M24	29.0
M27	31.5
M30	33.5

Lip dimensions f	
Channel profile	f [mm]
28/15	2.25
38/17	3.0
40/22P	6.0
40/25	5.6 / 5.4 ^①
49/30	7.39
50/30P	7.85
52/34	10.5
54/33	7.9
55/42	12.9
72/48	15.5
72/49	9.9

- l_{req} = required bolt length
- t_{fix} = thickness of clamped component
- f = profile lip height
- h = washer thickness
- v_{min} = nut height EN ISO 4032 + overhang approximately 5 mm (for M20: 7 mm)

Bolt design values

The table on the right lists the design resistance of HALFEN Bolts with different thread diameters, materials and strength classes.

$N_{Rd,s,s}$ is the resistance against tension loads, $V_{Rd,s,s}$ is the the resistance against shear loads and $M^0_{Rd,s,s}$ is the flexural resistance when subjected to transverse load induced with a cantilever.

Design resistance										
Material / Strength class		M6	M8	M10	M12	M16	M20	M24	M27	30
4.6	$N_{Rd,s,s}$ [kN]	4.0	7.3	11.6	16.9	31.4	49.0	70.6	91.8	112.2
	$V_{Rd,s,s}$ [kN]	2.9	5.3	8.3	12.1	22.6	35.2	50.7	66.0	80.6
	$M^0_{Rd,s,s}$ [Nm]	3.8	9.0	17.9	31.4	79.8	155.4	268.9	398.7	538.7
8.8	$N_{Rd,s,s}$ [kN]	10.7	19.5	30.9	44.9	83.7	130.7	188.3	244.8	299.2
	$V_{Rd,s,s}$ [kN]	6.4	11.7	18.6	27.0	50.2	78.4	113.0	146.9	179.5
	$M^0_{Rd,s,s}$ [Nm]	9.8	24.0	47.8	83.8	213.1	415.4	718.4	1065.2	1439.4
A4-50	$N_{Rd,s,s}$ [kN]	3.5	6.4	10.1	14.8	27.4	42.8	61.7	80.2	98.1
	$V_{Rd,s,s}$ [kN]	2.5	4.6	7.3	10.6	19.8	30.9	44.5	57.9	70.7
	$M^0_{Rd,s,s}$ [Nm]	3.2	7.9	15.7	27.5	70.0	136.3	235.8	349.7	472.5
A4-70	$N_{Rd,s,s}$ [kN]	7.5	13.7	21.7	31.6	58.8	91.7	132.1	171.8	210.0
	$V_{Rd,s,s}$ [kN]	5.4	9.9	15.6	22.7	42.2	66.0	95.1	123.6	151.0
	$M^0_{Rd,s,s}$ [Nm]	6.9	16.8	33.5	58.8	149.4	291.3	503.7	746.9	1009.2

HALFEN CAST-IN CHANNELS HTA-CE

HALFEN Bolts HS

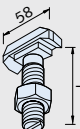
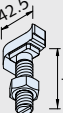
HALFEN Bolts HS								
Suitable for profile	HTA-CE 72/48, 72/49				HTA-CE 55/42, 52/34, 54/33, 50/30P, 49/30			
Bolt	HS 72/48				HS 50/30			
Bolt dimensions								
l [mm]	M20	M24	M27	M30	M10	M12	M16	M20
15								
20								
25								
30					FV4.6 GVs4.6	A4-70 GVs4.6	A4-50 GVs4.6	
35								GVs4.6
40					GVs4.6	A4-70 FV4.6 GVs4.6	A4-50 FV4.6 GVs4.6 GVs8.8	
45						GVs8.8		A4-50 GVs4.6 GVs8.8
50	FV4.6	A4-50 FV4.6			GVs4.6	A4-70 GVs4.6	HCR-50* A4-50 FV4.6 GVs4.6	
55								A4-50 FV4.6 GVs4.6
60	FV8.8					FV4.6 FV8.8* GVs4.6 GVs8.8	A4-50 FV8.8 GVs4.6 GVs8.8	GVs8.8
65								GVs4.6
70								
72								
75	FV4.6 GVs8.8	FV4.6 FV8.8	FV4.6	FV4.6				A4-50 GVs4.6
80							HCR-50* A4-50 A4-50L FV8.8* GVs4.6 GVs8.8	FV4.6* GVs8.8
87						A4-70T	A4-70T	
100	FV4.6 GVs8.8	A4-50 FV4.6 GVs8.8	FV8.8	FV4.6		A4-50 GVs4.6	A4-50T FV4.6 GVs4.6 GVs8.8	A4-50 FV4.6 GVs4.6 GVs8.8
125						GVs4.6	GVs4.6	A4-50 GVs4.6
150	FV4.6	FV4.6		FV4.6		GVs4.6	A4-50 FV4.6 GVs4.6	A4-50 GVs4.6 GVs8.8
200	FV4.6	FV4.6		FV4.6		GVs4.6	GVs4.6	GVs4.6
250								
300							GVs4.6	GVs4.6

L = Left-hand thread T = Partial thread Material types: see page 11 *on request ⓘ Other bolt lengths and materials on request!

HALFEN CAST-IN CHANNELS HTA-CE

HALFEN Bolts HS

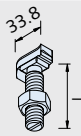
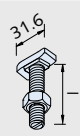
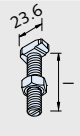
Suitable for profile	HTA-CE 40/22P, 40/25			HTA-CE 38/17			HTA-CE 28/15			
	HS 40/22			HS 38/17			HS 28/15			
Bolt dimensions										
I [mm]	M10	M12	M16	M10	M12	M16	M6	M8	M10	M12
15							GVs4.6	GVs4.6	GVs4.6	
20	GVs4.6	GVs4.6		GVs4.6	GVs4.6		GVs4.6	GVs8.8 GVs4.6	GVs4.6	
25						A4-50	GVs4.6	GVs4.6	A4-70 GVs4.6	
30	A4-70 GVs4.6	A4-50 FV4.6 GVs4.6 GVs8.8	A4-50 GVs4.6	A4-70 FV4.6 GVs4.6	A4-70 FV4.6 GVs4.6	A4-50 GVs4.6	GVs4.6	GVs4.6	A4-70 GVs4.6	HCR-50* A4-70 FV4.6 GVs4.6
35										GVs4.6 GVs4.6
40	A4-70 GVs4.6	A4-50 A4-70 GVs4.6 GVs8.8	GVs4.6	GVs4.6	A4-70 GVs4.6	A4-50 FV4.6 GVs4.6	GVs4.6	GVs4.6	A4-70 FV8.8 GVs4.6	
45		GVs8.8								
50	A4-70 GVs4.6	A4-50 FV4.6 GVs4.6	A4-70 A4-50 A4-50L FV4.6 GVs4.6	FV4.6 GVs4.6	A4-70 A4-50L FV4.6 GVs4.6	A4-50 A4-50L FV4.6 GVs4.6		GVs4.6	HCR-50* A4-70 A4-50L FV4.6 GVs4.6	GVs4.6
55										
60	GVs4.6	FV4.6 FV8.8* GVs4.6 GVs8.8	FV4.6 FV8.8 GVs4.6 GVs8.8	GVs4.6	HCR-50* A4-70 GVs4.6 GVs8.8	A4-50 FV8.8 GVs4.6		GVs4.6	GVs4.6	
65										
70					FV8.8					
72					A4-70T					
75										
80	GVs4.6	A4-50 A4-50 FV4.6 GVs4.6 GVs8.8	A4-50 A4-50L GVs4.6 GVs8.8	GVs4.6	A4-70 A4-50L GVs4.6	A4-50 FV4.6 GVs4.6		GVs4.6	A4-70 GVs4.6	GVs4.6
87										
100	GVs4.6	GVs4.6 GVs8.8	A4-50 FV4.6 GVs4.6	GVs4.6	A4-50 GVs4.6	FV4.6 GVs4.6		GVs4.6	GVs4.6	
125		GVs4.6	GVs4.6		GVs4.6	GVs4.6			GVs4.6	
150		GVs4.6	GVs4.6	GVs4.6	GVs4.6	GVs4.6			GVs4.6	
200		GVs4.6	GVs4.6		GVs4.6	GVs4.6			GVs4.6	
250			GVs4.6							
300			GVs4.6							

L = Left-hand thread T = Partial thread Material types: see page 11 *on request  Other bolt lengths and materials on request!

1 HTA-CE Channels
2 HZA Channels
3 HGB Channels
4 HTU Channels
5 Roof and Wall
6 Curtain Wall
7 Accessories

HALFEN CAST-IN CHANNELS HTA-CE

HALFEN Bolts HS

Torque values HS

Standard

Components are braced against the concrete and anchor channel.

Torque is applied as in the following table and must not be exceeded.

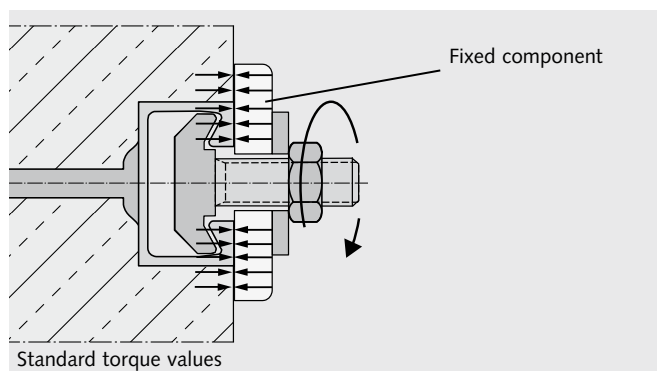

Steel-Steel

Components are braced against the anchor channels using suitable washers.

Torque is applied as in the following table and must not be exceeded.

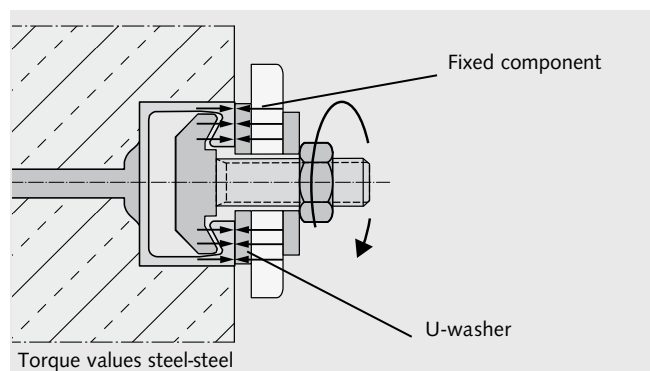

Standard: Recommended torque values T_{inst}		
HTA-CE Profile	HALFEN Bolt HS...M [mm]	Torque value T_{inst} [Nm]
		Steel 4.6; 8.8 Stainless steel Strength class 50 Strength class 70
28/15	6	-
	8	8
	10	13
	12	15
38/17	10	15
	12	25
	16	40
40/22P 40/25	10	15
	12	25
	16	45
49/30 50/30P	10	15
	12	25
	16	60
	20	75
52/34 54/33	10	15
	12	25
	16	60
	20	120
55/42	10	15
	12	25
	16	60
	20	120
72/48 72/49	20	120
	24	200
	27	300
	30	380

Steel-Steel: Recommended torque values T_{inst}					
HTA-CE Profile	HALFEN Bolt HS...M [mm]	Torque value T_{inst} [Nm]			
		Steel 4.6	Steel 8.8	Stainless steel Strength class 50	Stainless steel Strength class 70
28/15	6	3	-	3	-
	8	8	20	8	15
	10	15	40	15	30
	12	25	70	25	50
38/17	10	15	40	15	30
	12	25	70	25	50
	16	65	180	60	130
40/22P 40/25	10	15	40	15	30
	12	25	70	25	50
	16	65	180	60	130
49/30 50/30P	10	15	40	15	30
	12	25	70	25	50
	16	65	180	60	130
	20	130	360	120	250
52/34 54/33	10	15	40	15	30
	12	25	70	25	50
	16	65	180	60	130
	20	130	360	120	250
55/42	10	15	40	15	30
	12	25	70	25	50
	16	65	180	60	130
	20	130	360	120	250
72/48 72/49	20	130	360	120	250
	24	230	620	200	440
	27	340	900	300	650
	30	460	1200	400	850

⚠ Torque values apply only to bolts in delivery condition (unlubricated).

HALFEN CAST-IN CHANNELS HTA-CE

HALFEN Bolts HRS with Nib (Not ETA Approved)

HALFEN Bolts - Type HSR



HALFEN Bolts with nib

- only for hot-rolled profiles: 40/22P, 50/30P, 52/34, 72/48
- only for normal steel: WB and FV
- load capacity in all directions
- load capacity in channel longitudinal direction according to expert report
- identification on bolt tip with **2 notches**

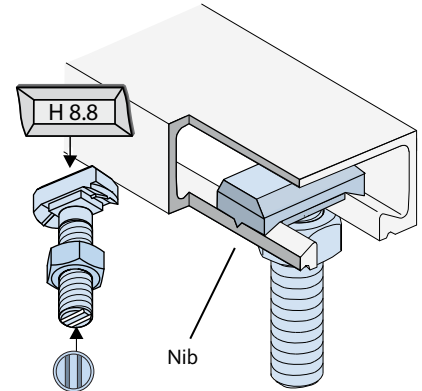

Bolt design values HSR

Available HSR				
Suitable for profile	72/48	52/34, 50/30P		40/22P
Bolt	HSR 72/48	HSR 50/30		HSR 40/22
Bolt dimensions				
l [mm]	M20	M16	M20	M16
40		FV8.8		GVs8.8
45			GVs8.8	
60		GVs8.8	GVs8.8	GVs8.8, FV8.8*
75	FV8.8		GVs8.8	

GVs = Zinc galvanized with special coating
FV = Hot-dip galvanized

* on request

Torque values HSR	
HSR 8.8	Torque values [Nm]
M16	200
M20	400

Load capacity HSR	
Bolt HSR	Grade 8.8 in channel longitudinal direction according to expert report
	F_{Rd} [kN]
40/22 - M16	7.0
50/30 - M16	7.0
50/30 - M20	10.5
72/48 - M20	10.5

HALFEN Bolts HS: Design value; load bearing capacity F_{Rd} [kN]

Design value F_{Rd} [kN] in channel longitudinal direction (per HALFEN HS Bolt)				
	for steel profiles		for profiles in stainless steel	
	Bolt type HS with strength class			
	4.6	8.8 ^①	A4-50	A4-70
Thread Ø				
M6	0.14	0.56	—	—
M8	0.28	0.98	0.28	—
M10	0.42	1.54	0.42	—
M12	0.70	2.24	0.70	—
M16	1.26	4.20	1.26	—
M20	1.96	6.58	1.96	—
M24	2.80	9.52	2.80	—
M27	3.64	12.46	—	—
M30	4.48	15.26	—	—

① Values only applicable with torque moments T_{inst} steel-steel (see table on the right, on page 22)

⚠ Not included in the ETA!

Following combination can be used in supporting structures subjected to loads in channel longitudinal direction:

- hot-rolled, smooth, hot-dip galvanized HALFEN Channels with HALFEN HSR Type Bolts with nib
- serrated HALFEN Channels HZA with serrated HALFEN Bolts HZS, see page 29

See table on the left for the maximum design values for friction load. See page 22 for torque values.

HALFEN CAST-IN CHANNELS HTA-CE

Custom Anchors – Anchor Variations (Not ETA Approved)

ANK-E end anchor; for on-site custom length HALFEN Cast-in channels

Notes for assembling end anchor type ANK-E

- Cut the HALFEN Cast-in channel at the selected point. The cut face must be at a right angle to the longitudinal axis of the channel. The end projection "e" should not be less than 35 mm and not more than 175 (225) mm*.
- Select the correct **ANK-E** End anchor for the HALFEN Cast-in channel profile; see table on the right. Slide the clamping element on to the back of the channel. If necessary, push in the foam filler at the end of the channel.
- Tighten the bolt by applying the required torque. See table (right) for correct torque value.

End anchor selection			
for profile	End anchor	Thread	Torque T_{inst} [Nm]
28/15 - FV	ANK-E1 - FV	M8	10
28/15 - A4	ANK-E1 - A4	M8	10
38/17 - FV	ANK-E2 - FV	M10	20
40/25 - FV			
41/22 - FV ^①			
38/17 - A4	ANK-E2 - A4	M10	20
40/25 - A4			
41/22 - A4 ^①			

① Short HZA 41/22 sections may be used with one end anchor only. Not included in the approval.

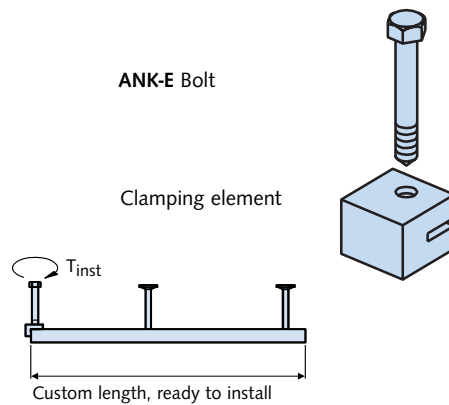

Custom lengths

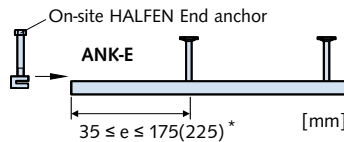

* 175: for 28/15, 38/17
225: for 40/25, 41/22

HALFEN Anchor channels, hot-dip galvanized with stainless steel anchors

Requirements

according to DIN EN 1992-1-1/NA (EC 2 with German National Annex, 2nd edition, 2016, chapter 8.10.1.1) "Ensure at least 20mm concrete between pre-stressed tension strands and galvanized components."

Otherwise there is a risk of hydrogen induced stress corrosion cracking.

Solution

If hot-dip galvanized channels are used together with stainless steel bolt-anchors then the pre-stressed tension-strands are allowed to have contact with the stainless steel bolt anchor.

Types:

Lengths available: up to 6.07 m

Available profiles:

- 50/30P
- 49/30
- 40/25
- 38/17

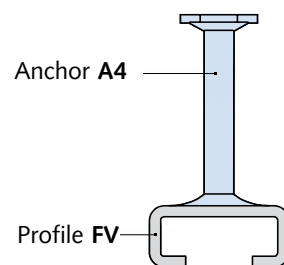
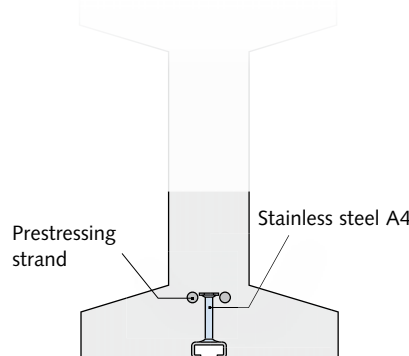
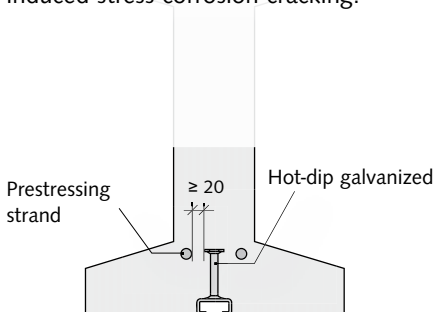

HALFEN CAST-IN CHANNELS HTA-CE

Available Types - HTA-CS / Channel Pairs / Corner Elements

HALFEN Channels HTA-CS - Curved Solution

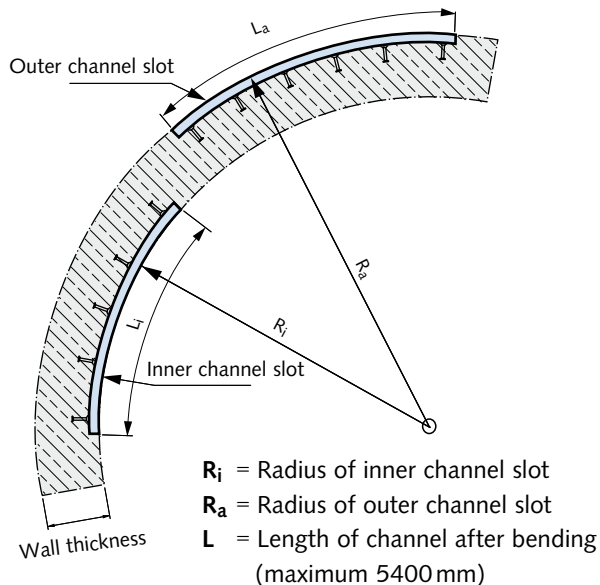

Areas of application:

- tunnel construction
- reinforced concrete tunnels for utilities
- curved walls
- sewage plants

Ordering example:

HALFEN Cast-in channel, curved
 HTA-CS 52/34-Q - A4, $R_i = 4000$ mm, $L = 1050$ mm



Curved HALFEN Cast-in channels in tunnel segments

Smallest radius - all materials

Profile	HTA-CS 72/48	HTA-CS 72/49	HTA-CS 54/33	HZA-CS 53/34	HTA-CS 52/34	HTA-CS 50/30P	HTA-CS 49/30	HTA-CS 40/22P	HTA-CS 40/25	HZA-CS 41/22	HZA-CS 29/20	HZA-CS 38/23	HTA-CS 38/17	HTA-CS 28/15
Inner channel slot: min. R_i	on request	on request	0.80 m	on request	0.75 m	0.80 m	0.80 m	1.80 m	1.60 m	on request	on request	on request	on request	on request
	on request	on request	0.80 m	on request	0.80 m	0.80 m	0.80 m	2.40 m	2.50 m	on request	-	on request	on request	on request
Outer channel slot: min. R_a	4.00 m	on request	4.00 m	on request	3.60 m	2.10 m	3.00 m	2.10 m	4.00 m	on request	on request	on request	on request	on request
	on request	on request	4.00 m	on request	3.60 m	2.10 m	5.70 m	6.00 m	4.00 m	on request	-	on request	on request	on request

hot-dip galvanized stainless steel A4

HALFEN Channel pairs

Material/type:

Channel (Type straight or curved):

FV = Hot-dip galvanized

A4 = Stainless steel

Spacer:

Reinforced concrete B500B or B500B/A NR, $\varnothing 10 - 16$ mm
 Recommended for stainless steel type spacers in: B500B/A NR.

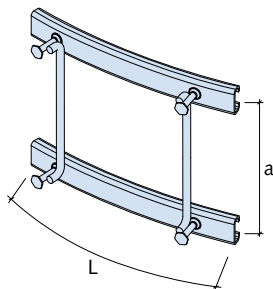

Ordering example:

Type: HALFEN Channel pair HTA-CE 38/17

Dimensions: $L = 350$ mm, $a = 200$ mm

Material: hot-dip galvanized, with filler

Radius: $R_i = \dots$ (for curved type)

HALFEN Corner channel

Material/type:

Channel and anchor:

FV = Hot-dip galvanized

A4 = Stainless steel

Standard type:

$a/b = 125/250$ mm

Other lengths for a and b and other profiles are available on request

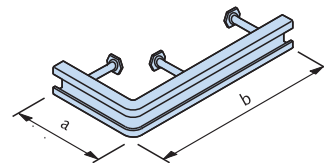

Figure: HTA-CE 38/17 - Corner piece

Area of application:

- fixing for HALFEN Console anchors for supporting masonry renders
- other near edge fixings

HALFEN CAST-IN CHANNELS HTA-CE

Calculation Basics

1

HTA-CE Channels

2

HZA Channels

3

HGB Channels

4

HTU Channels

5

Roof and Wall

6

Curtain Wall

7

Accessories

General

The following information is necessary to verify an anchor channel:

- type of HALFEN Cast-in channel and material
- length of the HALFEN Cast-in channel with number of anchors and spacing
- position of the HALFEN Cast-in channel in the concrete, located by its distance from the lower, upper left and right edges of the component
- thickness of the concrete components
- concrete strength class
- condition of the concrete; cracked or verified as non-cracked
- is there dense reinforcement in the vicinity of the anchor channel
- HALFEN T-head bolt thread size
- bolt positions
- tensile load and shear load of each bolt

Technical support

Engineering services and technical support for your individual projects. Our contact information can be found on page 91 of this catalogue.



Verification method

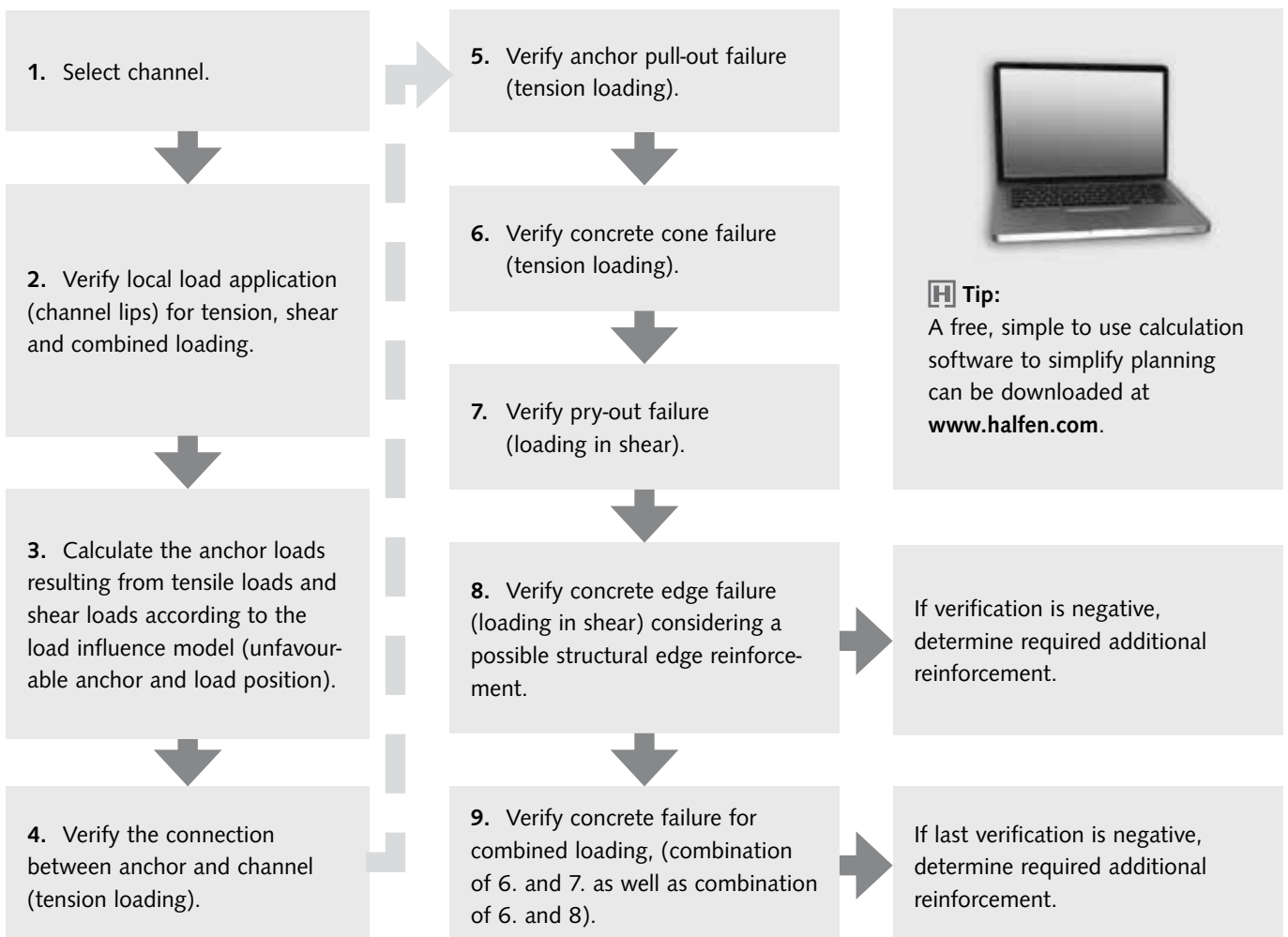

HALFEN CAST-IN CHANNELS HTA-CE

Software

HALFEN Software HTA-CE

The HALFEN calculation program for HALFEN Cast-in channels according to the ETA provides the user with a convenient and very powerful calculation tool.

Verifications

CEN/TS 1992-4 and EOTA TR047 require a wide range of verifications for cast-in channels and the concrete used. These verifications are processed by the user-friendly HALFEN software. In just a few seconds the user is presented with a list of suitable HALFEN Cast-in channels for the relevant load situation.

Boundary conditions

The calculation takes into account all necessary boundary conditions, typical examples being:

- cracked or non-cracked concrete
- the geometry of the concrete components, in particular the distances from the channel to the component edge
- various reinforcement patterns
- consideration of several dimensioning or characteristic loads
- positioning of the loads with a definable adjustment range, and the option of shifting the defined bolt pattern along the complete channel length

- verification of the required HALFEN T-head bolts and if required also for stand-off installations
- engineering consideration of fatigue loads and fire influence

Input

The geometry and loads are entered interactively. Entries are displayed promptly in a 3D graphic. Entries can also be changed directly in the graphic. Click on the load, the measurement or the component line you want to change to make the required modification.

Results

After calculation, the software output provides either the results for a preselected profile, or in the case of automatic selection a list of all suitable profiles. Profiles and T-bolts with in-complete verifications are highlighted in red.



All software can be found under: www.halfen.com > Downloads > Software/CAD



Screenshot 1: The HALFEN HTA-CE Software start screen



Screenshot 2: Input screen, HALFEN HTA-CE Software



Screenshot 3: Interactive 3D-display



Screenshot 4: Results list

HALFEN CAST-IN CHANNELS HTA-CE

Software

HALFEN Software HTA-CE

Visual control

All verifications for the current channel profile are listed in a tree structure. Green check-marks indicate successful verifications. Red check-marks indicate unsatisfactory verifications.

For further visual control a progressbar on the right indicates the status of the verification process. Here too, red bars mean that a load has been exceeded, while green bars symbolize verifications that meet the criteria.

Detailed calculation information (with load positions, section sizes and utilization factors) can also be selected in a tree menu.

After selecting a HALFEN Cast-in channel and suitable bolts, the dimensioning results can be imported into the data list and saved.

Print-outs

Print-outs are possible in a brief and in a verifiable long version. The long version includes all decisive verifications, a diagram of necessary reinforcement and a 2D graphic of the geometry and load.

The latest version of the dimensioning program is available for download on the Internet at www.halfen.com.

System requirements:

- Windows 10, Windows 8, Windows 7,
- Microsoft .NET Framework 4.6



Screenshot 5: Overview of results



Screenshot 6: Print preview

Tender text

HALFEN Channel type HTA-CE 49/30 - A4 - 350 - KF - ANK.A

HALFEN Channel HTA-CE 49/30 with smooth channel lips for adjustable fixing of components,

according to European Technical approval ETA-09/0339, suitable for anchoring in reinforced or non-reinforced standard concrete in a strength class of at least C12/15 and a maximum C90/105 in accordance with EN 206 under quasi-static loading as well as fire exposure.

Type HTA-CE 49/30 - A4 - 350 - KF - ANK.A4

with

$N_{Rk,S,C} = 31 \text{ kN}$ = char. resistance, steel failure (tension), connection channel anchor
A4 = Carbon steel or stainless steel 1.4404 / 1.4571,
350 = Channel length [mm] with 3 anchors,
KF = Foam strip filler,
ANK.A4 = Anchor of stainless steel 1.4404 / 1.4571 / 1.4578,

or equivalent; deliver and install according to the manufacturer's instructions.

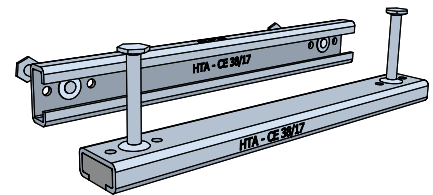

ETA - 09 / 0339
432-CPD-8394-01

HALFEN Cast-in channels HZA

The advantages at a glance

A part from excellent adjustability, HALFEN Cast-in channels save considerable installation time. The result: faster construction and therefore reduced overall costs.

Safe and reliable

- no damage to the main reinforcement
- approved for fire-resistant structural elements
- suitable for installation in concrete pressure and concrete tensile zones
- hot-rolled channels, suitable for dynamic loads
- building authority approved

Quick and economical

- adjustable anchorage
- bolts instead of welding
- maximum efficiency when installing in rows
- cost-effective installation using standard tools
- optimized pre-planning reduces construction time
- large range of channels types for various applications
- user-friendly installation; no noise, dust and vibration

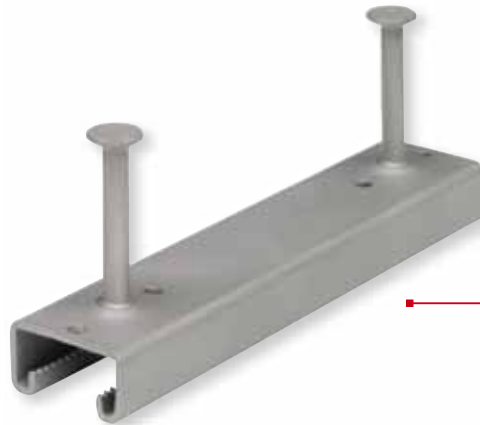

HZA HALFEN Channels
Cold-rolled, serrated

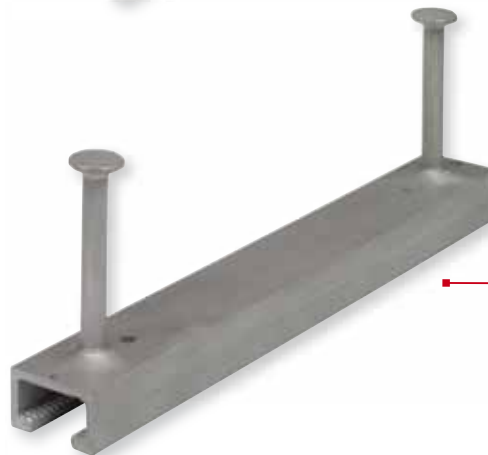

HZA HALFEN Channels DYNAGRIP
Hot-rolled, serrated

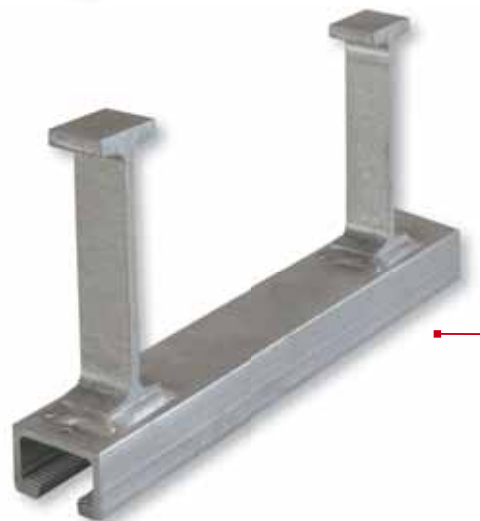
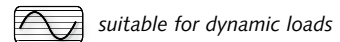

HZA-PS HALFEN Channels
Hot-rolled, serrated

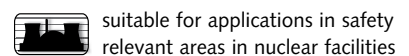
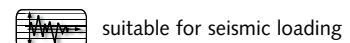
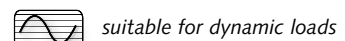

HALFEN Cast-in channels HZA-PS
More Information on HZA-PS is available at:
www.halfen.com > Products > Fixing systems > HZA - DYNAGRIP Cast-In Channels
Or scan the QR-Code and select the current "HZA-PS" catalogue.

HALFEN CAST-IN CHANNELS HZA

Application Examples: Installations with HALFEN Cast-in Channels HZA

CURTAIN WALL

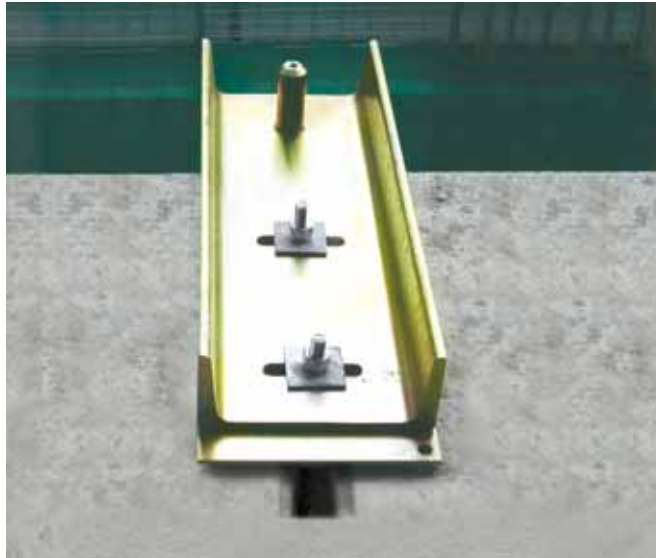

Fixings of a Curtain wall façade, HZA near edge installation

FAÇADES

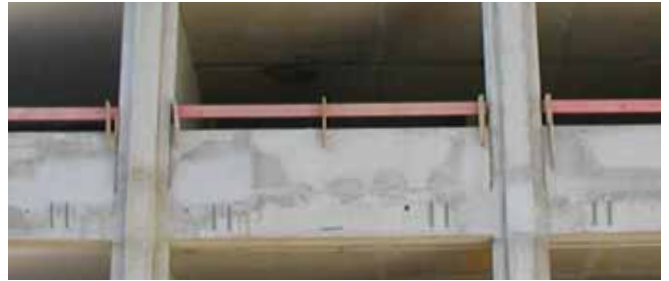

Fixings for emergency access balconies (Vertical installation of HALFEN Channels)

INDUSTRIAL PLANT INSTALLATIONS



Pipe supports on vertical HZA Channels

SKI LIFT



Fixings of the drive unit for a ski lift

LIFTS / ELEVATORS



Fixing for guide rails

INDUSTRIAL BUILDING



Vertical channels in columns to attach further components

1 HTA-CE Channels
2 HZA Channels
3 HGB Channels
4 HTU Channels
5 Roof and Wall
6 Curtain Wall
7 Accessories

HALFEN CAST-IN CHANNELS HZA

Areas of Application / Product Range

Material and area of application				
Area of application	Use only possible if all fixture components are protected by a minimum concrete cover, depending on environmental conditions, as specified in EN 1992-1-1:2011-01.	For interior use only, for example; in residential, office and school buildings, hospital and retail facilities, not suitable for wet rooms.	For use in building components in rooms with normal humidity (including kitchens, bathrooms, laundry rooms in residential buildings).	Building components, corrosion class III, according to EN 1993-1-4, table A.3.
Channel profile	Mill finish	Hot-dip galvanized (thickness $\geq 50 \mu\text{m}$)	Hot-dip galvanized (thickness $\geq 50 \mu\text{m}$)	Stainless steel 1.4404/1.4571
Anchor	Mill finish	Hot-dip galvanized (thickness $\geq 50 \mu\text{m}$)	Hot-dip galvanized (thickness $\geq 50 \mu\text{m}$)	Welded anchor mill finish ②
			Bolt anchor in stainless steel 1.4404/1.4571	Stainless steel 1.4404/1.4462 1.4571/1.4578
Bolts, nuts, washers	No corrosion protection	Zinc galvanized (thickness $\geq 5 \mu\text{m}$) Mechanically galvanized (thickness $\geq 10 \mu\text{m}$)	Hot-dip galvanized ① (thickness $\geq 40 \mu\text{m}$)	Stainless steel A4-50 FA-70 A4-70

① Or zinc galvanized with special coating, thickness > 12 μm .
 ② Only allowed for profiles 38/23, 53/34, 64/44 and 41/22.
 For corrosion protection of the welded anchors a minimum concrete cover c is required: for profile (38/23) 30mm; (41/22) 30mm; (53/34) 40mm; (64/44) 50mm.

Available HZA					
Profile	HZA 64/44 DYNAGRIP	HZA 53/34 DYNAGRIP	HZA 38/23 DYNAGRIP	HZA 29/20 DYNAGRIP	HZA 41/22
Geometry HALFEN Channels HZA	hot-rolled				cold-rolled
Note: observe the installation height h_{inst}					
F_{Rd}	37.8 kN all load directions	30.8 kN all load directions	16.8 kN all load directions	11.2 kN all load directions	7.0 kN all load directions
Material	<input checked="" type="checkbox"/> <input type="checkbox"/>	<input checked="" type="checkbox"/> <input type="checkbox"/>	<input checked="" type="checkbox"/> <input type="checkbox"/>	<input type="checkbox"/>	<input checked="" type="checkbox"/> <input type="checkbox"/>
Bolt	HZS 64/44	HZS 53/34	HZS 38/23	HZS 29/20	HZS 41/22
<input type="checkbox"/> FV = Steel hot-dip galvanized 1.0038/1.0044 <input checked="" type="checkbox"/> A4 =Stainless steel 1.4571/1.4404 Suitable for dynamic loads					

HALFEN CAST-IN CHANNELS HZA

HALFEN HZS Bolts

Available HALFEN HZS Bolts



HALFEN Bolt, serrated

- The serration also ensures a positive load transmission in the longitudinal channel direction. The danger of bolt slippage is minimized.
- The bolt is marked on the shaft end with **2 notches**.

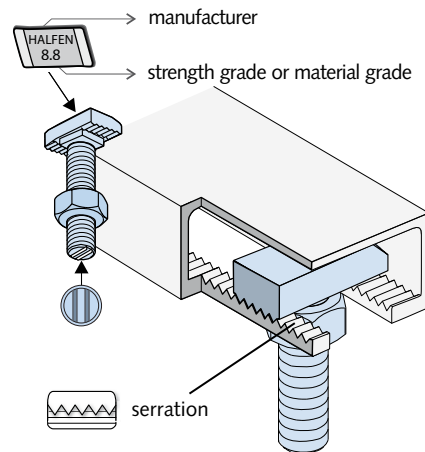

HALFEN Bolts HZS



Suitable for profile	HZA 29/20	HZA 38/23		HZA 53/34		HZA 64/44		HZA 41/22	
Bolt	HZS 29/20	HZS 38/23		HZS 53/34		HZS 64/44		HZS 41/22	
Bolts dimensions									
∅	M12	M12	M16	M16	M20	M20	M24	M12	M16
l [mm]									
30	GVs8.8	GVs8.8							
35								A4-50 FV8.8	
40	GVs8.8	GVs8.8	GVs8.8						
50	FV8.8* GVs8.8	FV8.8* GVs8.8	GVs8.8					A4-50 FV8.8	A4-50 FV8.8
60	GVs8.8	GVs8.8	A4-70 FV8.8 GVs8.8	A4-70 FV8.8* GVs8.8					
65					FV8.8* A4-70 GVs8.8				
80	GVs8.8	GVs8.8	A4-70 FV8.8* GVs8.8	FV8.8*	FV8.8*	A4-70* FV8.8* GVs8.8*	A4-70* GVs8.8*	A4-50	
100		GVs8.8	GVs8.8	A4-70 FV8.8* GVs8.8	A4-70 GVs8.8		FV8.8*		FV8.8
125						A4-70* GVs8.8*			
150			GVs8.8				A4-70* GVs8.8*		

*on request

HALFEN CAST-IN CHANNELS HZA

Calculation

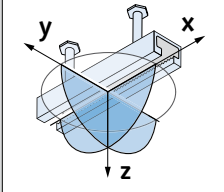
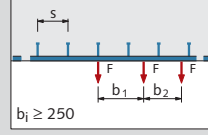
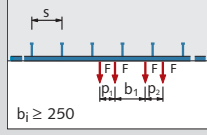

HZA DYNAGRIP Design resistance calculation value F_{Rd}

Design resistance F_{Rd}						
F_{Rd} with simultaneous loading in all directions						
<p>Concrete \geq C20/25 ^①</p> $F_{Ed} = \sqrt{N_{Ed}^2 + V_{xEd}^2 + V_{yEd}^2} \leq F_{Rd}$		single loads		load pairs		
		 F_{Rd} [kN]		 F_{Rd} [kN] ^②		
		$b_i \geq 250$		$p_i \geq 50$	$p_i \geq 100$	$p_i \geq 150$
 Profile HZA DYNAGRIP	64/44	37.8	–	22.4	–	
	53/34	30.8 26.6 (for profiles in A4)	–	19.25	–	
	38/23	16.8	9.4	10.7	12.0	
	29/20	11.2	6.3	7.6	9.0	

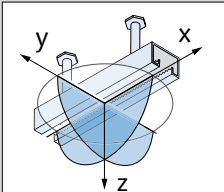
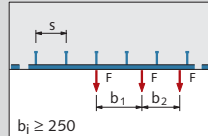
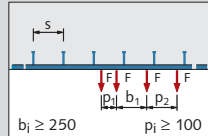

s = Anchor spacing, see page 35

- ① The allowable loads for C20/25 may be reduced by the factor 0.7 when anchoring in concrete, strength class C12/15 and by a factor of 0.67 when anchored in light dense concrete \geq LC 25/28, expanded clay or slate or pumice concrete.
- ② Interim values may be linearly interpolated.

HZA Design resistance calculation value F_{Rd}

Design resistance F_{Rd}					
F_{Rd} with simultaneous loading in all directions					
<p>Concrete \geq C20/25</p> $F_{Ed} = \sqrt{N_{Ed}^2 + V_{xEd}^2 + V_{yEd}^2} \leq F_{Rd}$		single loads		load pairs	
		 F_{Rd} [kN]		 F_{Rd} [kN]	
		$b_i \geq 250$		$b_i \geq 250, p_i \geq 100$	
 Profile HZA	41/22	7.0	4.9		

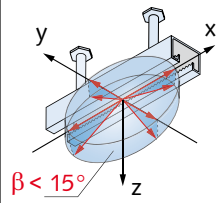
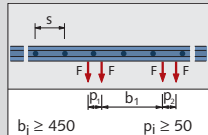
s = Anchor spacing, see page 35

Design resistance F_{Rd}					
F_{Rd} with transverse load					
Paired loads					
<p>Concrete \geq C20/25</p> $F_{Ed} = \sqrt{N_{Ed}^2 + V_{xEd}^2 + V_{yEd}^2} \leq F_{Rd}$		load pairs		Calculation criteria	
		 F_{Rd} [kN]		$\beta = \arccos \left(\frac{V_{xEd}}{\sqrt{N_{Ed}^2 + V_{xEd}^2 + V_{yEd}^2}} \right) < 15^\circ$	
		$b_i \geq 450$	$p_i \geq 50$		
 Profile HZA	41/22	7.0			

s = Anchor spacing, see page 35

HALFEN CAST-IN CHANNELS HZA

Dimensioning

1 Minimum spacing a_r , a_e , a_a , a_f and h

The minimum spacing specified in the table applies to reinforced standard weight concrete of all strength classes $\geq C20/25$.

There are no additional requirements for reinforcement if spacing is increased by 30%.



Minimal spacing HALFEN Channel HZA [mm]

All dimensions in [mm]	Single channel				Paired channels ③			Minimum component size	
	a_r ④	a_a	a_e	a_f	a_{r1}	a_1	a_e	b ①	h ②
HZA 64/44 DYNAGRIP	250	500	225	450	–	–	225	500	$187 + c_{nom}$
HZA 53/34 DYNAGRIP	200	400	175	350	–	–	175	400	$165 + c_{nom}$
HZA 41/22	100 ⑤	150	80	200	100	100	80	200 ⑤	$85 + c$
HZA 38/23 DYNAGRIP	150	300	130	250	225	150	130	300	$99 (154) + c_{nom}$
HZA 29/20 DYNAGRIP	100	200	80	200	140	125	80	200	$87 + c_{nom}$

- ① Minimum component width $b = 2 \times a_r$ applies for single channel configuration. ④ For transverse and angled tensile load the distance from the edge of the unstressed component may be reduced to $a_{r, red.} = 0.5 \times a_r$ or 50 mm if, as in the illustration on page 36, additional reinforcement is used.
- ② Determined by channel height, anchor length and required concrete cover " c_{nom} " as stated in EN 1992-1-1 (EC2), chapter 4.4.1. Channel height h_{inst} in brackets for HZA 38/23 apply only for non-standard profiles with weld-on anchor. ⑤ Additional anchor reinforcement must be used for angled tensile load $\leq 45^\circ$ and transverse tensile stress perpendicular to the edge for spacings of 75 to 100 mm, see page 36.
- ③ Only for centric tensile stress, and for HZA 41/22 also if exposed to stress in channel longitudinal direction.

Torque values for HALFEN Bolts

Torque values [Nm]									
Bolt type Material / Grade	HZS 64/44 8.8	HZS 64/44 A4-70	HZS 53/34 8.8	HZS 53/34 A4-70	HZS 41/22 8.8	HZS 41/22 A4-50	HZS 38/23 8.8	HZS 38/23 A4-70	HZS 29/20 8.8
Thread									
M12	–	–	–	–	50	50	80	–	80
M16	–	–	200	200	120	80	120	120	–
M20	350	350	350	350	–	–	–	–	–
M24	450	450	–	–	–	–	–	–	–



Torque values apply only for bolts in delivery condition (unlubricated).

HALFEN CAST-IN CHANNELS HZA

HALFEN Bolts: Dimensioning / HALFEN HZA Channels: Standard Lengths

HALFEN Bolts HZS – Load capacity and bending moment

Bolts type HZS – Design values F_{Rd} and M_{Rd} ①

 Bolt type	Grade 8.8		Stainless steel A4-50, HCR-50		Stainless steel A4-70	
	F_{Rd} [kN]	Bending moment per bolt ② M_{Rd} [Nm]	F_{Rd} [kN]	Bending moment per bolt ② M_{Rd} [Nm]	F_{Rd} [kN]	Bending moment per bolt ② M_{Rd} [Nm]
29/20 - M12	27.2	61.2	-	-	-	-
38/23 - M12	27.2	61.2	-	-	-	-
38/23 - M16	50.5	155.4	-	-	33.0	116.6
41/22 - M12	27.2	61.2	13.0	21.4	-	-
41/22 - M16	50.5	155.4	24.2	54.3	-	-
53/34 - M16	50.5	155.4	-	-	33.0	116.6
53/34 - M20	79.0	303.0	-	-	51.5	227.2
64/44 - M20	79.0	303.0	-	-	51.5	227.2
64/44 - M24	113.7	524.0	-	-	54.3	183.4

① Observe profile load bearing capacity! If the load bearing capacity of the bolt and the HALFEN Cast-in channel differ; use the smaller of both values.

② Bending moment in the profile or concrete edge; see note below if bending with additional centric or diagonal tensile stress occurs.

Variable bending stress:

For façades renders subjected to variable stress conditions (e.g. due to temperature change), the alternating stress amplitude must not exceed a value of $\sigma_A = \pm 50 \text{ N/mm}^2$ ($\gamma=1.0$) with a mean value of σ_M (relative to the stressed cross section of the bolt).

$$N_{Ed} \leq F_{Rd} \times (1 - M_{Ed} / M_{Rd})$$

F_{Rd} = Bolt design load capacity

M_{Rd} = Design value of possible bending moment

N_{Ed} = Design value of present tensile load

M_{Ed} = Design value of present bending moment

Note:

Combine stress values if bending occurs with additional centric or diagonal tensile stress.

HALFEN HZA Channels – Standard lengths and Anchor positions

Standard lengths – Project related orders

HZA 38/23, 41/22, 53/34, 64/44

Length [mm] / Number of anchors

1050/5	1300/6	1550/7	1800/8
2050/9	2300/10	2550/11	2800/12
3030/13	3300/14	3550/15	3800/16
4050/17	4300/18	4550/19	4800/20
5050/21	5300/22	5550/23	5800/24

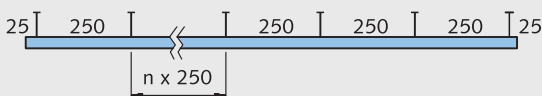

Standard lengths – Project related orders

HZA 29/20

Length [mm] / Number of anchors

1250/7	1450/8	1650/9	1850/10
2050/11	2250/12	2450/13	2650/14
2850/15	3030/16	3250/17	3450/18
3650/19	3850/20	4050/21	4250/22
4450/23	4650/24	4850/25	5050/26
5250/27	5450/28	5650/29	5850/30

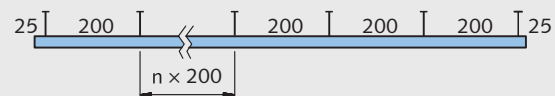

See HALFEN Price list for standard product range (short channels etc.)

HALFENSCHIENEN HZA

Dimensioning

Reduced edge distance $a_{r,}$ with full central tensile stress

Section A - A
Dimensions in [mm]

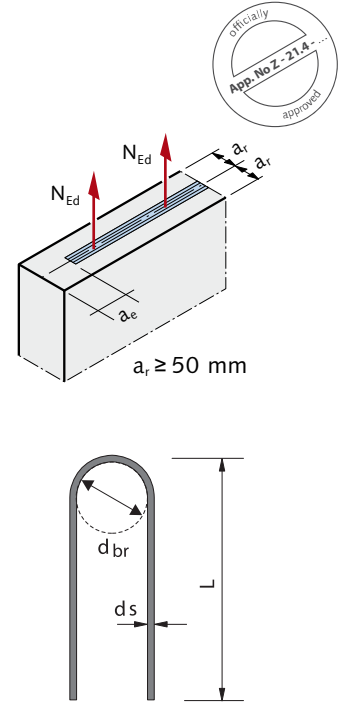
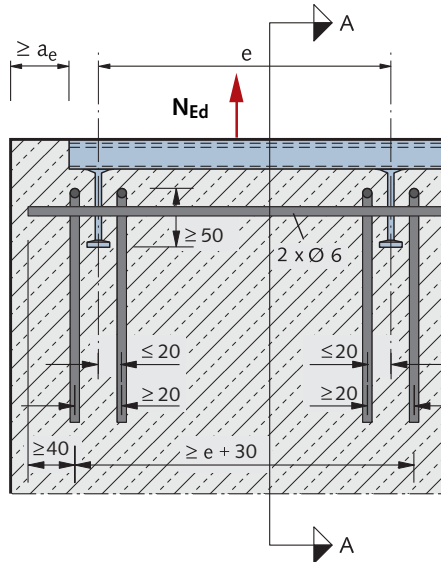
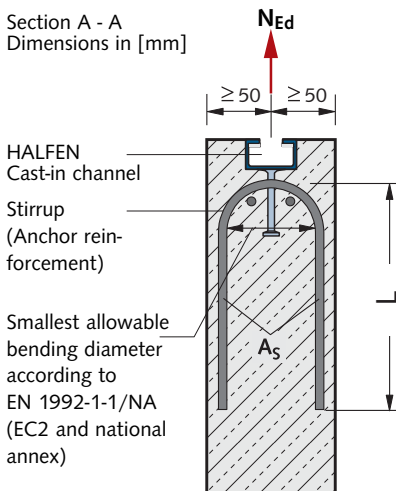

Figure 1: additional reinforcement

Preconditions for reducing the edge distance to 50 mm

Where minimum structural spacing cannot be maintained when installing HALFEN Channels, HZA 41/22, 29/20 and 38/23, for example, in thin façade panels, the distance to the edge a_r

may be reduced to 50 mm, if additional anchor reinforcement as shown in figure 1 is used for the anchor loads and tensile splitting.

Required reinforcement cross section

A_s [cm²] stirrup rebar:

$$\text{req. } A_s = \frac{F_{Rd} \text{ [kN]}}{4 \times \sigma_{Rd} \text{ [kN/cm}^2\text{]}} = \frac{F_{Rd}}{44.8} \text{ cm}^2$$

Steel stress

$\sigma_{Rd} = (1.4 \times \sigma_s) = 11.2 \text{ kN/cm}^2$
with $\sigma_s = 8 \text{ kN/cm}^2$ as in the approval.
Approval no. Z-21.4-145 (HZA),
Z-21.4-1691 (HZA DYNAGRIP)
for this example.

Required stirrup dimensions			
Profiles	stirrup dimensions [mm]		
	L	ds	d _{br}
HZA 29/20, 41/22	250	6	24
HZA 38/23	250	8	32

Additional reinforcement for HZA 41/22 with edge distance ≥ 75 and < 100 mm

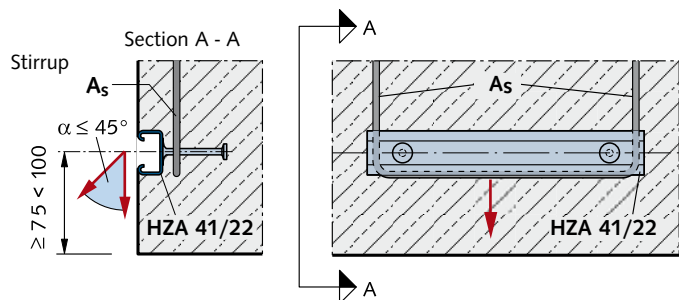
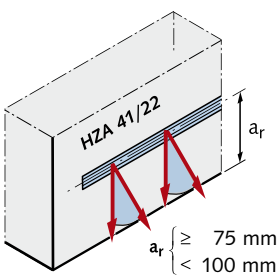

Figure 2: Additional reinforcement placement

$$\text{req. } A_s = \frac{F_{Rd} \text{ [kN]}}{\sigma_{Rd} \text{ [kN/cm}^2\text{]}} = \frac{F_{Rd}}{11.2} \text{ cm}^2$$

$\sigma_{Rd} \rightarrow$ see above

Additional reinforcement for edge distance for HALFEN Channels HZA 41/22 from $75 \text{ mm} \leq a_r < 100 \text{ mm}$ and loads perpendicular to the edge (figure 2).

HALFEN CAST-IN CHANNELS HZA AND HTA

Dynamic Loading

Dynamic loads for hot-rolled HALFEN Cast-in channels

The stress amplitudes shown below apply only for anchor channels in the stated material and configurations. Only the matching screws, shown on the right in the table, may be used.

Profile anchor configuration ①	Material	allow. stress amplitude $\Delta F = F_o - F_u$ [kN] for tensile stress	approved bolts
29/20-B6, 29/20-Q	1.0044	2.0	M12
38/23-B6, 38/23-Q	1.0044	3.0	M16
	1.4404/1.4571	2.4	
40/22-B6, 40/22-Q	1.0038	2.0	M16
50/30-B6, 50/30-Q		2.4	M16, 20
52/34-Q		7.0	M20
53/34-B6, 53/34-Q	1.0044	6.0 / (12 ^②)	M16, 20
	1.4404/1.4571	4.0 / (10 ^②)	
55/42-Q	1.0038	8.0	M20
64/44-Q/L ②	1.0044	15.0 ^②	M20, 24
	1.4404/1.4571	11.0 ^②	
72/48-Q	1.0038	7.0	M24, 27, 30

- ① Anchor configurations:
B6: with bolt anchor
Q: with I-anchor welded transverse to the channel
Also refer to approvals Z-21.4-34 and Z-21.4-1691
- ② values apply for anchor channels with weld-on anchors type I 140/7,1 with anchor/weld joint position Q/L (cross/lengthwise)

Ordering example for dynamic loads:

HZA 38/23 - FV - 350
(standard order includes bolt anchor B6) or:
HTA 52/34 - Q - FV - 550

Example:

HZA 38/23 profile - FV (standard, hot-dip galvanized),
channel length = 250mm

max. load:

$$12 \text{ kN} \quad (\text{allow. } F = \frac{16.8 \text{ kN} \rightarrow \text{page 33}}{1.4}) = \frac{F_{Rd}}{1.4}$$

including dynamic load:

$$3 \text{ kN} \quad (\text{stress amplitude } \Delta F)$$

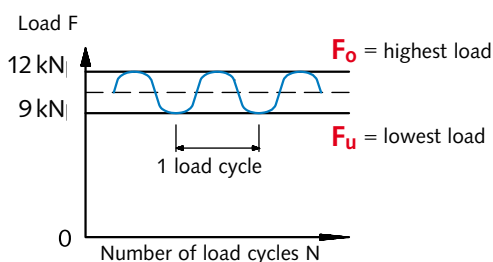

If load cycles are less than $N = 2 \times 10^6$, the amplitude for the HTA 40/22 and HTA 50/30 profiles can be found in the diagram below.



Defining amplitude

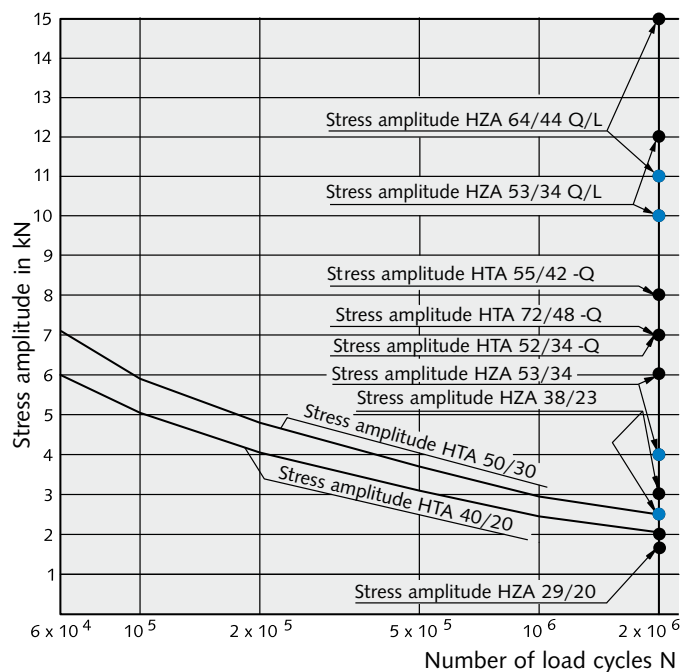

Material: steel

Material: A4

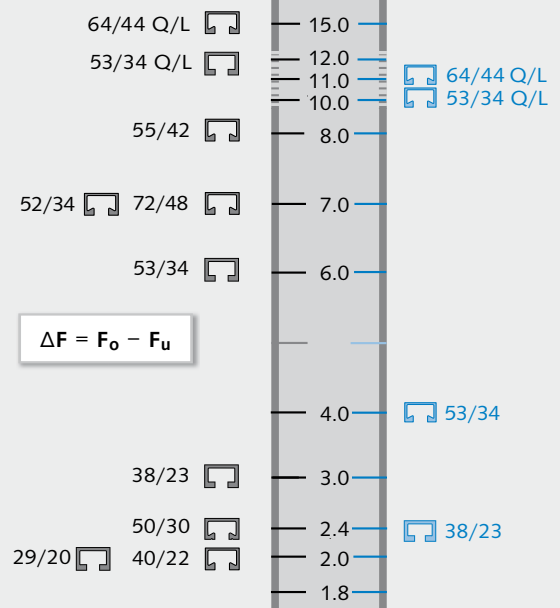

$$\Delta F = F_o - F_u$$

HGB Handrail Connections

The advantages at a glance

Construction specialists consider the HALFEN HGB Handrail connections to be particularly well suited for fastening banisters to the thin front faces of balcony slabs.

Fast and cost-effective

- adjustable anchorage
- can also be used in slabs as thin as $h \geq 100$ mm
- installed with bolts instead of welding or drilling
- pre-planning reduces on-site construction time
- all attached components remain fully adjustable or are easily replaced as required

Safe and reliable

- statically verified installation
- no damage to visible surfaces of concrete slabs
- also suitable to secure mandatory safety rails during construction (Refer to: DIN EN 795 "Guard rails")
- use with HALFEN high-strength bolts to ensure a secure and statically sound connection of banister components



HALFEN HGB Handrail connections
Profile HGB E-54/33-A4



HALFEN HGB Handrail connections
Profile HGB E-49/30-A4



HALFEN HGB Handrail connections
Profile HGB E-40/25-A4



HALFEN HGB Handrail connections
Profile HGB E-38/17-A4



HALFEN HGB HANDRAIL CONNECTIONS

Application Examples

SAFETY BARRIERS IN STADIUMS



①-④: Safety rail installation, multi purpose arena in Berlin



Fixing of safety rails, Rheinenergiestadion Cologne



Fixing of safety rails, Rheinenergiestadion Cologne

RAILINGS



Used to secure safety rails during the construction phase



Cast-in HGB Channel, residential building

1

HTA-CE Channels

2

HZA Channels

3

HGB Channels

4

HTU Channels

5

Roof and Wall

6

Curtain Wall

7

Accessories

HALFEN HGB HANDRAIL CONNECTIONS

General

1 Regulatory requirements

Balconies are part of the structural system. "They must be designed, constructed, maintained and modified in such a fashion that public order and safety, especially to health or life, is not endangered". (MBO = Musterbauordnung / model building code 07 and construction guidelines).

Technical guidelines issued by public notice as technical building regulations must be observed.*

Technical rules provide information on load parameters, calculation, dimensioning of structural products,

construction types, structural layouts etc. A requirement of regional building codes refers to structural stability: "All structures must, as a whole and in its individual components, be structurally self-supporting". This stability must be statically verifiable based on current technical standards.

A further building regulation addresses traffic loads, for example: Balconies and loggias must be fitted with safety rails to prevent falls when they border on to an area with a drop of more than one metre. For a drop height up

to 12 m the minimum banister height is 0.90 m measured from the upper surface of the finished floor surface or accessible ledge. For drop heights greater than 12 m the banister height must be at least 1.10 m. For exceptions see the German Federal building regulations / Deutsche LandesBauOrdnung.

Other regulations, not covered here, address the design, dimensioning, required spacings in the guard rail design, fire protection, thermal/sound insulation and rainwater drainage.

*through the highest construction supervision authorities of the German Federal States

Regulations, standards and directives (to be observed when designing safety rails)

Regional Building Codes



Individual regional states have their own building codes and regulations. All current technical regulations require proof of structural safety and integrity. A static calculation or a building authority certificate is required when designing and dimensioning the fixings for guard rails.

VOB – Part B, § 4, execution of construction:



§ 4.2 (1) It is the contractor's responsibility to provide the static documentation in accordance with the contract. He has to observe the recognized standards of practice as well as with the provisions of the law and regulatory directives. VOB (Vergabe- und Vertragsordnung für Bauleistungen / Tender and Contract Regulations for the German building industry) Part B, § 4.3, requires the contractor to report to the customer, in writing, any obvious design flaws, which he as the expert must be able to recognize. He alone is responsible for any resulting defect and consequential expenses. If he has satisfied his reporting obligation, the responsibility for the defect passes to the customer (defect example: banister attachment mounted in too thin a concrete slab).

BVM Directive

Directive on metal banisters / balustrades, published by the: BVM Berufsverband Metall / Federal Association of German Metalworkers.

Other applicable regulations and standards (Extract):



- Accident Prevention Regulation "General Provisions" (VGB 1)
 - Industrial Safety Regulations
 - ETB – Directive "Fall Prevention Installations", 1985 Issue
 - Stainless Steels, EC3 part 1–4
- DIN EN 1992-1-1 (EC2): Design and construction of concrete support structures; with National Annex (NA)
- DIN EN 1991 (EC1): General effects on load structures; with National Annex (NA)
- DIN EN 1993 (EC3): design and construction of steel structures; with National Annex (NA)

HALFEN HGB HANDRAIL CONNECTIONS

Materials / Corrosion Protection

Stainless Steel A4:

Chromium is the most important alloy element in stainless steel. A specific chromium concentration ensures the generation of a passive layer on the surface of the steel that protects the base material against corrosion. This explains the high corrosion resistance of stainless steel.



"Anchor channels in stainless steel may be used outdoors – also in an industrial and coastal environment, but may not be directly exposed to salt water".

See guidelines for "Metal banisters and balustrades" issued by the BVM (Bundesverband der Metallverarbeiter) (German Association of Metalworkers).

HALFEN Cast-in channels, stainless steel

Description	Stainless steel		
	Materials	Standard	Corrosion resistance class according to EN 1993-1-4, table A.3
Channel profile	1.4404 or 1.4571	DIN EN 10 088	III
Ribbed-head anchor	Reinforcing steel B500B Reinforcing steel BSt 500 NR	DIN 488	

HALFEN Bolts, stainless steel

Description	Stainless steel		
	Materials	Standard	Corrosion resistance class according to EN 1993-1-4, table A.3
Bolt	A4-70: 1.4404 or 1.4571	DIN EN 3506-1 and DIN EN 10 088	III
Hexagonal nut	A4-70: 1.4404 or 1.4571	DIN EN 3506-2 and DIN EN 10 088	III
Washer	1.4404 or 1.4571	DIN EN 10 088	III

- WB = Steel mill finish
- A4 = Stainless steel

Galvanized:

Dipped in a galvanizing bath at a temperature of approximately 460°C, a method used primarily for open-profile channels.

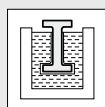

Galvanized material for interior, dry rooms, for instance when installing staircase banisters in residential buildings, schools or commercial retail stores.

Available on request

Identification of HALFEN HGB Cast-in channels

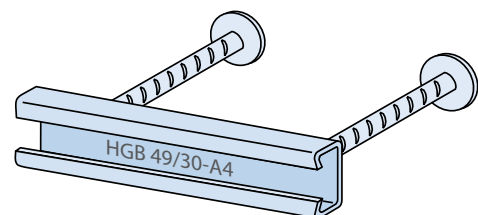
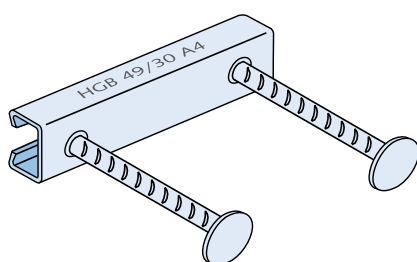

Product identification

- on channel side
- additionally inside the profile

HALFEN HGB HANDRAIL CONNECTIONS

Installation / Assembly

1

HTA-CE Channels

2

HZA Channels

3

HGB Channels

4

HTU Channels

5

Roof and Wall

6

Curtain Wall

7

Accessories

1 Nail the HALFEN Cast-in channel to the formwork

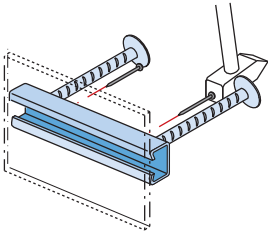

Where possible, use stainless steel nails to avoid corrosion.
After striking the formwork remove the foam filler from the HALFEN Cast-in channels.



Nail the HALFEN Cast-in channel to the formwork

2 Installation and adjustment of balustrades

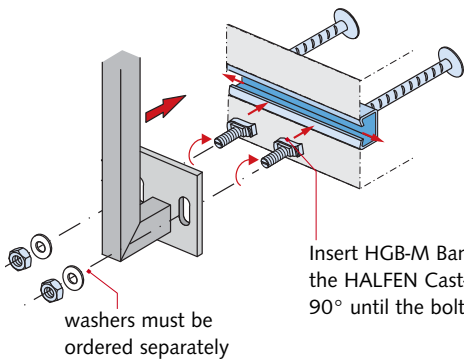

Insert HGB-M Banister bolts into the HALFEN Cast-in channel (turn 90° until the bolt locks into place).

washers must be ordered separately

3 Tighten the bolts

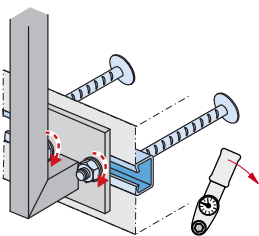

Tighten the nuts using a torque wrench. See table on the right for torque values

Railing bolts		Torque [Nm]	
Stainless steel Material grade A4-70			
HGB - M 50/30		M16	60
for profile 49/30 and 54/33		M12	25
HGB - M 40/22		M16	45
for profile 40/25		M12	25
HGB - M38/17		M16	40
for profile 38/17		M12	25

Fixing position of the bolts

Short piece

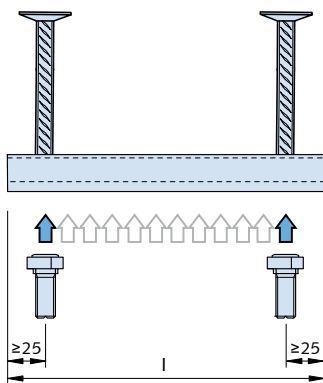

Corner piece (on request)

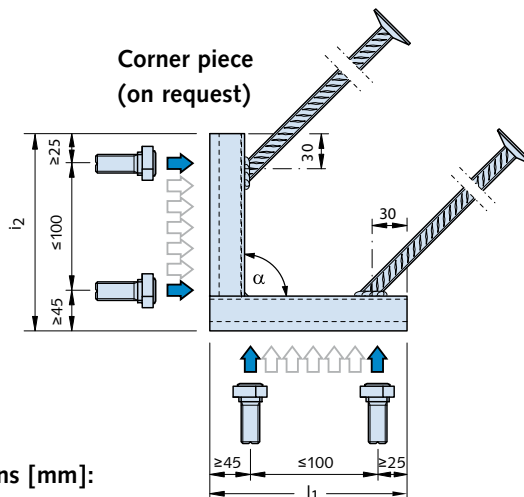

Dimensions [mm]:
 $l_1 = 170$, $l_2 = 170$, $\alpha = 90^\circ$

HALFEN HGB HANDRAIL CONNECTIONS

Product Range

HALFEN HGB Cast-in channels and bolts										
Item description	Dimensions HGB-E [mm]				Dimensions HGB-EE [mm]				HALFEN HGB Bolts	
	l	d _A	h _A	Weight kg/each G	l ₁ / l ₂	d _A	h _A	Weight kg/each G	Type / FK	Dimensions
<p>HGB E - 54/33-A4 B500B (BSt 500 S)</p>	100	14	200	1.071	170/170	14	250	2.262	HGB M-50/30 A4-70	M12×40
	150			1.307						M16×50
	200			1.543						
<p>HGB E - 49/30-A4 B500B (BSt 500 S)</p>	100	12	110	0.704	170/170	14	150	1.501	HGB M-50/30 A4-70	M12×40
	150			0.855						M16×50
	200			1.007						
<p>HGB E - 40/25-A4 B500B (BSt 500 S)</p>	100	10	90	0.611	170/170	14	90	1.042	HGB M-40/22 A4-70	M12×40
	150			0.717						M16×40
	200			0.822						
<p>HGB E - 38/17-A4 B500B/A NR (BSt 500 NR)</p>	100	10	201	0.824	170/170	12	201	1.214	HGB M-38/17 A4-70	M12×40
	150			0.911						M16×40
	200			0.999						

■ **A4** = Stainless steel
1.4571/1.4404

Alternative for interiors
(on request):

■ **FV** = Steel hot-dip galvanized
1.0038/1.0044



In addition to the cold-rolled profiles listed in the table above the following hot-rolled profiles are also generally available:

- 40/22
- 50/30
- 52/34

Ordering and materials

Ordering example HGB channel:

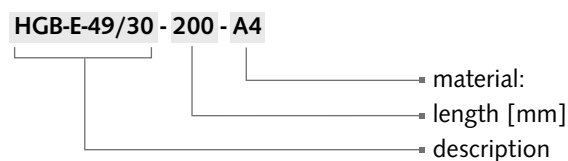

Ordering example banister bolt:

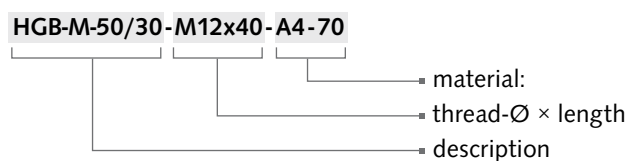

1 HTA-CE Channels
2 HZA Channels
3 HGB Channels
4 HTU Channels
5 Roof and Wall
6 Curtain Wall
7 Accessories

HALFEN HGB HANDRAIL CONNECTIONS

Dimensioning Fundamentals

1 HTA-CE Channels
2 HZA Channels
3 HGB Channels
4 HTU Channels
5 Roof and Wall
6 Curtain Wall
7 Accessories

Banister height

The minimum height h_b of a banister is 0.90m from the top surface of the finished floor or accessible ledge to the upper edge of the rail. For drop heights of more than 12.0m the banister must be at least 1.10m in height. (Exceptions; as specified in regional building codes)

It would be advisable to have one uniform minimum height of 1.00 m as has already been mandated in the commercial sector and in a number of European countries.

Balcony slab

Anchor channels or dowel installations require concrete of at least C 20/25 grade. If the concrete grade is less than C 20/25 grade or it is unknown a case-by-case decision must be made.

The thickness of the balcony slab must be at least $h = 100 - 150$ mm when the HGB is mounted in the slab edge (depends on channel profile and according to German HGB approval). Other types of installation and systems require a thicker slab. All weather-exposed concrete-embedded installations (e.g. for balconies) must be made of stainless steel.

Spacings

Any structural design must take all basic requirements for railings and banisters into account. As a general rule, all railings and banisters must be designed so that personal injury is ruled out, for instance with correct spacing of rails, lattice bars or panels. They should also be designed so as not to entice but instead to discourage anyone from climbing over. The specific requirements for guard rail design are determined by the intended use (residential, public, commercial) and the drop height involved. Also observe the building codes of each country or region, the ETB guidelines "Fall Protection Components" and DIN 18065 (Stairs in Buildings – definition, rules, key measurements) and guard rail regulation applicable at the construction site. In Germany these are the "Geländer-Richtlinie 2012 (BVM Berufsverband Metall)", Federal Association of German Metalworkers.

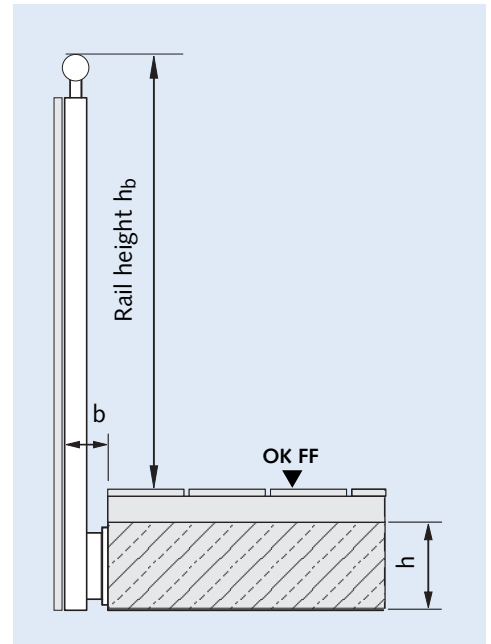

b = clear distance between the back of the veneer and the front face of the balcony slab or gutter / kick plate

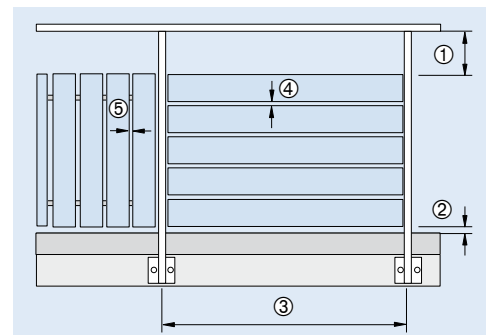

- ① clear distance between bottom edge of hand rail and top edge of facing / lower structure
- ② clear distance between the top edge of the finished floor and the bottom edge of the facing / lower structure
- ③ axis spacing between posts
- ④ clear distance between horizontal facings
- ⑤ clear distance between vertical facings

HALFEN HGB HANDRAIL CONNECTIONS

Dimensioning

Dimensions

The forces acting on the banister must be transferred into the main building structure. It is necessary to verify that the forces

- a) are wholly supported by the banister and
- b) can be transferred via the connecting elements into the balcony slab.

$$N_{Ed} = \frac{M_{Ed}}{(e - 0.41 \cdot x)} + H_{Ed}$$

N_{Ed} = tensile force on the anchor

e = distance between channel axis and outer edge of the banister base plate

x = maximum concrete pressure zone level according to appendix 8, table 8a and 8b

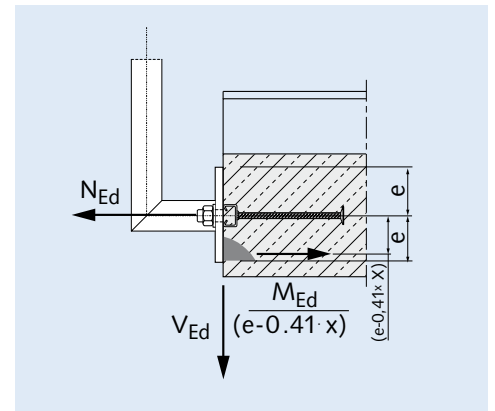

Banister heights

Drop height	Minimum height of rails (recommended)	Note
Less than 12 m	90 cm (100 cm)	Relevant regional building regulations and if necessary other regulations e.g. for civil constructions must be observed.
Greater than 12 m	110 cm	

Calculation

1. Banister load h according to DIN EN 1991-1-1/NA Table 6.12 DE

"Calculation must assume 100% traffic load in drop direction and 50% of traffic load (but not less than 0.5 kN/m) in the opposite direction."



for example: residential buildings and communal areas with low foot traffic	$q_k = 0.5 \text{ kN/m}$
for example: rooms for mass assembly, commercial sales spaces, corridors	$q_k = 1.0 \text{ kN/m}$
for example: areas with large gatherings of people, factories, workshops	$q_k = 2.0 \text{ kN/m}$

2. Vertical loads v according to BVM guidelines

Load assumptions to calculate vertical loads are according to the BVM guidelines for guard rails/banisters.



from dead weight of structure including any renders	$v_1 = 0.40 \text{ kN/m}$
from window box	$v_2 = 0.35 \text{ kN/m}$
support capacity	$v_3 = 0.15 \text{ kN/m}$

3. Wind loads F_w according to DIN EN 1991-1-4 and DIN EN 1991-1-4/NA



Velocity force q in kN/m^2 and total wind pressure F_w are calculated according to DIN EN 1991-1-4 with DIN EN 1991-1-4/NA.
--

HALFEN HGB HANDRAIL CONNECTIONS

Dimensioning

Extract from HGB approval Z-21.4-1912, page 6

3.2.2 Actions and required verifications

The actions H_{Ed} , V_{Ed} , M_{Ed} and N_{Ed} have to be determined according to the calculation basics as in appendix 7. The ratio in the design calculation between horizontal action and bending moment is limited to:

$$\frac{H_{Ed}}{M_{Ed}} \leq 1.5 [1/m] \quad H_{Ed} \text{ [kN]}; M_{Ed} \text{ in [kNm]}$$

It has to be verified that the design action value E_d does not exceed the design resistance value R_d :

$$E_d \leq R_d \quad \text{see table 3.1 and 3.2 below}$$

E_d = Design action value (N_{Ed} , V_{Ed} , M_{Ed})
 R_d = Design resistance value (N_{Rd} , V_{Rd} , M_{Rd})

For a standard case the following equation for the design action value applies (permanent load and variable load acting in the same direction):

$$E_d = \gamma_G \cdot G_k + \gamma_Q \cdot Q_k$$

G_k ; Q_k = characteristic value of permanent load or variable load according to recognized standards for load assumptions
 γ_G ; γ_Q = partial safety factors for permanent and variable action

Extract from HGB approval Z-21.4-1912, page 7

Table 3.1 Required verifications for tensile loads

Steel failure	$N_{Ed} \leq N_{Rd,s}$ $\leq N_{Rd,s,s} \text{ (for single-bolt fixing)}$ $\leq 2 N_{Rd,s,s} \text{ (for two-bolt fixing)}$
Pull out failure	
Concrete failure with anchor reinforcement	
Spalling	

Table 3.2 Required verifications for shear loads

Steel failure	$V_{Ed} \leq V_{Rd,s}$ $\leq V_{Rd,s,s} \text{ (for single-bolt fixing)}$ $\leq 2 V_{Rd,s,s} \text{ (for two-bolts fixing)}$
Concrete failure with anchor reinforcement	
Concrete edge failure with anchor reinforcement	$V_{Ed} \leq V_{Rd,c}$
	$M_{Ed} \leq M_{Rd,c}$

With combined loads the following interactions must be verified:

- $$\max. (N_{Ed} / N_{Rd,s})^2 + \max. (V_{Ed} / V_{Rd,s})^2 \leq 1.0$$

or

$$\max. (N_{Ed} / N_{Rd,s}) + \max. (V_{Ed} / V_{Rd,s}) \leq 1.2$$
- $$M_{Ed} / M_{Rd,c} + 1.5 V_{Ed} / V_{Rd,c} \leq 1.5 \quad \text{for } 0.333 \leq V_{Ed} / V_{Rd,c} \leq 1.0$$

HALFEN HGB HANDRAIL CONNECTIONS

Dimensioning

Extract from HGB-approval Z-21.4-1912, appendix 6

Table 6: Installation and anchor parameters

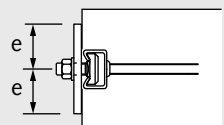
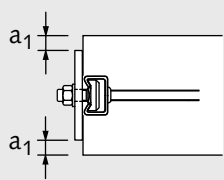
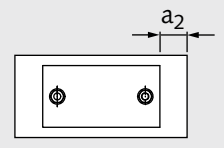
Description	Illustration	Anchor channels profiles			
		38/17	40/22 40/25	50/30 49/30	52/34 54/33
A) Profile shape and bolt positioning					
Minimum channel length required for a two-bolt fixing [mm]	appendix 2	150	150	150	150
Minimum bolt distance p [mm]	see next page	80	80	80 (100) ①	80 (100) ①
B) Building element dimensions and anchor position in the element					
Minimum thickness of concrete element h [mm]	appendix 8	100	120	140	150
Minimum edge distance c_1 [mm] (channel axis to the upper and the lower edge of the concrete element)	appendix 8	50	60	70	75
Minimum distance a_e [mm] to edge of concrete element (from end of channel)	see next page	40	45	50	50
C) Size and position of anchor plate					
Minimum distance e [mm] from channel axis to the upper and the lower edge of the anchor plate		30	30	35	37.5
Minimum distance a_1 [mm] from the upper and lower edge of the anchor plate to the upper and lower edge of the concrete component ②		10	10	10	10
Minimum distance a_2 [mm] from the outer edge of the anchor plate to the edge of the concrete component		40	45	45	45

① The values in brackets apply when using M20 bolts

② In components with a weather groove, the bottom of the groove is regarded as the concrete element edge

HALFEN HGB HANDRAIL CONNECTIONS

Dimensioning

Extract; HGB approval Z-21.4-1912, appendix 6

Table 7: Size and position of required minimum reinforcement

Description	Anchor channels			
	38/17	40/22 40/25	50/30 49/30	52/34 54/33
Stirrup / Quantity	3 Ø 8 $l_b = 200 \text{ mm}$	3 Ø 8 $l_b = 250 \text{ mm}$	3 Ø 10 $l_b = 300 \text{ mm}$	3 Ø 12 $l_b = 400 \text{ mm}$
Edge rebar, top and bottom [mm]	Ø 8	Ø 8	Ø 10	Ø 12

Required minimum reinforcement:

One stirrup is placed centrally between the channel anchors and one stirrup directly next to each anchor at the channel ends (if positioned near to the edge, between the anchor and component edge).

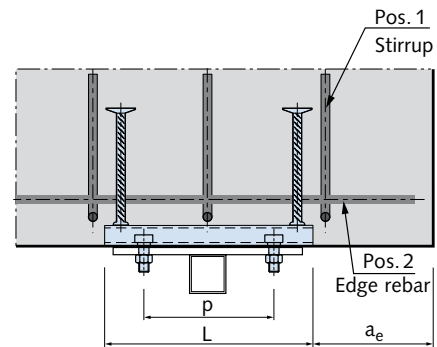

Extract; HGB approval Z-21.4-1912, appendix 8

Table 9: Design resistance for each bolt

Tensile				
Bolts Ø	M12	M16	M20	
$N_{Rd,s,s}$ [kN]	4.6	16.9	31.4	49.0
	8.8	44.9	83.7	130.7
	A4-, HC-50	14.8	27.4	42.8
	A4-70*	31.6	58.8	91.7
Shear				
$V_{Rd,s,s}$ [kN]	4.6	12.1	22.6	35.2
	8.8	27.0	50.2	78.4
	A4-, HC-50	10.6	19.8	30.9
	A4-70*	22.7	42.2	66.0

* Values also apply for all stainless steels of strength class 70 (see also HGB approval, appendix 4)

Design resistance of concrete pressure zone

$$M_{Rd,c} = 0.81 \cdot x \cdot b \cdot \frac{f_{ck}}{\gamma_{Mc}} \cdot (e - 0.41 \cdot x)$$

where:

- x = maximum height; concrete pressure zone (see table 8a and 8b)
- b = width of pressure zone = width of anchor plate b_p
- f_{ck} = characteristic compression strength of concrete in accordance with DIN EN 206-1:2001-07, for concrete strength $\geq C30/37$ only calculate using $f_{ck} = 30 \text{ N/mm}^2$
- e = distance between anchor channel axis and outer edge of the anchor plate (see illustration on page 47, table 6)
- $\gamma_{Mc} = 1.5$ (partial safety factor)

HALFEN HGB HANDRAIL CONNECTIONS

Dimensioning

Extract, HGB-approval Z-21.4-1912, appendix 8

Table 8a: Design resistance of the channel using single-bolt fixing

Channel type		38/17	40/25	40/22	49/30	50/30	54/33	52/34
Minimum thickness of component h [mm]		100	120		140		150	
Steel failure (single-bolt fixing)								
Tension	$N_{Rd,s}$ [kN]	10.0	11.1		17.2		30.6	
Shear	$V_{Rd,s}$ [kN]	10.0	11.1	14.4	17.2	23.4	30.6	39.7
Concrete failure (single-bolt fixing)								
$V_{Rd,c}$ [kN]		6.7	9.0		11.7		12.7	
Maximum height of concrete pressure zone x		$0.25 \cdot e^{①}$	$0.25 \cdot e^{①}$		$0.30 \cdot e^{①}$		$0.40 \cdot e^{①}$	

Table 8b: Design resistance of the channel using a two-bolt fixing

Profile		38/17	40/25	40/22	49/30	50/30	54/33	52/34
Minimum thickness of component h [mm]		100	120		140		150	
Steel failure (two-bolt fixing)								
Tension	$N_{Rd,s}$ [kN]	15.0	16.7		25.8		45.8	
Shear	$V_{Rd,s}$ [kN]	15.0	16.7	21.6	25.8	35.1	45.8	59.6
Concrete failure (two-bolt fixing)								
$V_{Rd,c}$ [kN]		6.7	9.0		11.7		12.7	
Maximum height of concrete pressure zone x		$0.25 \cdot e^{①}$	$0.25 \cdot e^{①}$		$0.30 \cdot e^{①}$		$0.40 \cdot e^{①}$	

① e = distance between anchor channel axis and outer edges of the anchor plate. For asymmetrical anchor plates the smallest distance to the outer edge of the anchor plate is used for calculation.

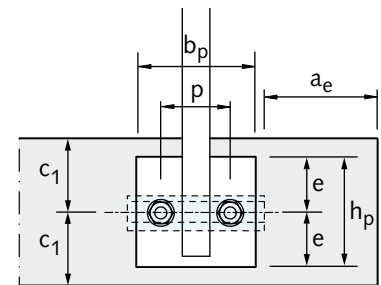
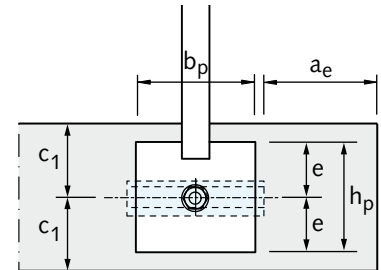

Dimensioning example HALFEN HGB Guard rail fittings

- M_{Ed} = used to calculate applicable moment relative to the channel axis
- e_{v1}, e_{v2}, e_{v3} = distance of the vertical loads to the front edge of the channel
- e_{h1}, e_{Fw} = distance of the horizontal loads to the front edge of the channel
- H_{Ed} = used to calculate the applicable horizontal effect
- V_{Ed} = used to calculate the applicable vertical effect
- h, F_w = horizontal load effects
- v_1, v_2, v_3 = vertical load effects
- b_p, h_p = anchor plate width and height

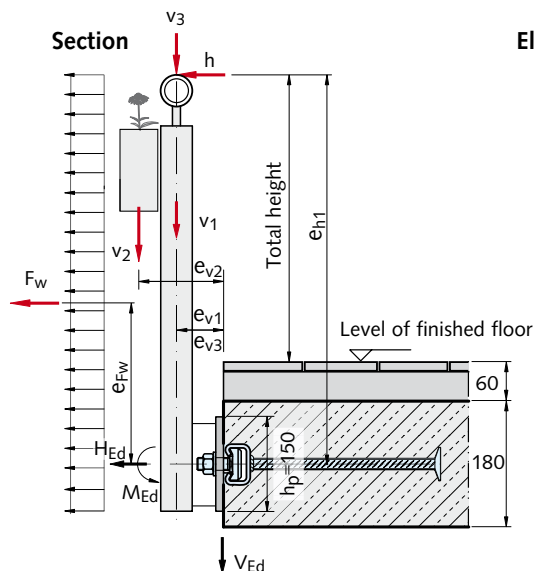

Elevation

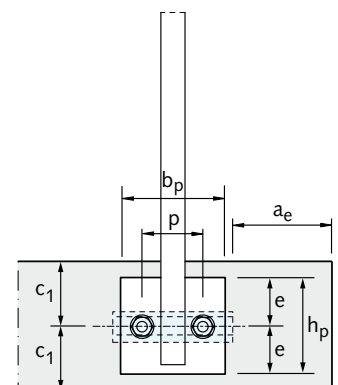

HALFEN HGB HANDRAIL CONNECTIONS

Calculation example

Calculation example

Post spacing	1.5 m
Post height from FFL	1.0 m
Structure height	9.0 m < 25.0 m
Banister load	0.5 kN/m (residential buildings)
Concrete slab thickness	180 mm

Distance channel axis to component edge	$c_1 = 90$ mm
Width of banister anchor plate	$b_p = 150$ mm
Height of banister anchor plate	$h_p = 150$ mm
Bolt spacing	$p = 80$ mm
Concrete strength	C30/37

Load

Vertical loads:

Dead load, banister including siding	$v_1 = 0.40$ kN/m
Dead load, flower box	$v_2 = 0.35$ kN/m
Vertical traffic load on the banister	$v_3 = 0.15$ kN/m

Horizontal loads:

Banister load	$h = 0.50$ kN/m
Wind force	$q = 0.50$ kN/m ² (according to DIN EN 1991-1-4 NA. B. 3)

(assumption: building height 9.0 m < 10.0 m, not susceptible to resonance frequency, inland wind zone 1)

Cantilevers:

$$e_{h1} = 1.0 + 0.06 + \frac{0.18}{2} = 1.15 \text{ m}$$

$$e_{Fw} = \frac{(1.15 + 0.075)}{2} - 0.075 = 0.53 \text{ m}$$

$$e_{v1} = 0.10 \text{ m}$$

$$e_{v2} = 0.20 \text{ m}$$

$$e_{v3} = 0.10 \text{ m}$$

Wind load bearing zone:

$$A = (1.00 + 0.06 + \frac{0.18}{2} + \frac{0.15}{2}) \cdot 1.5 = 1.84 \text{ m}^2$$

External pressure coefficient (acc. table 7.1 DIN EN 1991-1-4):

$$h/d = 1, \text{ area B}$$

$$c_{pe,1} = -1.1 \text{ (wind-suction)}$$

$$c_{pe,10} = -0.8 \text{ (wind-suction)}$$

according to DIN EN 1991-1-4 chapter 7.2.1

the following is valid:

$$1 \text{ m}^2 < A \leq 10 \text{ m}^2$$

$$c_{pe} = c_{pe,1} + (c_{pe,10} - c_{pe,1}) \cdot \lg A =$$

$$-1.1 + (-0.8 + 1.1) \cdot \lg 1.84 = -1.02$$

Wind suction:

$$F_w = c_{pe} \cdot q \cdot A = -1.02 \cdot 0.50 \cdot 1.84 = -0.94 \text{ kN}$$

Action per support:

Wind load $F_{w,Ed} = -0.94 \cdot 1.5 = -1.41$ kN (Suction)
with $\gamma_F = 1.5$

Banister $H_{Ed} = 0.5 \cdot 1.5 \cdot 1.5 = 1.13$ kN
with $\gamma_F = 1.5$

Dead load banister $V_{1Ed} = 0.40 \cdot 1.5 \cdot 1.35 = 0.81$ kN
with $\gamma_F = 1.35$

Load from flower box $V_{2Ed} = 0.35 \cdot 1.5 \cdot 1.35 = 0.71$ kN
with $\gamma_F = 1.35$

Vertical load on banister $V_{3Ed} = 0.15 \cdot 1.5 \cdot 1.5 = 0.34$ kN
with $\gamma_F = 1.5$

Determining bearing reactions H_{Ed} , V_{Ed} and M_{Ed}

Not classed as an utility (escape) balcony therefore combination with wind load is not required.

Load case 1: V + banister load

$$M_{Ed} = 0.81 \cdot 0.10 + 0.71 \cdot 0.20 + 0.34 \cdot 0.10 + 1.13 \cdot 1.15 = \mathbf{1.56 \text{ kNm}}$$

$$V_{Ed} = 0.81 + 0.71 + 0.34 = \mathbf{1.86 \text{ kN}}$$

$$H_{Ed} = \mathbf{1.13 \text{ kN}}$$

Load case 2: V + wind

$$M_{Ed} = 0.81 \cdot 0.10 + 0.71 \cdot 0.20 + 1.41 \cdot 0.53 = \mathbf{0.97 \text{ kNm}}$$

$$V_{Ed} = 0.81 + 0.71 = \mathbf{1.52 \text{ kN}}$$

$$H_{Ed} = \mathbf{1.41 \text{ kN}}$$

Selected:

HGB-E 49/30, l = 200 mm, stainless steel A4

Bolt spacing p = 80 mm

2 bolts HGB-M 50/30 M12, A4-70,

Required minimum reinforcement:

Stirrups 3 Ø 10, l_b = 300 mm

(see page 48 approval → app. 6, table 7),

Edge rebar 2 Ø 10

Splitting the moment into a load pair

$$N_{Ed} = \frac{M_{Ed}}{(e - 0.41 \cdot x)} + H_{Ed}$$

$$e = \frac{h_p}{2} = 75 \text{ mm} \quad (\text{see approval Z-21.4.1912 appendix 7})$$

$$x = 0.30 \cdot e = 0.30 \cdot 75 = 22.5 \text{ mm}$$

see page 49 (appendix 8/table 8b)

$$e - 0.41 \cdot x = 75 - 0.41 \cdot 22.5 = 65.8 \text{ mm}$$

HALFEN HGB HANDRAIL CONNECTIONS

Calculation example

Load case 1: V + banister load

$$N_{Ed} = \frac{1.56 \text{ kNm}}{0.0658 \text{ m}} + 1.13 \text{ kN} = \mathbf{24.84 \text{ kN}} \rightarrow \text{decisive}$$

$$V_{Ed} = \mathbf{1.86 \text{ kN}} \rightarrow \text{decisive}$$

Load case 2: V + wind

$$N_{Ed} = \frac{0.98 \text{ kNm}}{0.0658 \text{ m}} + 1.41 \text{ kN} = 16.30 \text{ kN}$$

$$V_{Ed} = 1.52 \text{ kN}$$

Verifications

Geometrical boundry conditions according to approval Z-21.4-1912 appendix 6, table 6 have been met.

Verification of steel capacity

Design resistance (steel) channel HGB 49/30 using 2 bolt fixing

$$N_{Rd,s} = 25.8 \text{ kN} \quad \text{see page 48 (appendix 8, table 8b)}$$

$$V_{Rd,s} = 25.8 \text{ kN}$$

Channel, centric pull load

$$\frac{N_{Ed}}{N_{Rd,s}} = \frac{24.84}{25.8} = 0.96 < 1 \quad \checkmark$$

Channel, shear load

$$\frac{V_{Ed}}{V_{Rd,s}} = \frac{1.86}{25.8} = 0.07 < 1 \quad \checkmark$$

Channel, interaction

$$\left(\frac{N_{Ed}}{N_{Rd,s}}\right)^2 + \left(\frac{V_{Ed}}{V_{Rd,s}}\right)^2 = \left(\frac{24.84}{25.8}\right)^2 + \left(\frac{1.86}{25.8}\right)^2$$

$$= 0.93 + 0.01 = 0.94 < 1 \quad \checkmark$$

Design resistance (steel) **bolt M12, A4-70**

$$N_{Rd,s,s} = \mathbf{31.6 \text{ kN}} \quad \text{see page 48 (appendix 8, tab.9)}$$

$$V_{Rd,s,s} = \mathbf{22.7 \text{ kN}}$$

Bolt, centric pull load

$$\frac{0.5 \cdot N_{Ed}}{N_{Rd,s,s}} = \frac{0.5 \cdot 24.84}{31.6} = 0.39 < 1 \quad \checkmark$$

Bolt, shear load

$$\frac{0.5 \cdot V_{Ed}}{V_{Rd,s,s}} = \frac{0.5 \cdot 1.86}{22.7} = 0.04 < 1 \quad \checkmark$$

Bolt, interaction

$$\left(\frac{0.5 \cdot N_{Ed}}{N_{Rd,s,s}}\right)^2 + \left(\frac{0.5 \cdot V_{Ed}}{V_{Rd,s,s}}\right)^2 = 0.39^2 + 0.04^2 = 0.15 < 1 \quad \checkmark$$

Verification of concrete capacity

Design resistance concrete

$$V_{Rd,c} = 11.7 \text{ kN}$$

see page 49 (appendix 8, table 8b)

$$M_{Rd,c} = 0.81 \cdot x \cdot b \cdot \frac{f_{ck}}{\gamma_{Mc}} \cdot (e - 0.41 \cdot x)$$

$$M_{Rd,c} = 0.81 \cdot 22.5 \cdot 150 \cdot \frac{30}{1.5} \cdot 65.8 = 3597615 \text{ Nmm}$$

$$= \mathbf{3.60 \text{ kNm}}$$

Concrete edge failure

$$\frac{V_{Ed}}{V_{Rd,c}} = \frac{1.86}{11.7} = 0.16 < 1 \quad \checkmark$$

$$\frac{M_{Ed}}{M_{Rd,c}} = \frac{1.56}{3.60} = 0.43 < 1 \quad \checkmark$$

$\frac{V_{Ed}}{V_{Rd,c}} = 0.16 < 0.333$ → According to the approval verification of interaction is not required, see page 46 (approval/ page 7).

Verifying the ratio between horizontal action and bending moment

$$\frac{H_{Ed}}{M_{Ed}} = \frac{1.13 \text{ kN}}{1.56 \text{ kNm}} = 0.72 < 1.5$$

→ Design model is applicable
see page 46 (approval/ page 6)

HALFEN HTU Cast-in channels

The advantages at a glance



The perfect technical solution for attaching trapezoidal steel sheet to concrete.

HALFEN HTU Cast-in channels and self-tapping screws have become a standard everyday solution in the construction industry.

Safe and dependable

- optimal shape of the anchoring elements means safe and low slip anchorage
- the polystyrene-filler prevents the drill or self-tapping-screws hitting concrete
- building authority approved

Quick and cost-effective

- simple installation
- quick and easy installation of trapezoidal sheeting
- two anchor designs, A_N and D for optimal adapting to planned reinforcement

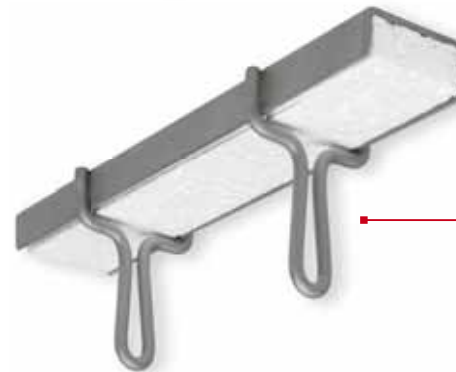

HALFEN HTU Cast-in channels
Anchor design A_N



HALFEN HTU Cast-in channels
Anchor design D

HALFEN HTU CAST-IN CHANNELS

Application Examples



Trapezoidal roof sheet metal attachment



Installing HALFEN HTU Cast-in channels in the front face of a slab



Façade fixed using HALFEN HTU Cast-in channels



Vertical HALFEN HTU Cast-in channels for connecting façade panels



Assembly of trapezoidal sheet metal using self-tapping screws



HALFEN HTU Cast-in channels in a pre-stressed concrete beam

1

HTA-CE Channels

2

HZA Channels

3

HGB Channels

4

HTU Channels

5

Roof and Wall

6

Curtain Wall

7

Accessories

HALFEN HTU CAST-IN CHANNELS

General, Materials

1

HTA-CE Channels

2

HZA Channels

3

HGB Channels

4

HTU Channels

5

Roof and Wall

6

Curtain Wall

7

Accessories

General

The **HALFEN Trapezoidal metal sheet installation channels** were developed in cooperation with the Association for the light-weight steel construction industry (IFBS *Industrieverband für Bausysteme im Stahlleichtbau*). Made as a C-shaped channel in stainless steel or hot-dip galvanized steel with at least two welded anchors, and approved by the German Institute of Building Technology (DIBt Deutsches Institut für Bautechnik).



Connecting elements between channel and steel trapezoidal profiles must be designed according to IFBS guidelines "Connections for use with constructions made of steel sheet cold profiles" or the relevant manufacturer's ETA (European Technical Approval).

Approval no. Z-21.4-84

Approval no. Z-14.1-4

Material / Corrosion protection

Hot-dip galvanized FV:

Dipped in a galvanising bath at a temperature of approximately 460°C. This method is used primarily for open-profile channels.

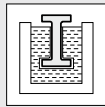

HALFEN HTU Cast-in channels, steel hot-dip galvanized

	Steel		
	Material	Standard	Zinc coating
Channel profiles	1.0038	DIN EN 10 025-2	FV: ≥ 50 µm
Anchor A _N , D	■		

Connecting elements: Galvanized Steel according to (IFBS) approval no. Z-14.1-4 or the relevant manufacturer's ETA.

Stainless steel A4:

Chromium is the important element in stainless steel. A specific chromium concentration ensures the generation of a passive layer on the surface of the steel that protects the base material against corrosion. The result is the high corrosion resistance of stainless steel.



- FV = Hot-dip galvanized steel 1.0038
- A4 = Stainless steel 1.4571/1.4404

HALFEN HTU Cast-in channels, steel hot-dip galvanized

	Stainless steel A4		
	Material	Standard	Corrosion resistance class according to EN 1993-1-4, table A.3
Channel profiles	1.4404 or 1.4571	DIN EN 10 088	III
Anchors A _N , D	■		

Connecting elements: Stainless steel as agreed and contracted from screw suppliers

HALFEN HTU CAST-IN CHANNELS

Installation, Assembly

Installation

The ready-to-install HTU Channel is embedded flush with the final concrete surface. It is advisable to level the concrete surface and to apply a slight slope to the outer edge of the concrete. This is to ensure that the trapezoidal sheet metal rests only on the HTU Channel. According to German approval a heightened installation of up to 5 mm is also possible.

Trapezoidal sheet metal fixing in wall applications

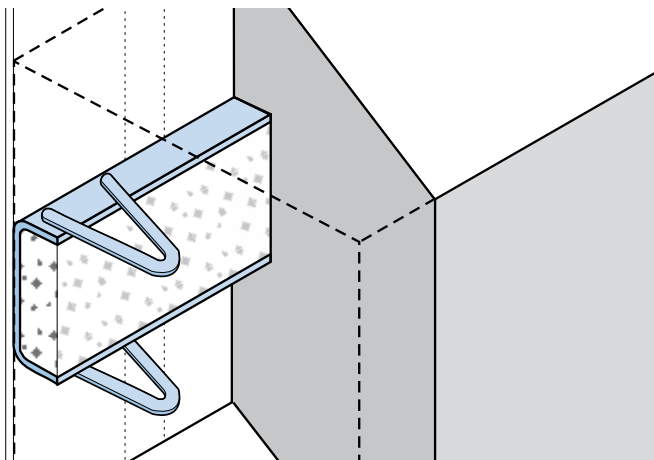

Alternatively, if the trapezoidal sheet metal manufacturer requires a minimal support width larger than 60 mm, this can be achieved through a flush channel installation and a flat concrete surface. Ensure that pre-stressed concrete trusses are properly aligned, centred and absolutely plane. Maintaining a 20 mm gap between individual channel ends is recommended.

Trapezoidal sheet metal fixing in roof applications

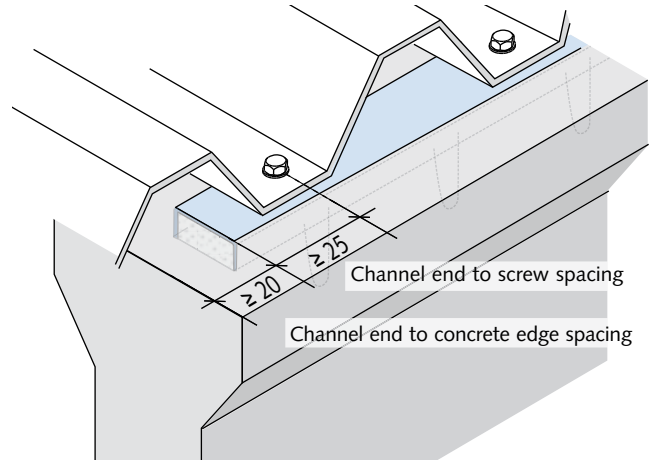

Screw placement

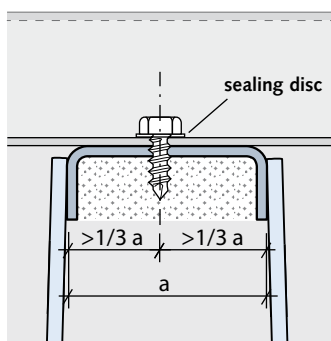

Recommended butt joint gap between two channels

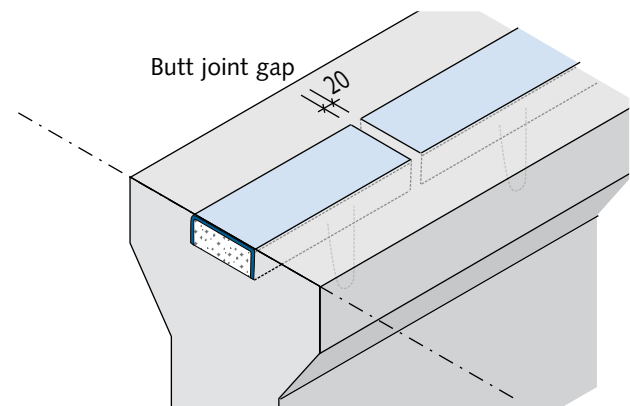

Assembly (with self-tapping screw)

- use a power-driver to fix the self-tapping screw; a pilot hole is not required. Even 4-fold overlapping at joints is not a problem with self-tapping screws
- use a power-driver with approximately 1500rpm and a size 10 socket
- suitable tools for various screws can be obtained from the screw supplier
- the trapezoidal sheet metal must be attached in the central third of the channel back; Screws must be positioned at a minimum distance of 25 mm from the channel ends

HALFEN HTU CAST-IN CHANNEL

Product Range

Type HTU 60/22/3

Type HTU 60/22/6

Profile cross-section A	2.81 cm ²		4.94 cm ²	
Moment of inertia I _y / Moment of resistance w _y	1.13 cm ⁴ / 0.71 cm ³		1.84 cm ⁴ / 1.27 cm ³	
Profile weight including anchors	2.49 kg/m	2.50 kg/m	4.25 kg/m	4.26 kg/m

Connecting element HTU material stainless steel channel thickness 3 mm
 e.g. JT3-3H-5,5x25-E16 with 4.5 mm pre-drilled or JZ7-6,3x22-E16 with 5.3 mm pre-drilled.
 - no approval -
 Coordination with the screw suppliers is required

Connecting element HTU material steel→ETA 10/0200:
 Self-tapping screws 6.3x19
 e.g. JT2-6-6,3-19-xE16 with sealing disc.
 Connecting element is exposed to weather: JT3-6-6.3x25-E16 (Wall) or JZ3-6-6.3x25-E22 (Roof)

Connecting element HTU material steel→ETA 10/0200:
 Self-tapping screws 6.3x22
 e.g. JT2-6-6,3-x22-V16 with sealing disc or cartridge fired nails SBR-14.
 Connecting element is exposed to weather: see left

Ordering example:

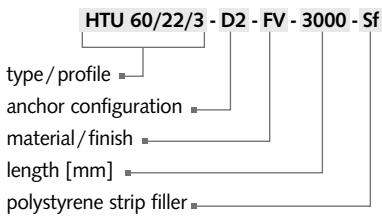

HTU 60/22/3	Number of anchors	HTU 60/22/6	Number of anchors
■ = hot-dip galvanized		■ = hot-dip galvanized	
HTU 60/22/3 - AN2 - FV - 3000 - Sf	8	HTU 60/22/6 - AN2 - FV - 3000 - Sf	8
HTU 60/22/3 - D2 - FV - 3000 - Sf	8	HTU 60/22/6 - D2 - FV - 3000 - Sf	8
HTU 60/22/3 - AN3 - FV - 3000 - Sf	20	HTU 60/22/6 - AN3 - FV - 3000 - Sf	20
HTU 60/22/3 - D3 - FV - 3000 - Sf	20	HTU 60/22/6 - D3 - FV - 3000 - Sf	20
■ = Stainless steel A4		■ FV = Steel S235JR, hot-dip galvanized	
HTU 60/22/3 - AN2 - A4 - 3000 - Sf	8	■ A4 = Stainless steel 1.4571/1.4404 ①	
HTU 60/22/3 - D2 - A4 - 3000 - Sf	8		
HTU 60/22/3 - AN3 - A4 - 3000 - Sf	20		
HTU 60/22/3 - D3 - A4 - 3000 - Sf	20		

Anchor spacing:

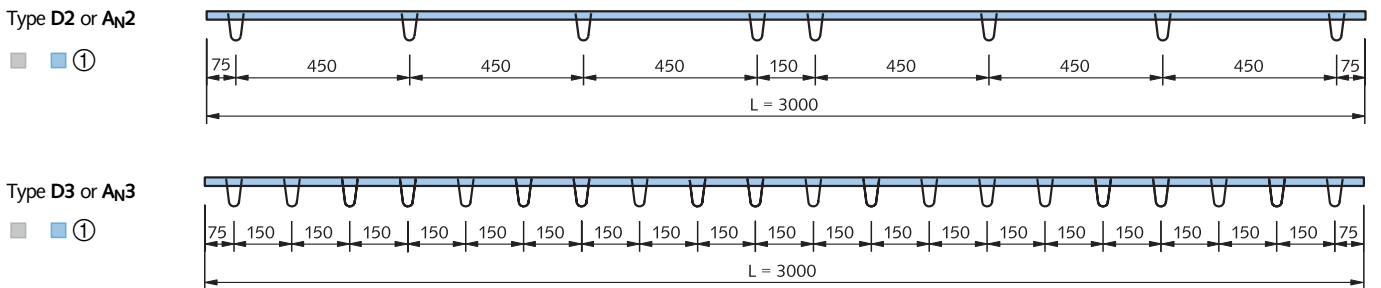

① Material A4 available only in 3 mm thickness

Dimensions in [mm]

Identification HTU

A yellow identification label is fixed to the back of each channel.

HTU 60/22/3 Type AN
 (Steel 1.0038 1.4404/1.4571, thickness 3 mm)
 for screw-fastening of trapezoidal sheet metal with hexagonal sheet metal or self-tapping screws

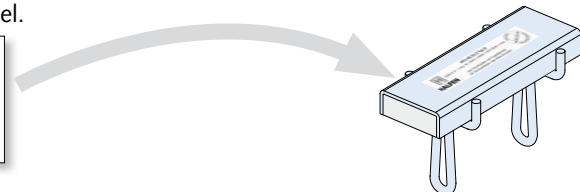

HALFEN HTU CAST-IN CHANNELS



Dimensioning

Table 1 Maximum design load-carrying capacity F_{Ed}

Profile HTU	Anchor spacing s [mm]	max. F_{Ed} [kN]		max. F_{Ed} [kN]		max. evenly distributed load q_{Ed} [kN/m]		
		$p = s$	$p = s/2$	$p = s/2$	$p = s/2$			
60 / 22 / 3	450	$p = s$	$p = s/2$	$p = s/2$	3.5	4.6		
	150					7.0	46.6	
60 / 22 / 6	450					7.0	3.5	15.5
	150					7.0	3.5	46.6

$\sqrt{N_{Ed}^2 + V_{xEd}^2 + V_{yEd}^2} \leq \text{max. } F_{Ed}$ Concrete \geq C20/25

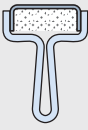
Table 2 Minimum distance when exploiting maximum load as in table 1

Profile	Minimum interaxial spacing and edge distance					
	a_a ① [mm]	a_r ② [mm]	a_e ③ [mm]	a_f ④ [mm]	h ⑤ [mm]	b ⑥ [mm]
HTU { 60/22/3 60/22/6						
 Type AN	200	100	20	20	100 + nom c	200
 Type D	200	100	20	20	75 + nom c	200

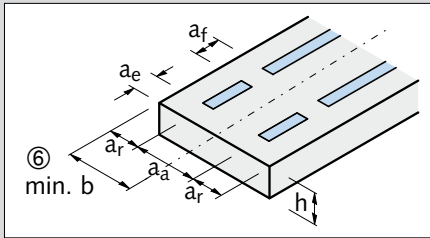

① If the (trapezoidal sheet metal) channels are placed so that the anchors of adjacent channels are offset by at least 200 mm, the axial spacing a_a may be reduced to 80 mm.

② If not exploiting the maximum load capacity F_{Ed} , see table above, the edge distance a_r may be reduced. This applies only for central tensile stress N_{Ed} .

$$a_{r \text{ red.}} = \frac{\text{actual } N_{Ed}}{\text{max. } F_{Ed}} \times a_r \geq 50 \text{ mm}$$

actual N_{Ed} = design rating of actual load
max. F_{Ed} = maximum load as in the table above

The edge distances must not be reduced if transverse stress (V_{xEd} , V_{yEd}) is present.

③ With full exploitation of maximum load F_{Ed} as in the table above, the last anchor must be at least 100 mm from the component edge.

④ When fully exploiting maximum load capacity F_{Ed} , see table above, the "last anchors" of adjacent channels must be at least 150 mm apart.

⑤ Depends on the anchor's size and the required concrete cover.

⑥ Minimum width of building component for a one channel layout.

Roof and Wall

The advantages at a glance

1

HTA-CE Channels

2

HZA Channels

3

HGB Channels

4

HTU Channels

5

Roof and Wall

6

Curtain Wall

7

Accessories

The efficient and established installation systems for timber roof structures, masonry restraints and connectors for concrete façades are proven practical solutions for the construction industry, greatly improving construction time with significant cost-saving.

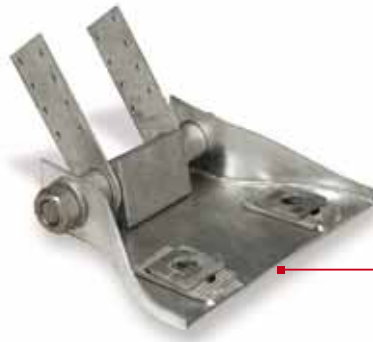

HALFEN HSF Rafter shoe

Suitable for horizontal forces acting on rafter and collar beam roofs.

HALFEN HNA Timber fixing strap

Suitable for all acting loads e.g. wind loads in roof structures.

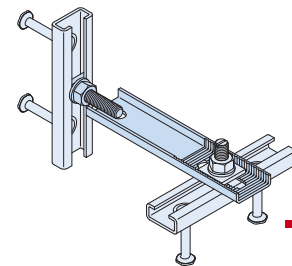

HALFEN HKZ Restraint ties

HALFEN SPV Turnbuckle restraint

For connection of tensile and compression loads from concrete walls elements.

HALFEN ML+BL Brick tie anchor system

For connection of tension and compression loads from concrete walls elements.



HALFEN HVL-M Precast connection HALFEN HVL-E Cast-in channel

Suitable for horizontal loads in concrete wall elements (loads perpendicular to the bracket).

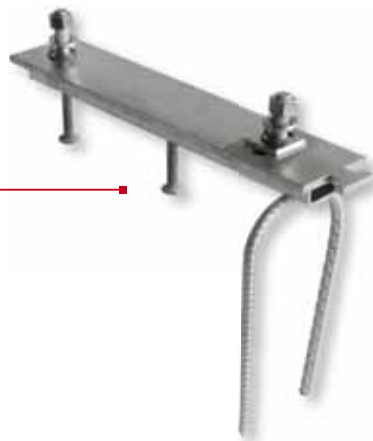

HALFEN HKW

Corner guard

Wall and column

corner protector;

application in industry and parking structures.



HALFEN HTU CAST-IN CHANNELS

Application Examples



HALFEN HSF Rafter shoe 6/12



HALFEN HKZ Restraint tie with serrated washer



Airbus paintshop with HALFEN HVL Restraint tie



HVL-System in precast building components



Connecting construction timbers to concrete using the HNA



Timber roof construction with HALFEN HNA Fixing straps



Corner guards in an industrial environment



HALFEN ML Brick-ties anchor system

ROOF & WALL

HALFEN Rafter Shoe HSF

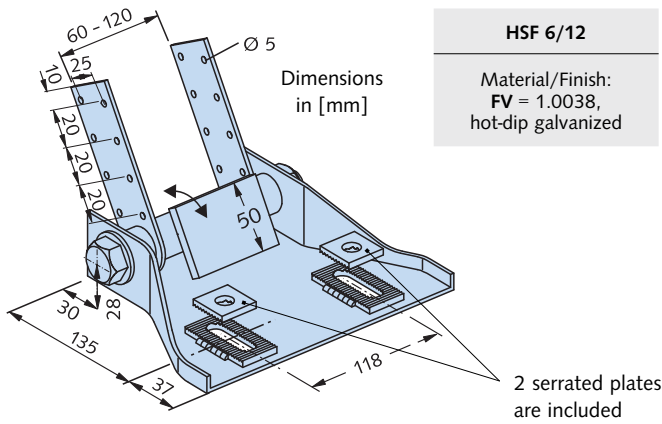

In modern wood constructions, rafter shoes type HSF 6/12 are used to support the horizontal forces in rafter and collar tie roofs.

The advantages at a glance:

- minimal planning; simply specify the profile and position of the HALFEN Cast-in channels in the concrete element
- clear statics with flexible rafter shoes
- complex and therefore costly support structures are not necessary
- simple and unproblematic roof constructions:
 - a) adjustable support plate
 - b) adjustable nailing brackets for vertical anchorage for various rafter widths from 60 to 120 mm
 - c) adjustable in longitudinal rafter axis ± 15 mm
- freely adjustable rafter spacings in the longitudinal axis of the HALFEN Channel without additional measures
- hot-dip galvanized for excellent corrosion protection

Example

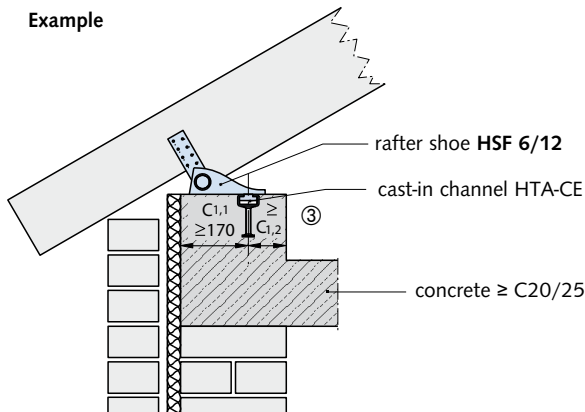

Definition $c_{1,1}$ and $c_{1,2}$ see page 15

The horizontal forces are transferred into the main concrete structure using (ETA) European Technical approved HALFEN HTA-CE Cast-in channels.

During assembly ensure that the serration in the counter plates engages in the base plate. The marking on the counter plates must be at right angles to the slot in the base plate.

Rafter roof static system:

$$F_{1,d} < F_{Rd}$$

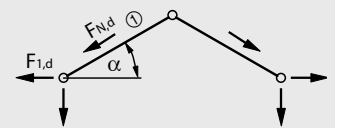

Design values F_{Rd}			
Load F_{Rd}	Required HALFEN Cast-in channel	Min. edge distance ②	Required HALFEN Bolt
[kN/Rafter]	Type	$C_{1,2}$ [mm]	Type dimensions
12.6	HTA-CE 38/17	75	HS 38/17 - M16 x 40
16.8	HTA-CE 40/22 HTA-CE 40/25	100	HS 40/22 - M16 x 50
19.6	HTA-CE 50/30 HTA-CE 49/30	150	HS 50/30 - M16 x 50

- ① The maximum rafter strength is limited by the design load of each individual component of the rafter shoe. Load tests resulted in a mean breaking load of 50 kN. With normal loads larger than the recommended load capacity (= about $\frac{1}{3}$ of the breaking load), the rafter spacing may need to be reduced.
- ② If lower loads are present then the minimum edge distance $C_{1,2}$ for the HALFEN Cast-in channels can be reduced. The distance to the concrete edge must be at least 170 mm.
- ③ Make sure that the HALFEN Cast-in channels are installed flush with the concrete surface. Use spacers if necessary.

ROOF & WALL

HALFEN HNA Timber Fixing Strap

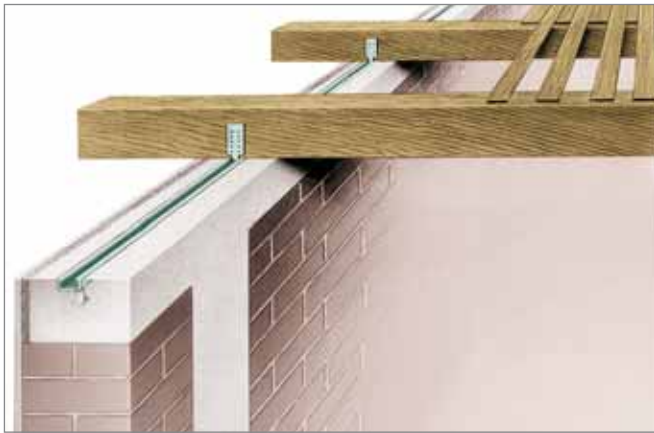

Typical installation of timber beams using HNA nailing straps with HALFEN Cast-in channels embedded in concrete.

Type selection

Dimensions in [mm]

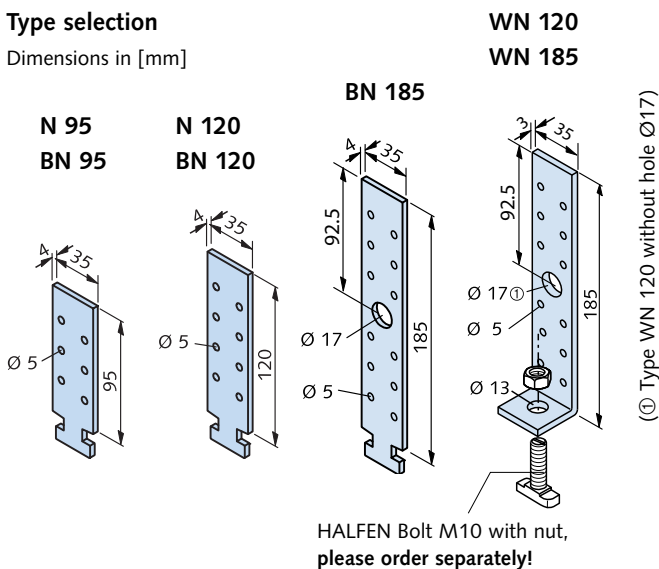

To provide an optimal base for roof framework, continuous HTA-CE HALFEN Cast-in channels or HTA-CE HALFEN Cast-in channel short elements are cast in the concrete; suitable for concrete ring beams or slabs. The type of HTA-CE HALFEN Cast-in channels, nailing straps and nails depend on the assumed loads (e.g. wind force).

For calculation and design criteria see:

- DIN EN 1991-1-4 (EC1) und DIN EN 1991-1-4/NA
- DIN EN 1995-1-1 (EC5)

The timber fixing straps can be positioned on one or both sides of the timber beams or rafters. Refer to the following table for F_{Rd} load capacities. The beams / framework must be secured against twisting when straps are used only on one side of the beams, (e.g. by nailing to the upper wood roof boarding).

Ordering example:

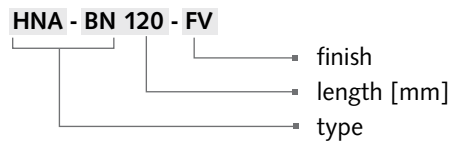

Assembly example:

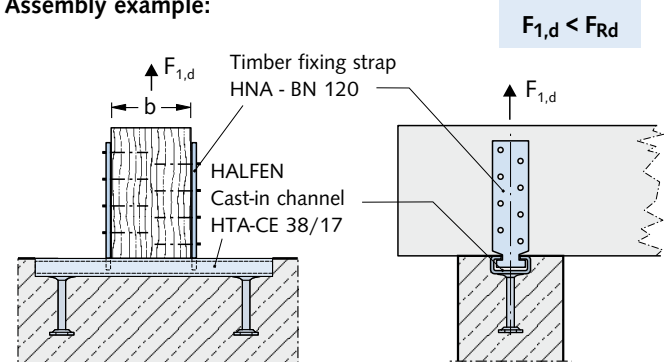

Type selection, timber fixing straps

Suitable for HALFEN Cast-in channel:	Material/Finish FV = 1.0038, hot-dip galvanized	Design value for load capacity F_{Rd} [kN] per beam attachment			Attaching timber fixing straps to wooden beams/rafters	
		Position of timber fixing straps			Wire nails	Anchor nails
		Single-sided	Double-sided			
Item name: length [mm]			for $b \geq 60$ mm	$b \geq 100$ mm		
HTA-CE 28/15 hot-dip galvanized (FV)	HNA - N 95 - FV	4.2	4.9	5.6	according to DIN EN 10230-1	according to the manufacturer's technical approval
	HNA - N 120 - FV					
	HNA - WN 120 - FV	1.4	2.8	2.8		
	HNA - WN 185 - FV					
HTA-CE 38/17 hot-dip galvanized (FV)	HNA - BN 95 - FV	6.3	7.5	8.4		
	HNA - BN 120 - FV					
	HNA - BN 185 - FV	1.4	2.8	2.8		
	HNA - WN 120 - FV					
HNA - WN 185 - FV						

ROOF & WALL

Brick Tie Anchor Systems ML + BL

HALFEN ML and BL Brick tie anchors are tried and tested efficient installation systems for securing brick walls, masonry in-fills, partition walls, brick renders (with or without ventilation gap and heat insulation) to concrete

walls, concrete supports, steel or wooden structures.

The brick tie anchors are able to move freely in the brick tie channels, considerably reducing cracks caused by masonry settlement.

All HTA-CE and HMS profiles have a foam filling to prevent concrete ingress. The channels are attached to the formwork using standard nails.

The HALFEN Brick tie anchors are inserted at the recommended intervals (static requirements) in the brick wall during construction (see page 65). The anchors are inserted in the brick tie channels, laid flat between the rows of brick and pressed into the mortar. The perforations in the anchors optimise anchorage with the mortar.

Plan view; wall attachment

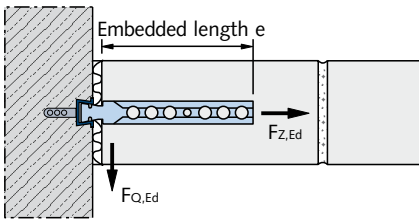

Plan view; facing brickwork attachment

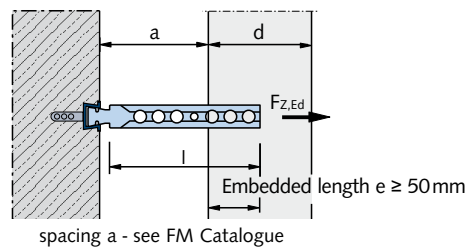

Brick tie anchor ML in combination with HALFEN Cast-in channels 25/15-D and 28/15

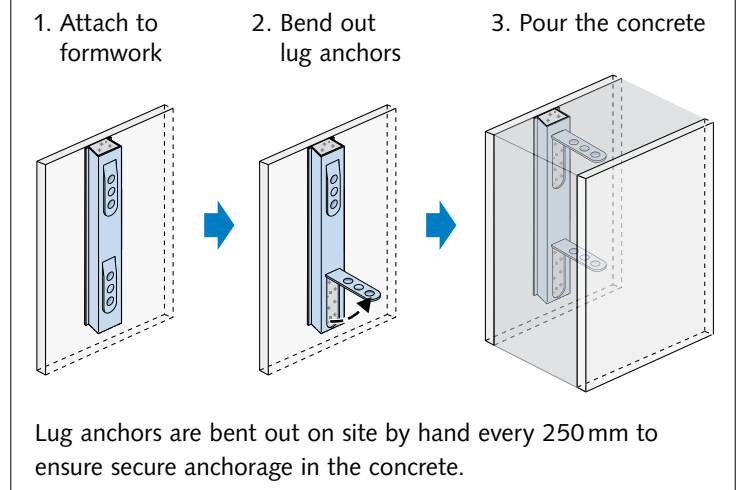
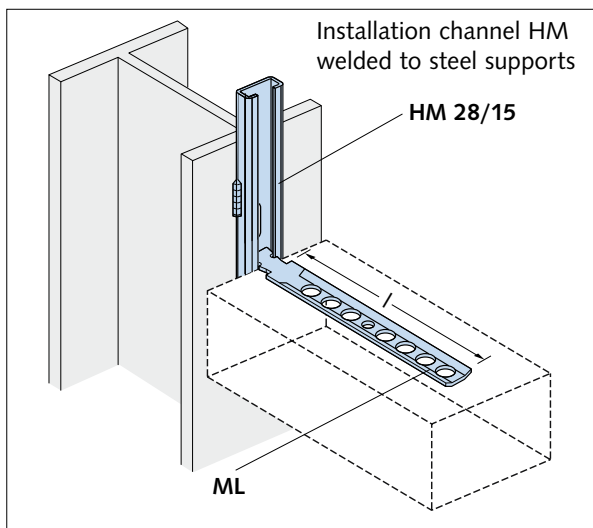
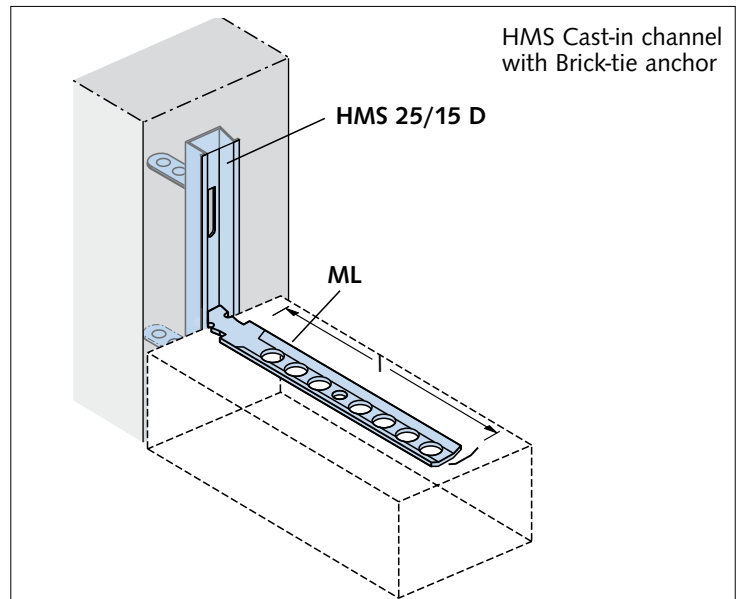
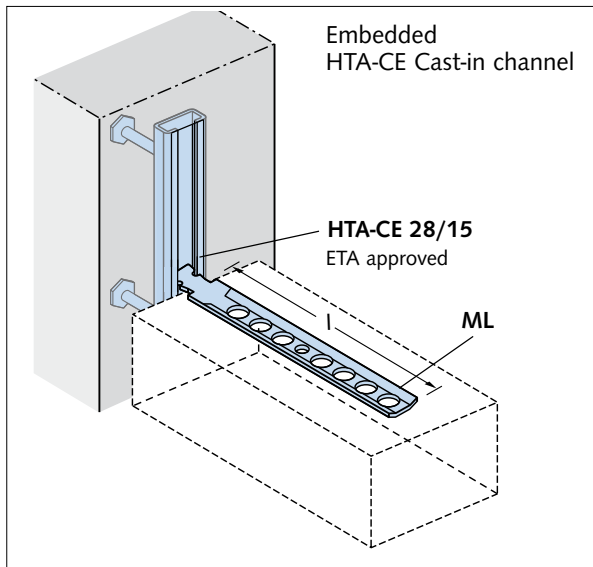

1 HTA-CE Channels
2 HZA Channels
3 HGB Channels
4 HTU Channels
5 Roof and Wall
6 Curtain Wall
7 Accessories

ROOF & WALL

Brick Tie Anchor Systems, ML + BL HALFEN Anchor Bolt Systems

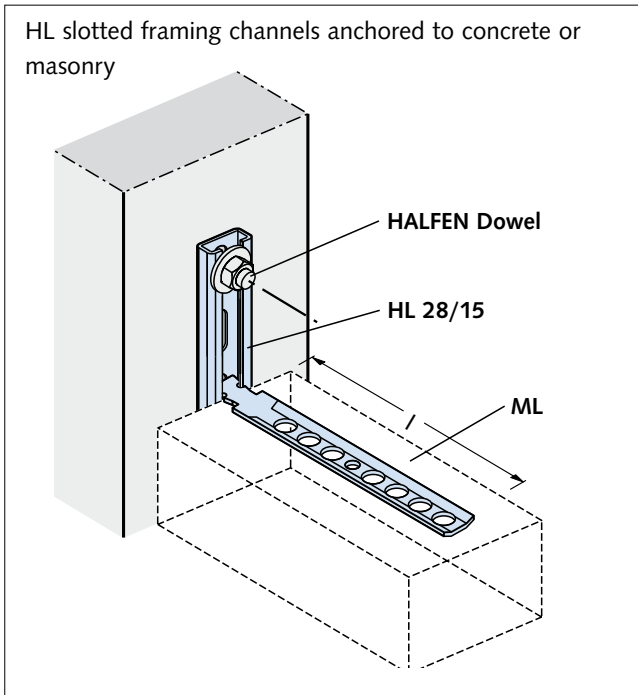

Top view

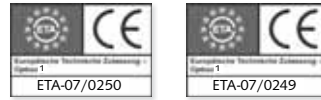
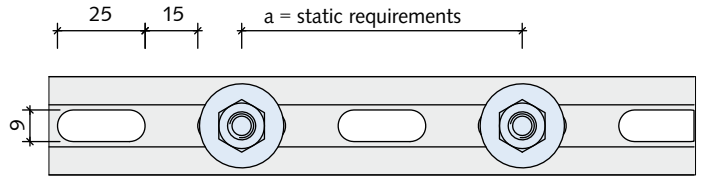

Bolt anchor HB-BZ-U



HALFEN Anchor bolt system: For more information on application and assembly see Technical Product Information **HALFEN HB**

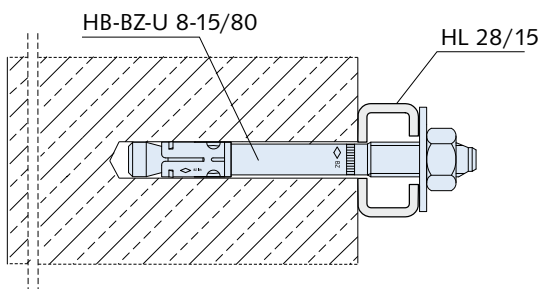

Bolt anchor HB-BZ-U 8-15/80

- galvanized or stainless steel (A4)
- approved for **cracked and uncracked concrete**
- with large washer DIN 9021/EN ISO 7093

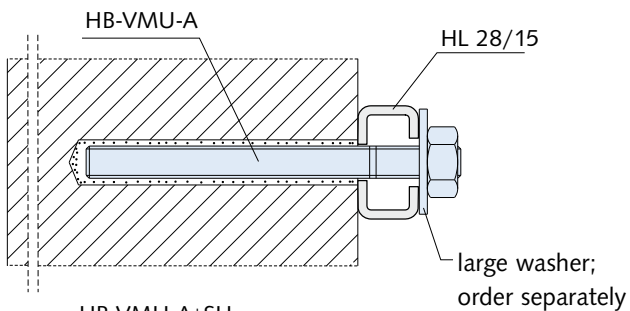

Anchor rod HB-VMU-A 8-20/110

- galvanized or stainless steel (A4)
- approved for **monolithic masonry**
- with large washer DIN 9021/EN ISO 7093 (order separately)

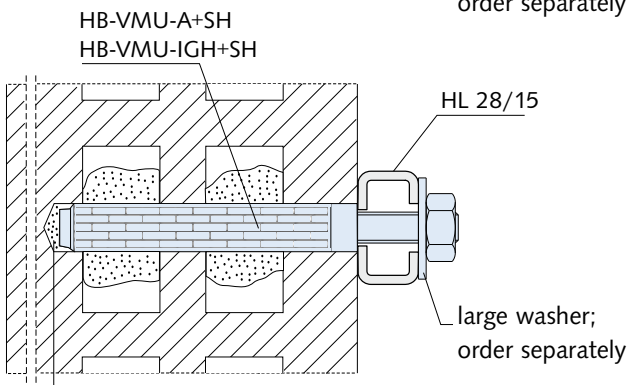

Anchor rod HB-VMU-A 8-20/110 with Perforated sleeve HB-VMU-SH 14x100 or

Internal threaded sleeves HB-VMU-IGH M8 with Perforated sleeve HB-VMU-SH 16x100

- galvanized or stainless steel (A4)
- approved for **perforated brick masonry**
- large washer, see above

ROOF & WALL

Brick Tie Anchor Systems ML + BL

Brick tie anchors

ML, BL

- max. load $F_{Z,Ed} = 0.32 \text{ kN}$ per cm embedment length e
- max. $F_{Z,Ed} \leq 3.2 \text{ kN} = F_{Z,Rd}$
- max. $F_{Q,Ed} \leq 2.7 \text{ kN} = F_{Q,Rd}$

ML 1

- max. $F_{Z,Ed} \leq 2.5 \text{ kN} = F_{Z,Rd}$
- max. $F_{Q,Ed} \leq 1.4 \text{ kN} = F_{Q,Rd}$

Observe profile load capacity!

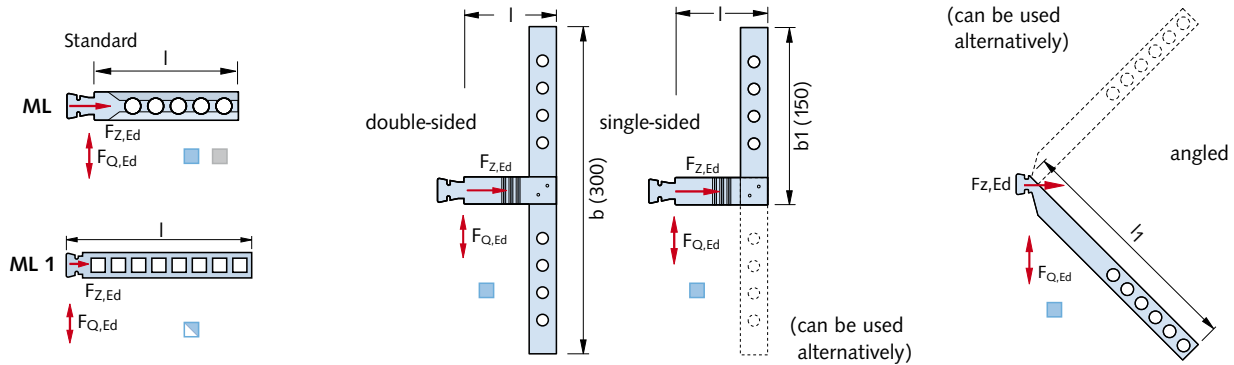
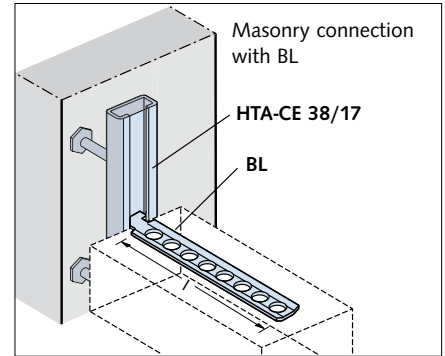
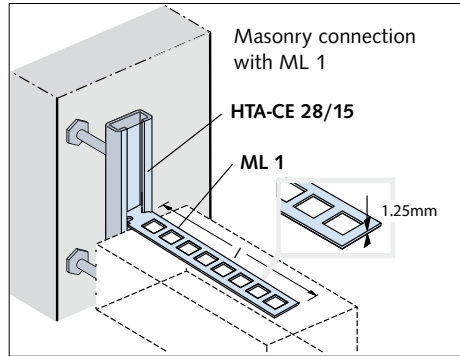

Brick tie anchor		Brick tie anchor									
	HMS 25/15 D L = 2500 mm		ML Standard		ML 1		MLQ - D ² Double-sided		MLQ - E ² Single-sided		MLS Slanted
			26 × 2 [mm]		25 × 1.25 [mm]		25 × 3 [mm]		25 × 3 [mm]		22 × 3 [mm]
	HTA-CE 28/15 L = 1050 mm ¹ L = 6070 mm ¹	Type	Length l [mm]	Type	Length l [mm]	Type	Length l [mm]	Type	Length l [mm]	Type	Length l ₁ [mm]
			ML - 85		ML 1 - 125		MLQ-D - 85		MLQ-E - 85		MLS - 300
	HL 28/15 L = 6070 mm ¹		ML - 120		ML 1 - 185		MLQ-D - 120		MLQ-E - 120		MLS - 350
			ML - 180		ML 1 - 245		MLQ-D - 180		MLQ-E - 180		MLS - 400
	HTA-CE 38/17 L = 1050 mm ¹ L = 6070 mm ¹	BL Standard 30 × 2 [mm]		BLQ - D ² Double-sided 30 × 3 [mm]		BLQ - E ² Single-sided 30 × 3 [mm]		Material:			
		Type	Length l [mm]	Type	Length l [mm]	Type	Length l [mm]	■ FV = Steel 1.0038, Hot-dip galvanized ■ SV = Steel DX51D + Z275, Sendzimir galvanized ■ A4 = Stainless steel 1.4571/1.4404 ■ A2 = Stainless steel 1.4307			
			BL - 85		BLQ-D - 85		BLQ-E - 85	① Other lengths: Available on request ② Thickness in the overlap area: 6 mm (2×3 mm)			
			BL - 120		BLQ-D - 120		BLQ-E - 120				
			BL - 180		BLQ-D - 180		BLQ-E - 180				

Debond sleeve ML-G 150 for wall attachments, suitable for ML - anchors

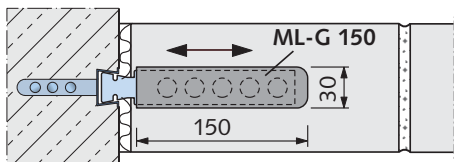

Permits movement in the longitudinal anchor direction, e.g. in long masonry bonds or partition walls adjoining concrete load bearing structures; prevents cracks forming.

ML-G 150, material: soft PVC, material thickness 1.5 mm

ROOF & WALL

Firewall Connections with Wall Connecting Systems ML + BL

Firewall connection according to DIN 4102-4: 2016-05

Solid masonry fire walls

Statically required connections of load bearing, room enclosing, masonry walls can also be designed as fire walls in accordance with DIN 4102-4 section 9.8.4 using HALFEN Brick tie channels.

The anchorage to adjacent components (steel reinforced concrete supports or walls) meet the requirements for stability and fire resistance if the anchorage conforms to the standards set in DIN 4102-4 section 9.8.4 (figure 9.13, variant 2).

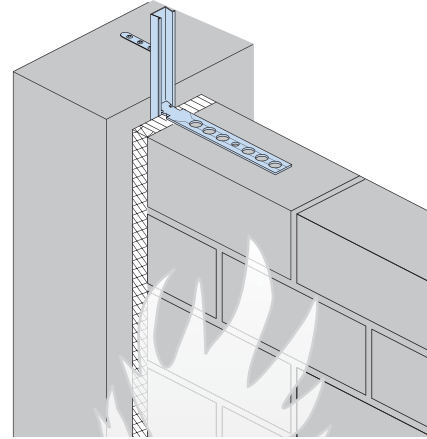

Connection of a load bearing masonry wall as a fire wall according to DIN 4102-4 section 9.8.4 (figure 9.13) or according to DIN EN 1996-1-2: 2011-04 (figure E.4B)

Horizontal section

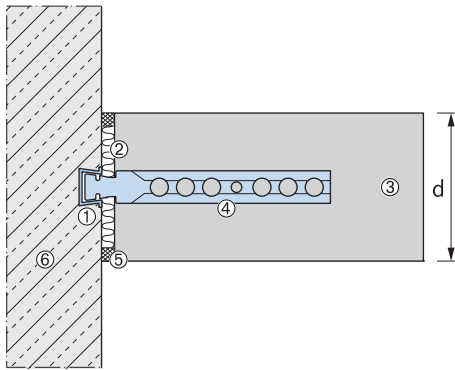

Vertical section

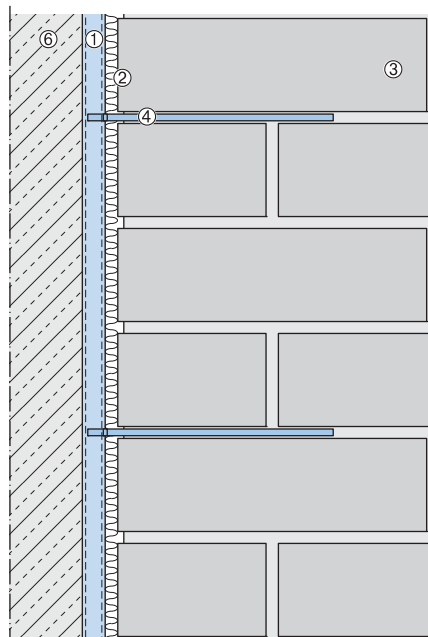

Definition, DIN regulations

① HALFEN Cast-in channel

② Insulation layer:

According to DIN 4102-4 section 9.2.14 insulation layers in connecting joint gaps must "[...] be made of non-flammable mineral fibre; have a melting point $\geq 1000^{\circ}\text{C}$ as stated in DIN 4102-17; and have a gross density of $\geq 30\text{ kg/m}^3$ and must not smoulder".

③ Masonry:

Bricks (gross density class) and minimum wall thickness according to DIN EN 1996-1-2: 2011-04.

④ Masonry connection (vertically adjustable)

⑤ Expansion joint

⑥ Concrete

Product information

HALFEN Cast-in channel type ①	④ Brick tie anchor (see page 62 ff.)	
	for standard grout	for thin mortar
HMS 25/15 D	ML	ML 1
HTA 28/15	ML	ML 1
HTA 38/17	BL	-

Anchor spacings

HALFEN Brick tie anchors can be used at any position along the whole length of the brick tie channel. Generally the standard spacing between the anchors is 250 mm (4 anchors per metre).

ROOF & WALL

Restraint with Turnbuckle SPV

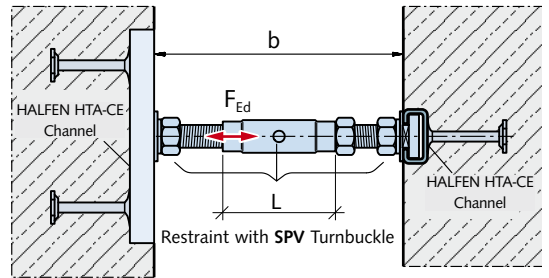
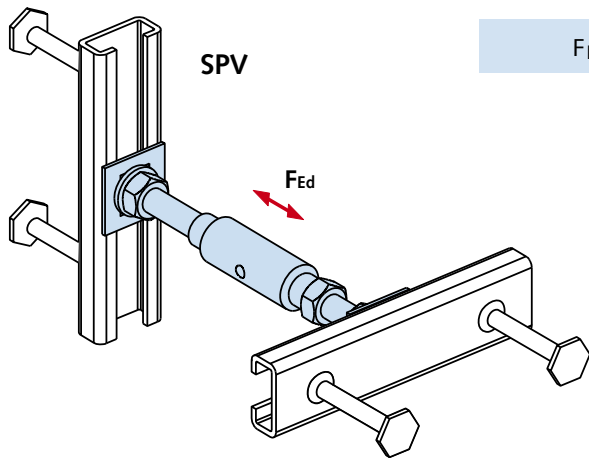

Ensure adequate screw depth:
 M12 → ≥ 10 mm
 M16 → ≥ 13 mm

Product description

The restraint with turnbuckle SPV is suitable for compressive and tensile loads up to $F_{Ed} = 14.0\text{ kN}$ and for clearances up to 200 mm. By turning the clamping sleeve (sleeve has a right and left-hand thread), the clearance can be freely adjusted within the given range. Connected to building structure using HALFEN Cast-in channels (order separately).

Included in delivery

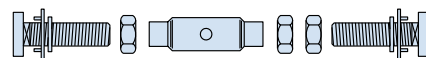

- Turnbuckle SPH
- 2 HALFEN Bolts (1 right-hand thread, 1 left-hand thread)
- 3 standard nuts
- 2 washers and
- 2 locking washers SIC

Ordering example:

Item name: **SPV - 7,0 - 100 - A4**

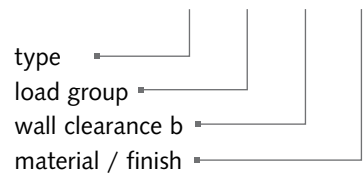

! HALFEN Cast-in channels must be ordered separately

HALFEN SPV Restraint with turnbuckle										
Load capacity F_{Rd} [kN]		± 7.0			± 9.8			± 14.0		
Type	Stand-off distance	HALFEN Bolt left-hand thread	Sleeve	HALFEN Bolt right-hand thread	HALFEN Bolt left-hand thread	Sleeve	HALFEN Bolt right-hand thread	HALFEN Bolt left-hand thread	Sleeve	HALFEN Bolt right-hand thread
	b [mm] ②	M12 [mm]	L [mm]	M12 [mm]	M16 [mm]	L [mm]	M16 [mm]	M16 [mm]	L [mm]	M16 [mm]
SPV	100±10	50	60	40	50	60	40	-	-	-
	120±15	50	75	40	50	75	40	-	-	-
	140±15	50	75	60	50	75	60	80	60	50
	160±15	50	95	60	50	95	60	80	75	60
	180±15	50	115	60	50	115	60	80	95	60
	200±15	50	135	60	50	135	60	80	115	60
HALFEN Cast-in channel		HTA-CE 38/17 ①			HTA-CE 38/17 ①			HTA-CE 49/30 ①		

① Short elements 150, 200 and 250 ② With F_{Rd} -load group 9.8kN restricted to negative tolerance



For further concrete façades accessories see **Catalogue Concrete Façade FB**

ROOF & WALL

Restraint Tie HKZ

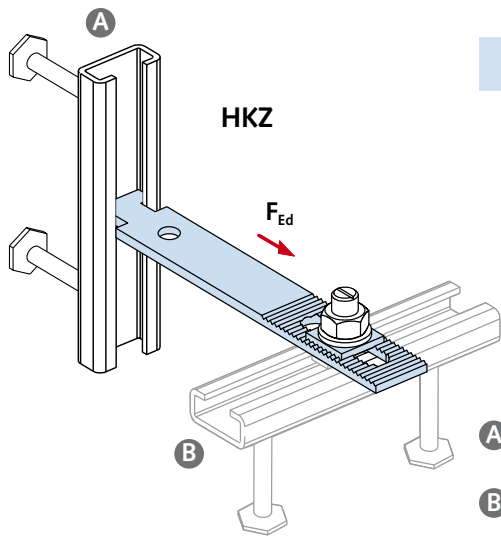

$F_{Ed} = \text{load}$

- A** HALFEN Channel suitable for HKZ-Restraint ties
- B** HALFEN Channel or permitted dowel according to approval

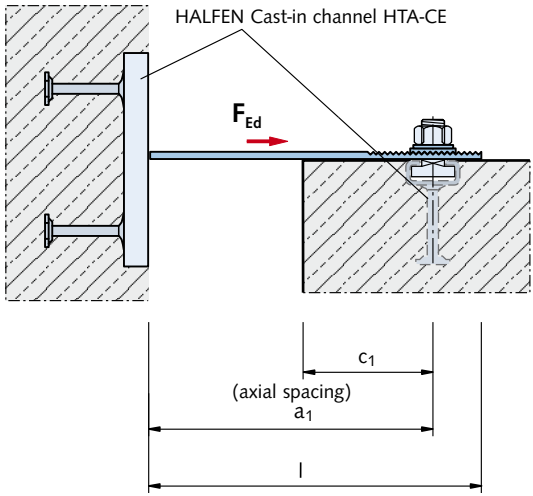

Product characteristics

The serrations in the bracket and in the washer ensure positive static load transmission.

Two HALFEN Cast-in channels embedded at right angle to each other in the concrete ensure three-dimensional adjustability.

Ordering example:

Item name: **HKZ-38/17 - 100 - A4**

type —————

clearance a_1 —————

material / finish —————

Please order HALFEN Cast-in channels and HALFEN Bolts and washers separately

HALFEN HKZ Restraint tie								
Characteristics:	Type selection: GV = galvanized. Not suitable for façades with ventilation gaps		Type selection: A4 = Stainless steel grade 1.4571/1.4404		Dimensions			
	Type	a_1 [mm]	Type	a_1 [mm]	Length l [mm]	Spacing a_1 [mm]	Tolerance [mm]	Holes [mm]
+4.9 (tension only)	HKZ 28/15 - 50 - GV		HKZ 28/15 - 50 - A4		90	50	$a_1 \pm 20$	LL 11 x 55
	HKZ 28/15 - 75 - GV		HKZ 28/15 - 75 - A4		115	75		LL 11 x 55
	HKZ 28/15 - 100 - GV		HKZ 28/15 - 100 - A4		140	100		
	HKZ 28/15 - 125 - GV		HKZ 28/15 - 125 - A4		165	125		RL 11
	HKZ 28/15 - 150 - GV		HKZ 28/15 - 150 - A4		190	150		
	HKZ 28/15 - 175 - GV		HKZ 28/15 - 175 - A4		215	175		
	HKZ 28/15 - 200 - GV		HKZ 28/15 - 200 - A4		240	200		
	HKZ 28/15 - 225 - GV		HKZ 28/15 - 225 - A4		265	225		
HKZ 28/15 - 250 - GV		HKZ 28/15 - 250 - A4		290	250			
+9.8 (tension only)	HKZ 38/17 - 75 - GV		HKZ 38/17 - 75 - A4		115	75	$a_1 \pm 20$	LL 13 x 55
	HKZ 38/17 - 100 - GV		HKZ 38/17 - 100 - A4		140	100		LL 13 x 55
	HKZ 38/17 - 125 - GV		HKZ 38/17 - 125 - A4		165	125		
	HKZ 38/17 - 150 - GV		HKZ 38/17 - 150 - A4		190	150		RL 13
	HKZ 38/17 - 175 - GV		HKZ 38/17 - 175 - A4		215	175		
	HKZ 38/17 - 200 - GV		HKZ 38/17 - 200 - A4		240	200		
	HKZ 38/17 - 225 - GV		HKZ 38/17 - 225 - A4		265	225		
	HKZ 38/17 - 250 - GV		HKZ 38/17 - 250 - A4		290	250		
	HKZ 38/17 - 275 - GV		HKZ 38/17 - 275 - A4		315	275		
HKZ 38/17 - 300 - GV		HKZ 38/17 - 300 - A4		340	300			

① The load capacities apply for the HKZ-restraint ties. The channels **A** and the fixings **B** must be verified case by case, depending on the concrete strength, the reinforcements and the edge distance c_1 .

1 HTA-CE Channels
 2 HZA Channels
 3 HGB Channels
 4 HTU Channels
 5 Roof and Wall
 6 Curtain Wall
 7 Accessories

ROOF & WALL

Restraint Tie HKZ - GF / GU

1 HTA-CE Channels

2 HZA Channels

3 HGB Channels

4 HTU Channels

5 Roof and Wall

6 Curtain Wall

7 Accessories

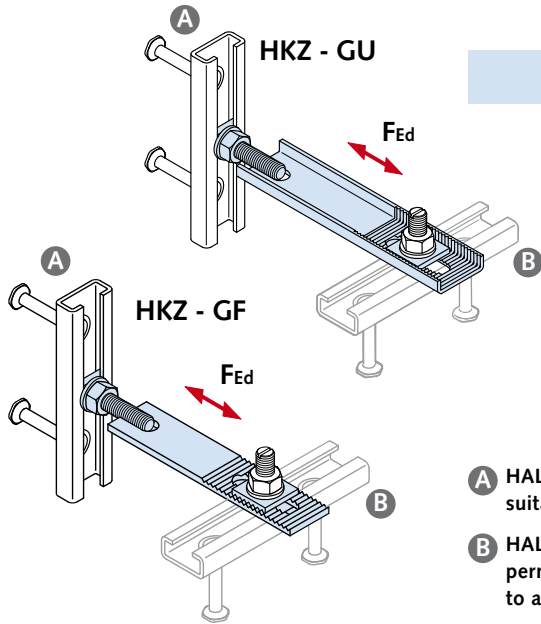

$F_{Ed} = \text{load}$

- A HALFEN Channel suitable for HKZ-Restraint ties
- B HALFEN Channel or permitted dowel according to approval

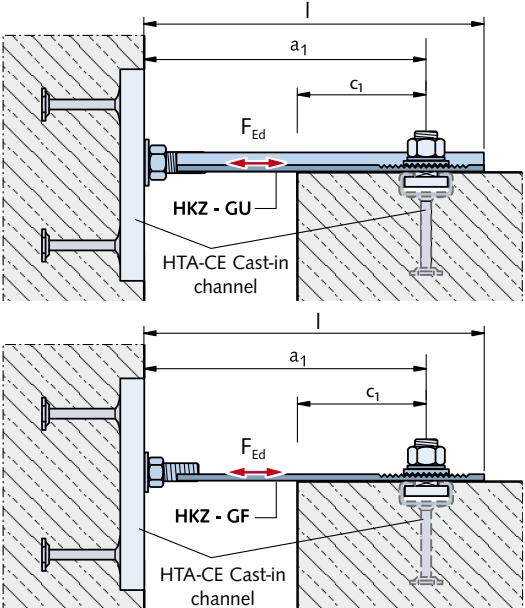

Product description

The serrations in the bracket and in the washer ensure positive static load transmission.

⚠ Please order HALFEN Cast-in channels and HALFEN Bolts and washers separately.

The double-sided attachment using a HALFEN Bolt and a threaded plate ensures positive and slippage-free wind anchoring when used in combination with HALFEN HTA-CE Cast-in channels set in concrete; connection is three-dimensionally adjustable.

Ordering example:

Item name: **HKZ - GF 38/17 - 125 - GV**
 type ———
 axial spacing a_1 ———
 material/ GV/A4 ———

HALFEN Restraint ties type HKZ-GF and type HKZ-GU								
Characteristics:	Type selection:		Type selection:		Dimensions:			
	Type	a_1	Type	a_1	Length l	Spacing a_1	Tolerance	
① Load capacity F_{Rd} [kN]	GV = galvanized not suitable for façades with ventilation gap		A4 = Stainless steel 1.4571/1.4404				Slot	
	Type	a_1 [mm]	Type	a_1 [mm]	[mm]	[mm]	[mm]	
±4.9	HKZ - GF 28/15 - 75 - GV		HKZ - GF 28/15 - 75 - A4		115	75	$a_1 \pm 20$	11 x 55
	HKZ - GF 28/15 - 100 - GV		HKZ - GF 28/15 - 100 - A4		140	100		
	HKZ - GF 28/15 - 125 - GV		HKZ - GF 28/15 - 125 - A4		165	125		
	HKZ - GF 28/15 - 150 - GV		HKZ - GF 28/15 - 150 - A4		190	150		
	HKZ - GF 28/15 - 175 - GV		HKZ - GF 28/15 - 175 - A4		215	175		
±9.8	HKZ - GF 38/17 - 100 - GV		HKZ - GF 38/17 - 100 - A4		140	100	$a_1 \pm 20$	13 x 55
	HKZ - GF 38/17 - 125 - GV		HKZ - GF 38/17 - 125 - A4		165	125		
	HKZ - GF 38/17 - 150 - GV		HKZ - GF 38/17 - 150 - A4		190	150		
	HKZ - GF 38/17 - 175 - GV		HKZ - GF 38/17 - 175 - A4		215	175	$a_1 \pm 20$	13 x 55
	HKZ - GU 38/17 - 200 - GV		HKZ - GU 38/17 - 200 - A4		240	200		
	HKZ - GU 38/17 - 225 - GV		HKZ - GU 38/17 - 225 - A4		265	225		
	HKZ - GU 38/17 - 250 - GV		HKZ - GU 38/17 - 250 - A4		290	250		
±16.8	HKZ - GU 50/30 - 200 - GV		HKZ - GU 50/30 - 200 - A4		240	200	$a_1 \pm 20$	17 x 60
	HKZ - GU 50/30 - 225 - GV		HKZ - GU 50/30 - 225 - A4		265	225		
	HKZ - GU 50/30 - 250 - GV		HKZ - GU 50/30 - 250 - A4		290	250		
	HKZ - GU 50/30 - 275 - GV		HKZ - GU 50/30 - 275 - A4		315	275		
	HKZ - GU 50/30 - 300 - GV		HKZ - GU 50/30 - 300 - A4		340	300		

① The load capacities apply for the HKZ-restraint ties. The channels A and the fixings B must be verified case by case, depending on the concrete strength, the reinforcements and the edge distance c_1 .

ROOF & WALL

Precast Connection HVL

Assembly:

The connecting strap is delivered ready to be installed: The screw fastening sets and the counter plate are pre-assembled for fast installation.

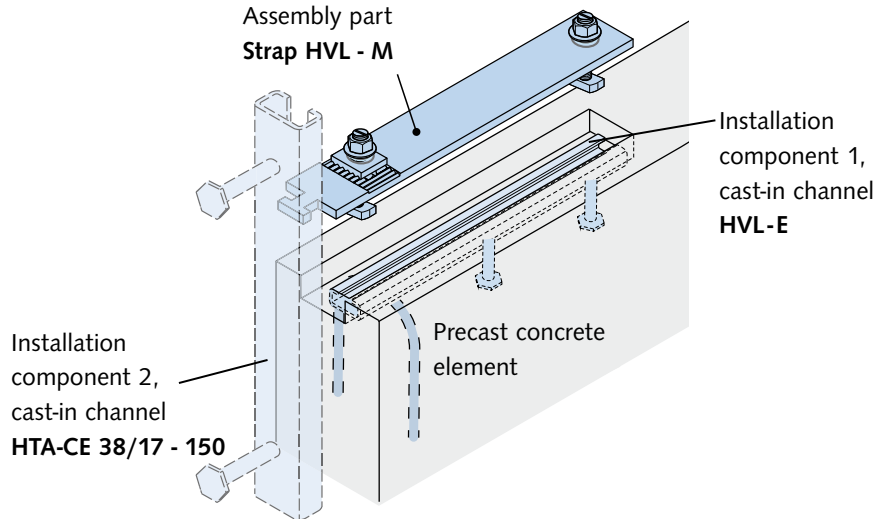
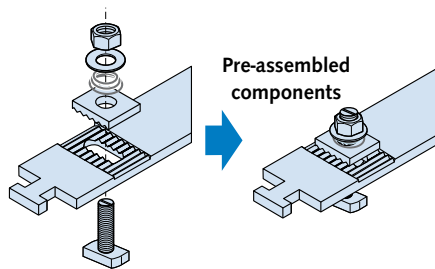

Assembly part HVL-M

Pre-assembled, consisting of:

- serrated hammer-head strap
- 1 serrated counter plate
- 2 bolt sets
(Bolt HS 38/17 - M12 x 50+ washer + tapered compressed spring)

Installation component 1 HVL-E:

HALFEN Cast-in channel HTA 38/17-300-SK with 2 bolt anchors and one loop end anchor.

Installation component 2:

HALFEN Cast-in channel HTA-CE 38/17-150 with 2 bolt anchors.

Corrosion protection

- hammer-head strap, cast-in channel: hot-dip galvanized
- HALFEN Bolts, nuts, washers and springs: galvanized

These parts are covered by mortar after installation.

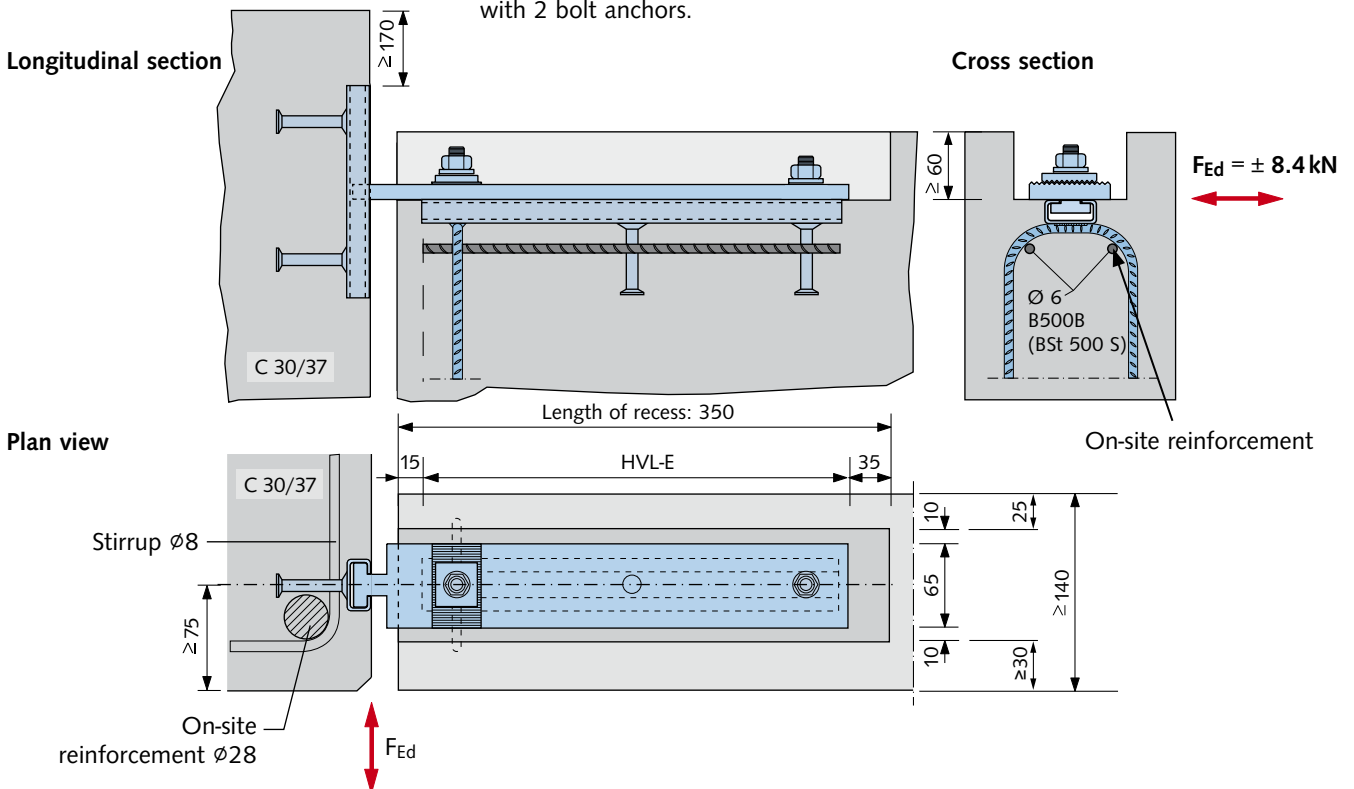

ROOF & WALL

HALFEN HKW Corner Guard

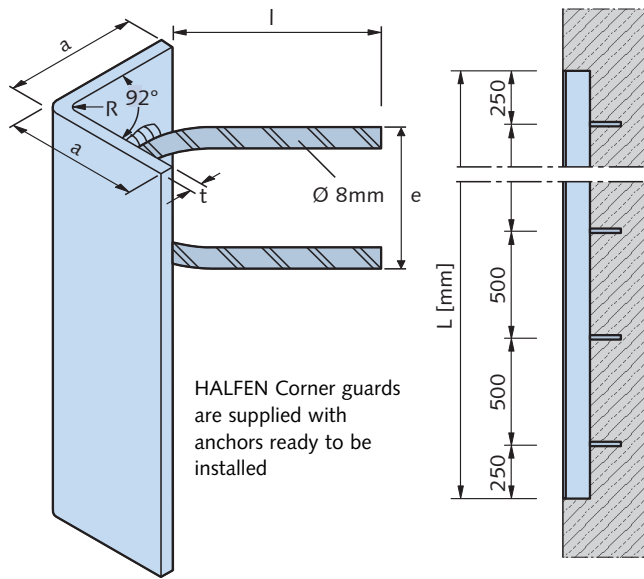

Column edge, typical cross-section

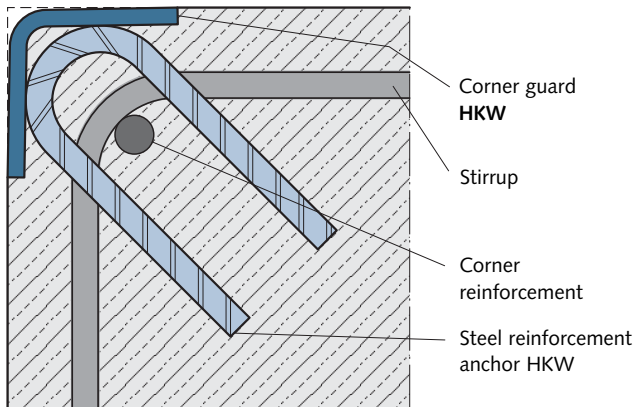

Corner guard HKW						
Type selection:		Material/Finish:		Anchor dimensions	Radius	
Type	Length L [mm]	no. of anchors	FV = hot-dip galvanized	A2 = Stainless steel	R [mm]	
a/t [mm]			■	□		
HKW 50/5 -	500	2	FV	A2	75 x 55	6
	750	2	FV	A2		
	1000	2	FV	A2		
	1500	3	FV	A2		
	2000	4	FV	A2		
HKW 80/6 -	500	2	FV	A2	100 x 85	8
	750	2	FV	A2		
	1000	2	FV	A2		
	1500	3	FV	A2		
	2000	4	FV	A2		
HKW 100/8 -	500	2	FV	A2	110 x 85	16
	750	2	FV	A2		
	1000	2	FV	A2		
	2000	4	FV	A2		

Material/Finish:

- **FV** = **Corner profile:** Steel hot-dip galvanized 1.0038
Anchor: B500B (BSt 500 S)
- **A2** = **Corner profile:** Stainless steel 1.4307
Anchor: B500B/A NR

Ordering example:

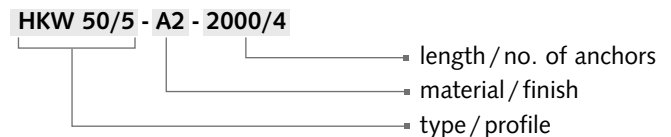

Advantages:

- 92° angle ensures a tight fit to the formwork. This prevents concrete seeping between the formwork and the corner profile, resulting in a smoother finish
- U-shaped concrete reinforced anchors do not interfere with the corner reinforcement and allow easy installation of the reinforcement
- anchors are of reinforcement steel quality to guarantee optimal anchorage
- competitive pricing through serial production

Curtain Wall HCW

The advantages at a glance

Todays modern buildings require façades of the highest quality that can be installed quickly and safely. This is the reason the Curtain Wall System is chosen more and more frequently by architects and investors.

Fast and cost-effective

- 3-dimensional adjustable connection when used with anchor channels
- uses bolts instead of welds
- fast assembly reduces installation time

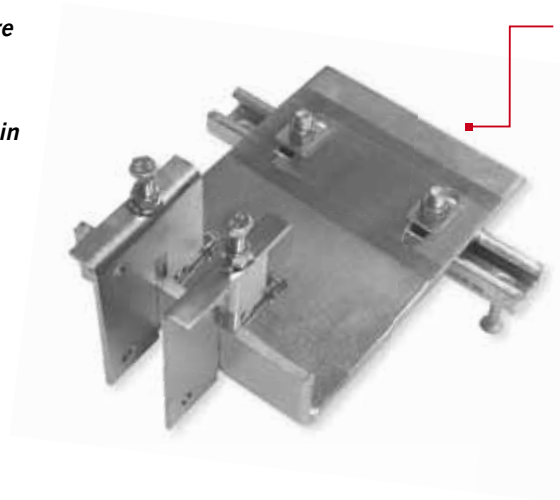

HCW B2

For modular façades.
Anchored to the top surface of floor slabs.

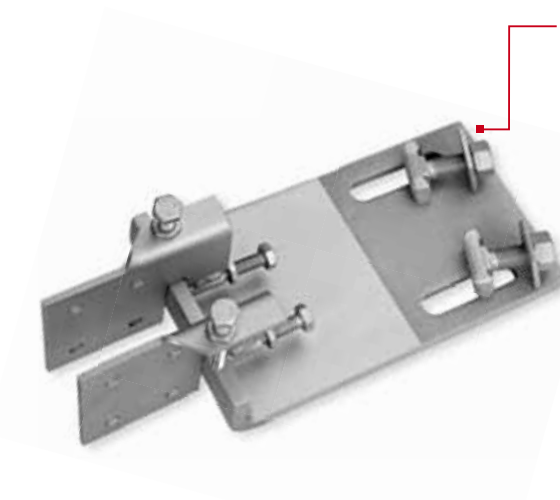

HCW B1

For post and beam façades.
Anchored to the top surface of floor slabs.

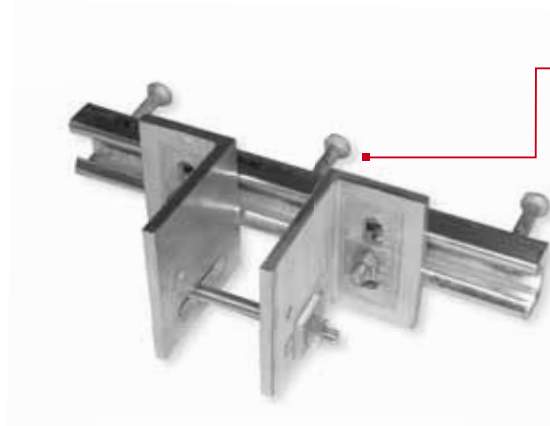

HCW- ED/EW

For post and beam façades.
Anchored to the front surface of floor slabs.

HALFEN CURTAIN WALL SUPPORT SYSTEMS HCW

Application Examples

1
HTA-CE Channels



Fixing of curtain wall system using HCW-B2 Brackets connected to HTA-CE Anchor channels

2
HZA Channels



Liberty Life, Johannesburg



Torre Espacio, Madrid

3
HGB Channels



Fixing of a post and beam façade using HCW-ED Brackets on HTA-CE Channels



Post Tower, Bonn



Sage Centre, Gateshead

4
HTU Channels



Fixing of a modular façade using HCW-ED Brackets on HTA-CE Channels



Burj Khalifa, Dubai



Edificio Gas Natural, Barcelona

5
Roof and Wall

6
Curtain Wall

7
Accessories



Typical curtain wall fixing with HTA-CE Anchor channels



Westin Libertador Hotel, Lima



World Financial Center, Shanghai

HALFEN CURTAIN WALL SUPPORT SYSTEMS HCW

General

HALFEN Curtain wall system

This type of construction is characterized by an outer wall with a continual outer skin (see figure 1).

The façade is attached to the main structure of the building using only the required number of point-load connections.

Curtain wall façades protect the interior of buildings from external, unwanted environmental influences whilst still

permitting visual contact with the outside environment with structural components that can be opened or are transparent. Specifically, this includes sufficient stability against wind loads, adequate insulation against frost in winter, heat in summer as well as against external noise.

In addition, various requirements must be met to protect against fire and other critical situations.

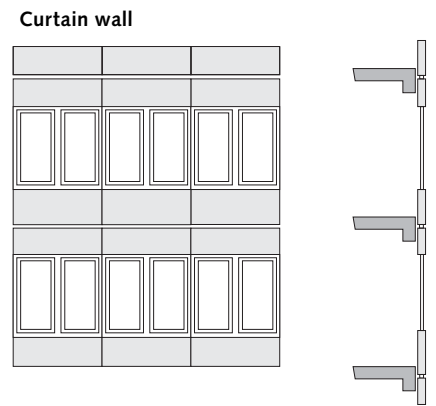

Figure 1 partial view of a façade

section

Post and beam façade and the modular façade

Basically, we distinguish between two methods of curtain wall façades constructions: the **post and beam façade** and the **modular façade**.

Post and beam façade

One basic distinctive difference is the way expansion in the façade is distributed (for example; thermal expansion). With the post and beam façade (see figure 2) the vertical and horizontal frame supports are installed in spacings corresponding to the façade elements. The supports are installed with an expansion gap between components allowing for sufficient expansion.

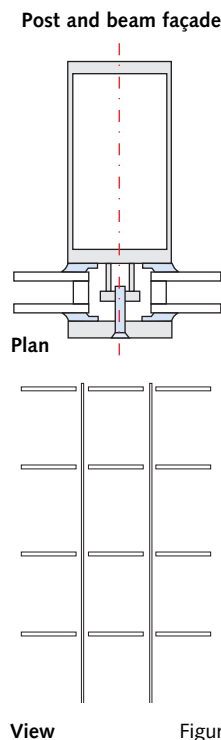

View Figure 2

The respective longitudinal and transverse connections have an expandable joint. The filler elements (glass or panel) installed in a post and beam structure permit movement within the tolerance of the designed expansion joint. The glass and filler elements are delivered separately and are then installed on site, requiring on-site scaffolding.

Modular façade

With the modular façade method (see figure 3), the façade is made of prefabricated elements, in which glass, natural stone or infills are pre-installed. The façade profiles are designed as a key and slot system to allow for expansion.

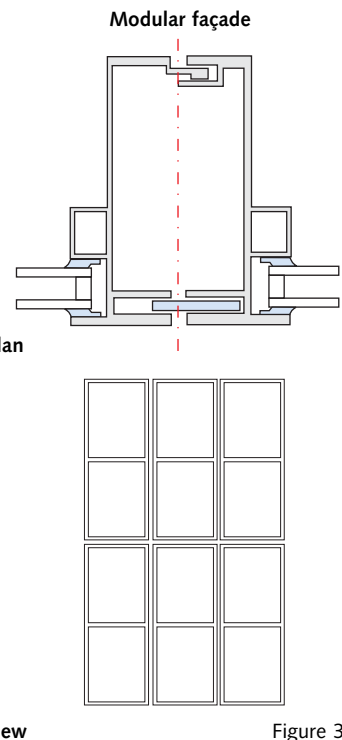

View Figure 3

This method provides immediate weather protection and allows the building contractor to start interior work on the respective floor directly after the prefabricated modules have been installed. Scaffolding is not required with this method of construction.

HALFEN CURTAIN WALL SUPPORT SYSTEMS

Product Range

1 Load conditions and required HALFEN Cast-in channels

Standard slab thickness
with standard tensile and transverse tensile loads
 HALFEN Channels with bolt anchors and weld-on I-anchors

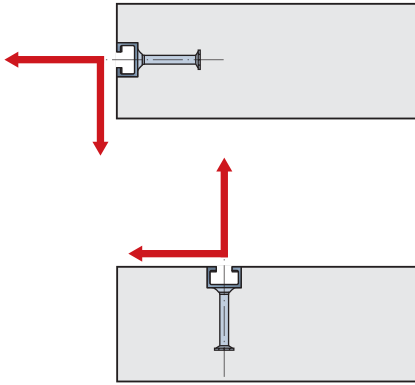

see pages 16–17, 31

Hot-rolled serrated channels and bolts

HZS 29/20 M12 HZS 38/23 M12, M16 HZS 53/34 M16, M20 HZS 64/44 M20, M24

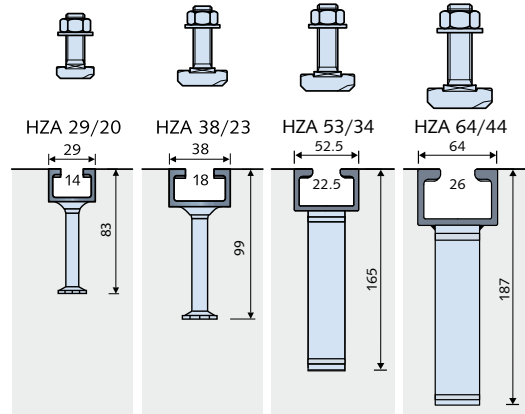

Thin slabs (thickness ≥ 12.5 cm)
with high transverse tensile loads
and small edge distance
 HALFEN Curtain wall channel
 HCW 52/34
 (not included in the HTA-CE approval)

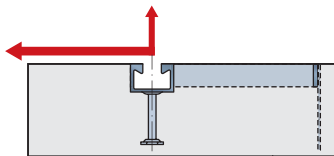

see pages 76–77

HCW 52/34 and bolt

HS 50/30, M16, M20
 Grade 8.8

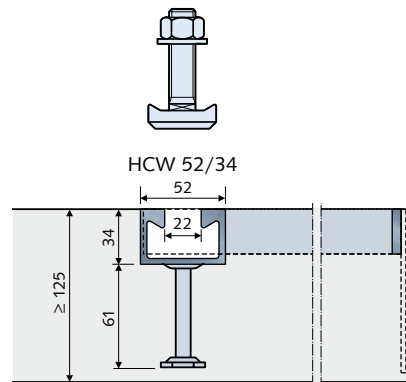

Thin slabs (thickness ≥ 10 cm)
with high tension loads
 HALFEN Channels HTA-R or HZA-R
 with rebar anchors
 (not included in the HTA-CE and
 HZA approvals)

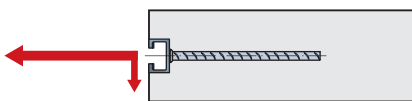

see page 78

Hot-rolled serrated channels with rebar anchors and bolts

HZS/HS 29/20 M10 / M12 HZS/HS 38/23 M12 / M16 HZS 53/34 M16 / M20

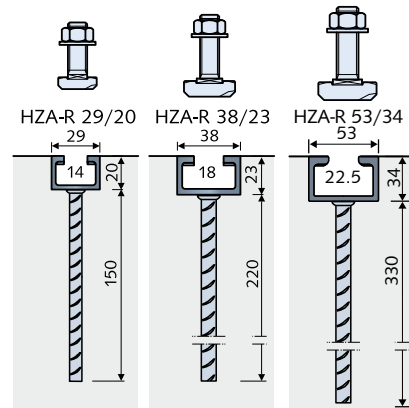

HALFEN CURTAIN WALL SUPPORT SYSTEMS

Product Range

Load cases and required HALFEN Channels

Hot-rolled (standard) channels and bolts

HS, HSR 40/22
M12, M16

HS 50/30, M12, M16, M20
HSR 50/30, M20

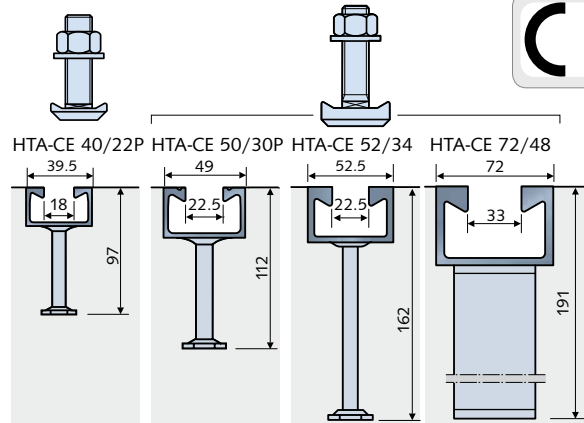

⚠ HSR Bolt according to expert reports

Cold-rolled (standard) channels and bolts

HS 38/17
M12, M16

HS 40/22
M12, M16

HS 50/30
M12, M16, M20

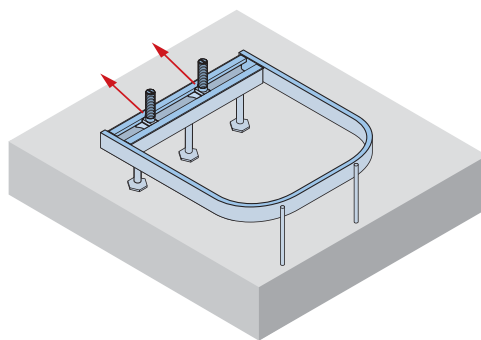
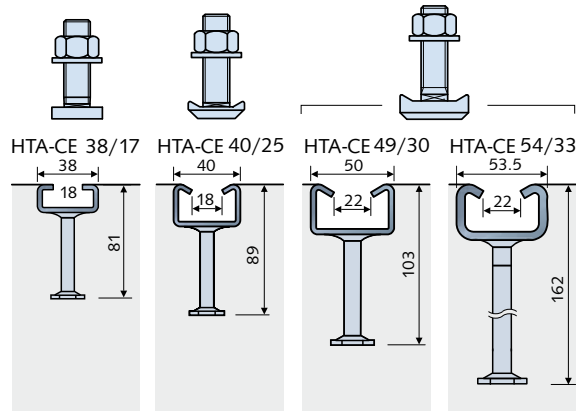

HCW 52/34 with bolts and bracket

Hot-rolled (smooth) channels with rebar anchors and bolts

HS 40/22
M12, M16

HS 50/30
M12, M16, M20

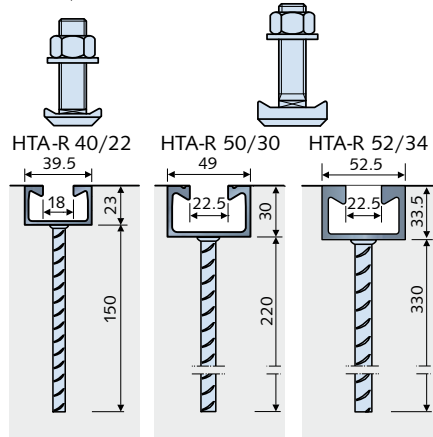

Cold-rolled (smooth) channels with rebar anchors and bolts

HS 38/17
M12, M16

HS 40/22
M12, M16

HS 50/30
M12, M16, M20

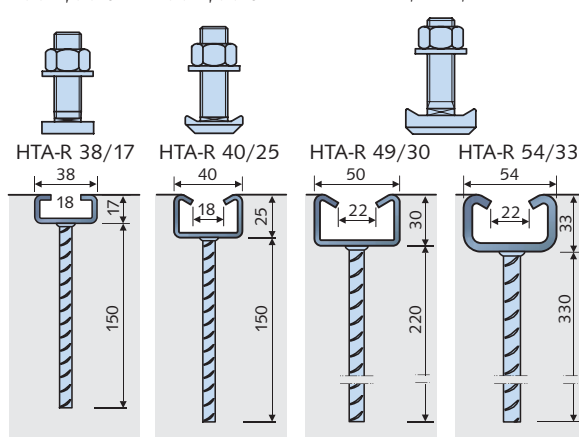

1 HTA-CE Channels
2 HZA Channels
3 HGB Channels
4 HTU Channels
5 Roof and Wall
6 Curtain Wall
7 Accessories

HALFEN CURTAIN WALL SUPPORT SYSTEMS

HALFEN Cast-in Channel HCW 52/34

Channel load data

The following load failure were averaged from three tests:

F_V failure	=	142.3 kN
F_N failure	=	47.4 kN
$F_{res, failure}$	=	$\sqrt{F_N^2 + F_V^2}$ = 150.0 kN

The load deformation diagram (see right) may be used to determine allowable loads based on acceptable displacement and the required safety factor according to local building codes. The diagram is based on the following:

- tensile and transverse loads were increased at a ratio of 1:3 up to breaking point
- concrete slab thickness ≥ 125 mm and reinforcement as shown on page 76
- concrete strength class $\geq C 20/25$ N/mm²
- load is transferred into the channel via two HALFEN Bolts HS 50/30 M20 Grade 8.8. The bolt spacing is 150 mm. A sample calculation is shown below.

The safety factor is freely selected. However, it must be determined which factors are actually to be implemented, whether these are based on project specific boundary condition or on valid building regulations.

Calculation example: Assumed safety factor $v = 3$
(failure test load / working load)

Average failure load from the tests:

Transverse tensile stress	F_V ultimate	=	142.3 kN
Tensile stress	F_N ultimate	=	47.4 kN
Res. diagonal tensile load	$F_{res, ultimate}$	=	150.0 kN

Actual working loads at bolts (specification by façade stress engineer):

Transverse tensile stress	$F_V = 35$ kN
Tensile stress	$F_N = 10$ kN

Allowable load with $v = 3$ against average ultimate load from tests:

perm. F_V	=	$142.3 / 3$	=	47.4 kN
perm. F_N	=	$47.4 / 3$	=	15.8 kN
perm. F_{res}	=	$150 / 3$	=	50.0 kN

Control: Working load F_V	=	35 kN < 47.4 kN
Working load F_N	=	10 kN < 15.8 kN
Working load F_{res}	=	$\sqrt{(10)^2 + (35)^2} = 36.4$ kN < 50 kN

Displacement at working load < 1 mm (see diagram).

Actual safety factor for average ultimate load $\gamma_1 = (150 / 36.4) = 4.12$.

Load deformation diagram

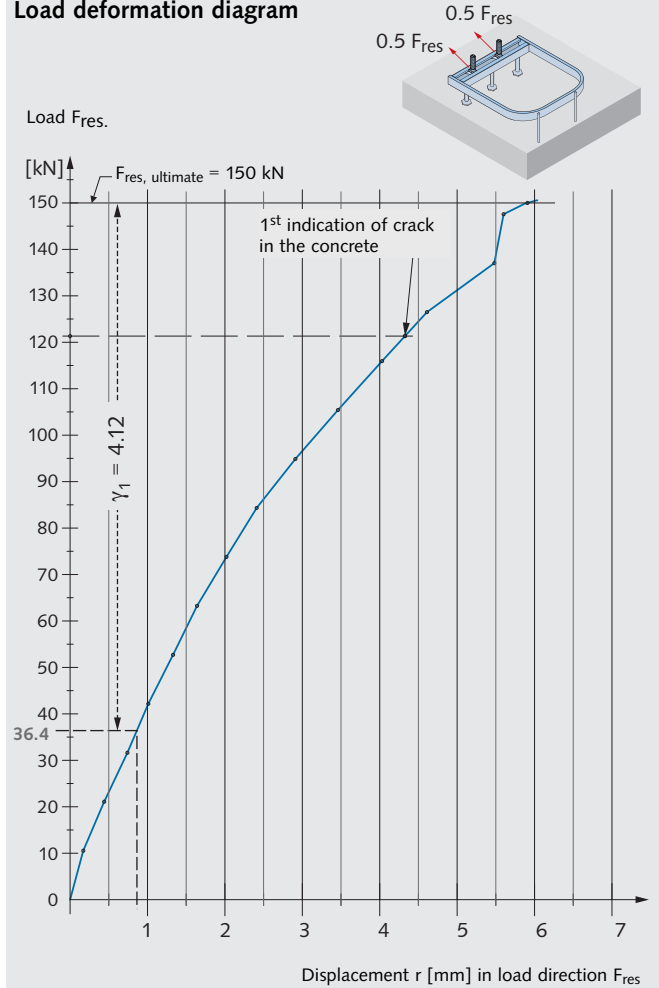

Corresponding HALFEN Bolts HS 50/30

Depending on the load size, we recommend the use of HALFEN Bolts HS 50/30 M16 or M20, grade 8.8 in combination with HALFEN Cast-in channel HCW 52/34. The bolts stated below are zinc galvanized with a special coating.

For interior use this design is considered equivalent to a hot-dip galvanized design. Other bolt sizes and materials can be supplied. Please contact us for detailed information. Addresses can be found on page 91.

Type selection HALFEN Bolts HS 50/30 GV Grade 8.8

Thread	Material grade	Available length L [mm]	Allowable resulting bolt load (all directions) perm. F_s [kN]	Allowable bending moment [Nm]	Recommended torque [Nm]	If the bolt is stressed in the direction of a slot its load capacity must be verified taking bolt flexure into account.
M 16	8.8	40, 60, 80, 100	36.1	111	60	
M 20	8.8	45, 60, 80, 100	56.4	216	120	

HALFEN CURTAIN WALL SUPPORT SYSTEMS

HALFEN Cast-in Channels with Rebar Anchor HTA-R and HZA-R

Design basics

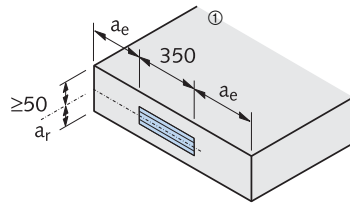
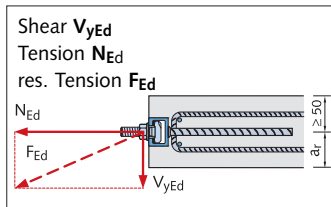

① The minimum edge distance shown in the table applies to reinforced concrete

Structural analysis

	Material resistance		Design load
Material resistance shear	V_{yRd}	\geq	V_{yEd}
Material resistance tension	N_{Rd}	\geq	N_{Ed}
Material resistance resulting diagonal pull	F_{Rd}	\geq	$F_{Ed} = \sqrt{N_{Ed}^2 + V_{y,Ed}^2}$

HALFEN Cast-in channels HTA-R and HZA-R - Material design resistance values

HALFEN Cast-in channel type	HTA-R 38/17 ②	HTA-R 40/25 ② HTA-R 40/22 ② HZA-R 29/20 ③	HTA-R 49/30 ② HTA-R 50/30 ② HZA-R 38/23 ③	HTA-R 54/33 ③ HTA-R 52/34 ② HZA-R 53/34 ③
Concrete strength grade \geq C20/25 $f_{ck,cyl.} = 20 \text{ N/mm}^2$ $f_{ck,cube} = 25 \text{ N/mm}^2$	350 mm 3 anchors	350 mm 3 anchors	350 mm 3 anchors	350 mm 3 anchors
$F_{Rd} = N_{Rd}$ [kN]	2×7.0	2×9.1	2×14.0	2×24.5
a_r [mm]	≥ 50	≥ 60	≥ 70	≥ 75
a_e [mm]	≥ 40	≥ 45	≥ 50	≥ 50
V_{yRd} [kN]	2×2.4	2×3.7	2×4.9	2×5.6
Material: hot-dip galvanized	Channel	1.0038, 1.0044	Anchor	B500B (BSt 500S)
Material: stainless steel	Channel	1.4571 / 1.4404 ④	Anchor	B500B (BSt 500S)

② Material 1.0038, ③ Material 1.0044, ④ Not available for HALFEN Cast-in channels HZA-R 29/20
Notes: HALFEN Cast-in channels HTA-R / HZA-R are not included in the HTA-CE / HZA-Approval

Other channel lengths from 150 – 6070 mm are available

HALFEN CURTAIN WALL SUPPORT SYSTEMS

Edge of Slab Brackets HCW-ED Post and Beam Façades

Application example

HALFEN Edge of slab brackets are connected in pairs, one each side of the mullion, and are available in two types:

Type HCW-ED Brackets are designed to support both **vertical and horizontal** loads.

Type HCW-EW Brackets are designed to support **horizontal** wind loads only.

The brackets guarantee a simple adjustable connection. The HALFEN Bolts (connection: bracket to HALFEN Channel) and the standard hexagonal bolts M12 (connection: bracket to façade mullion) must be grade strength 8.8. A round auxiliary hole in the long arm of the brackets can be used for temporary attachments; example: temporary fixing of brackets to support post with self-tapping screws until the final connection is made.

The brackets are made of high quality aluminium material. Special nylon discs are placed between the "Wind load" Bracket HCW-EW and support post.

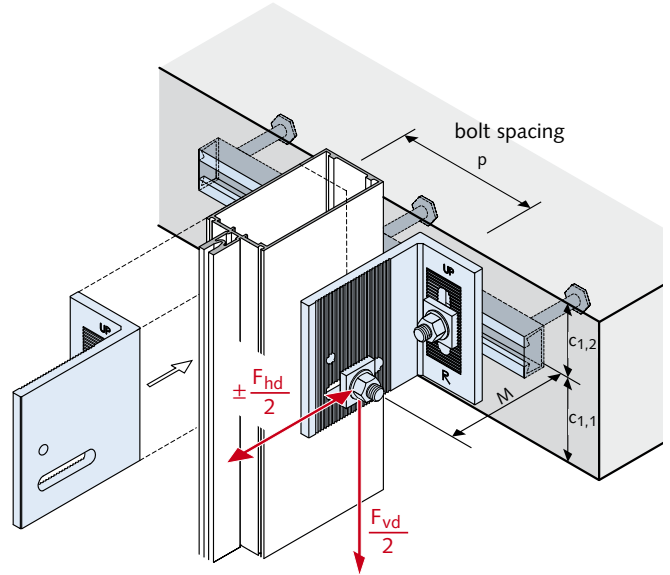

To guarantee correct installation, the HCW-ED brackets are marked 'R' for right, 'L' for left and 'UP' for top.

Bracket dimensions [mm]

HCW-ED Brackets
for dead loads
and wind loads

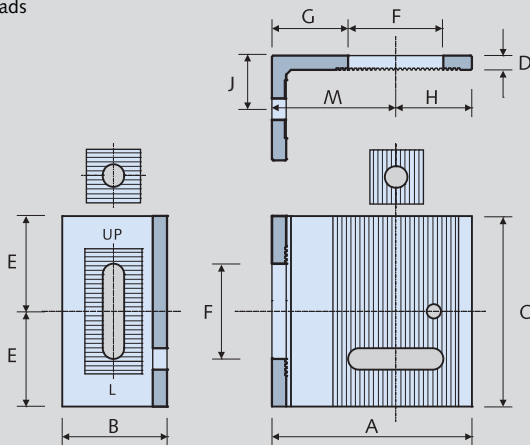

Serrated washers included in delivery

HCW-EW Brackets
wind loads only

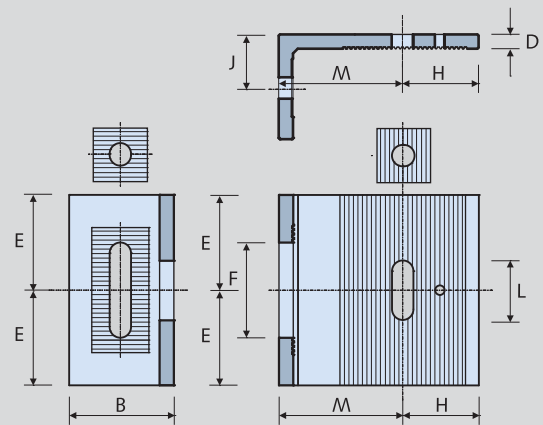

Serrated washers included in delivery

Size	Bracket code	A	B	C	D	E	F	G	H	J	L	M
Small	HCW-ED 1 HCW-EW 1	108	70	114	10	57	64	25	51	36	40	57
Medium	HCW-ED 2 HCW-EW 2	133	70	127	10	64	64	51	51	36	40	82
Large	HCW-ED 3 HCW-EW 3	159	70	140	10	70	64	76	51	36	40	108

HALFEN CURTAIN WALL SUPPORT SYSTEMS

Dimensioning

1 Interaction diagram for type HCW-ED1 (small)

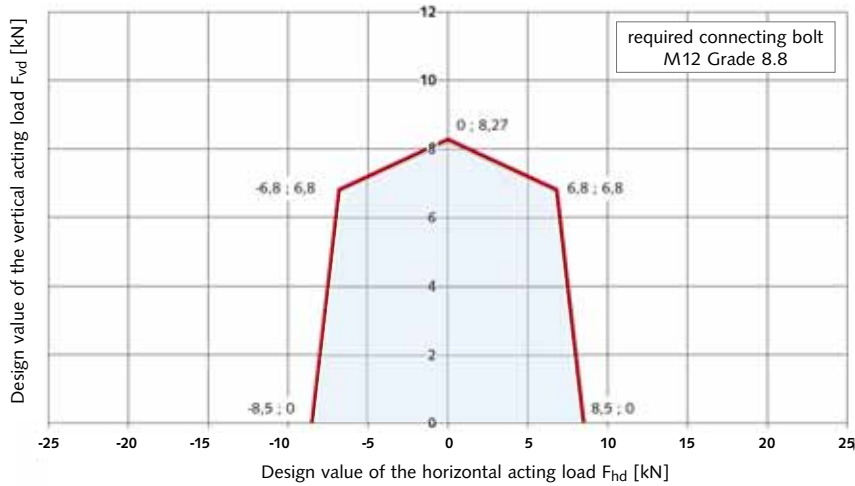

2 Interaction diagram for type HCW-ED2 (medium)

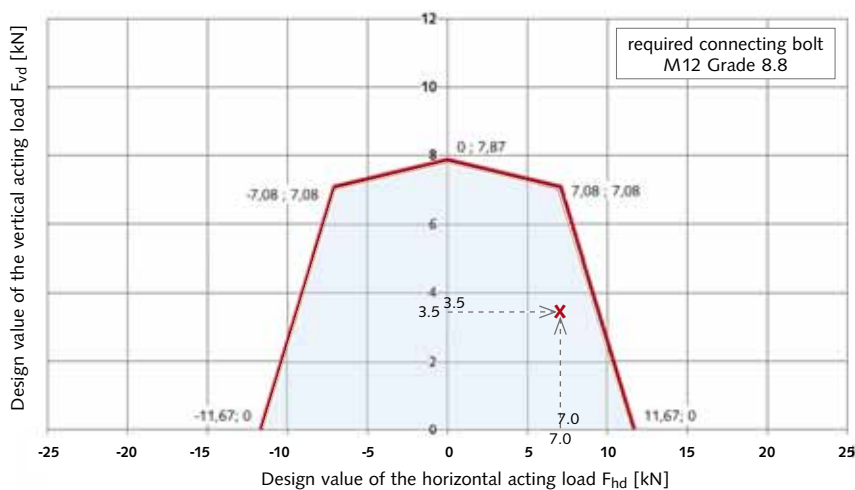

3 Interaction diagram for type HCW-ED3 (large)

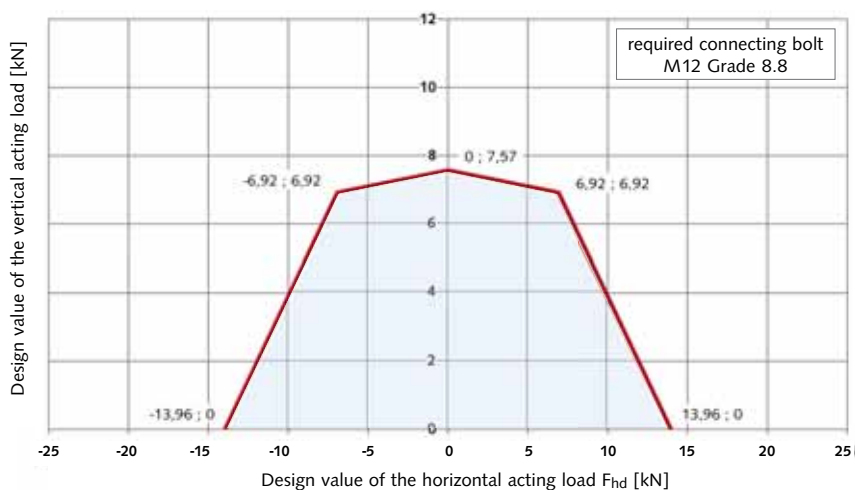

Calculation basis

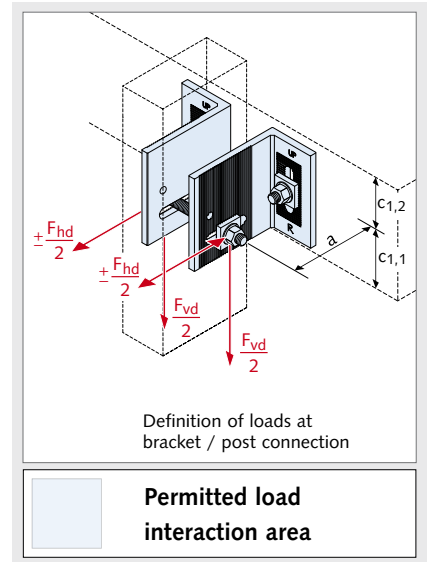

HALFEN CURTAIN WALL SUPPORT SYSTEMS

Design Loads using two HCW-EW Brackets, Loads in the HALFEN Bolts (HCW-ED)

Design wind loads for type HCW-EW

Max. applied design load F_{hd} [kN]			
Size	Bracket code	max. F_{vd} [kN]	max. F_{hd} [kN]
Small	HCW-EW 1	0	8.5
Medium	HCW-EW 2	0	11.67
Large	HCW-EW 3	0	13.96

HCW-EW Brackets are only suitable for wind loads.

Forces acting on the T-head bolts at the channel (HCW-ED)

The design reaction forces components in the HALFEN Bolts at connection curtain wall bracket to HALFEN Cast-in channel are calculated by multiplying the design loads F_{vd} and F_{hd} at connection curtain wall bracket and façade support post with the factors s_x , s_y and s_z .

The factors are dependent on the bracket geometry, the load direction and the bolt position (see figure on the right). See table below for the multiplication factors for determining the design reaction forces in the HALFEN Bolts.

Lower installation position of HALFEN Bolt (Position 3)

Bracket	Dead load $S_i = (F_{vd} / 2) \times s_i$			Wind load $S_i = (F_{hd} / 2) \times s_i$			Resulting load 45° $S_i = (\text{res. } F_d / 2) \times s_i$		
	s_x	s_y	s_z	s_x	s_y	s_z	s_x	s_y	s_z
HCW-ED 1	0.5	3.2	-1.0	-1.0	1.0	0.0	-0.3	3.0	-0.7
HCW-ED 2	0.5	3.6	-1.0	-0.5	1.0	0.0	0.0	3.3	-0.7
HCW-ED 3	0.5	4.0	-1.0	-0.4	1.0	0.0	0.1	3.5	-0.7

Upper installation position of HALFEN Bolt (Position 1)

HCW-ED 1	0.6	1.3	-1.0	-1.0	3.6	0.0	-0.3	3.4	-0.7
HCW-ED 2	0.6	1.6	-1.0	-0.5	3.1	0.0	0.0	3.4	-0.7
HCW-ED 3	0.6	1.9	-1.0	-0.4	2.9	0.0	0.1	3.4	-0.7

Calculation basis

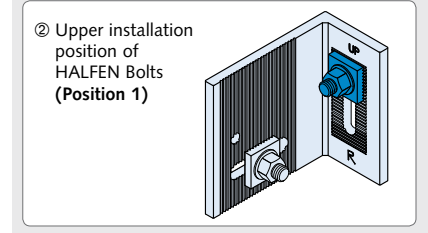
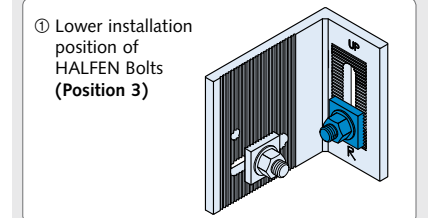
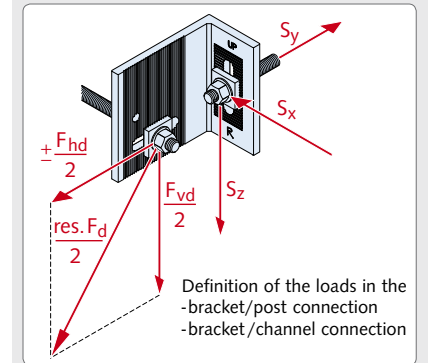

Calculation example

Assumed: slab thickness = 200 mm, width of mullion = 80 mm, projection a = 80 mm (install. position see page 79)
 design dead load $F_{vd} = +3.5$ kN
 design wind load (wind suction) $F_{hd} = +7.0$ kN

Selected: HALFEN Bracket type HCW-ED 2
 ⇒ possible projection $M = 82 \pm 25$ mm
 ⇒ Interaction diagram type HCW-ED 2 (see page 80) proves that the assumed load is within the permitted load interaction zone

Determination of the design reaction forces in a HALFEN Bolt

① Lower installation position (Position 3)

$$\begin{aligned} S_x &= (3.5/2) \times 0.5 + (7/2) \times (-0.5) = -0.88 \text{ kN} \\ S_y &= (3.5/2) \times 3.6 + (7/2) \times 1.0 = +9.80 \text{ kN} \\ S_z &= (3.5/2) \times (-1.0) + 0 = -1.75 \text{ kN} \end{aligned}$$

⇒ Resulting bolt load

$$\text{res. } S_d = \sqrt{(-0.88)^2 + (9.80)^2 + (-1.75)^2} = 9.99 \text{ kN per bolt}$$

② Upper installation position (Position 1)

$$\begin{aligned} S_x &= (3.5/2) \times 0.6 + (7/2) \times (-0.5) = -0.70 \text{ kN} \\ S_y &= (3.5/2) \times 1.6 + (7/2) \times 3.1 = +13.65 \text{ kN} \\ S_z &= (3.5/2) \times (-1.0) + 0 = -1.75 \text{ kN} \end{aligned}$$

⇒ Resulting bolt load

$$\text{res. } S_d = \sqrt{(-0.70)^2 + (13.65)^2 + (-1.75)^2} = 13.78 \text{ kN} \rightarrow \text{each bolt} \rightarrow \text{determining factor for bolt selection}$$

Selected HALFEN Channel:

HTA-R 50/30 - 350 - 3 Anchor - FV see page 78

with $V_{yRd} = 2 \times 5.6 \text{ kN} > 2 \times |S_z| = 2 \times 1.75$
 ($a_r \geq 75$ mm)

$$F_{Rd} = 2 \times 14.0 \text{ kN} > 2 \times \text{res. } S_d = 2 \times 13.78 \text{ kN}$$

Check: bolt spacing: $P = 80 + 2 \times 36 = 152$ mm

> 150 mm ✓

Selected HALFEN Channel:

HS 50/30 - M12 × 60 GV 8.8

Requirement according to interaction diagram see page 80

HALFEN CURTAIN WALL SUPPORT SYSTEMS

Top of Slab Brackets HCW-B1

Support brackets for horizontal and vertical loads

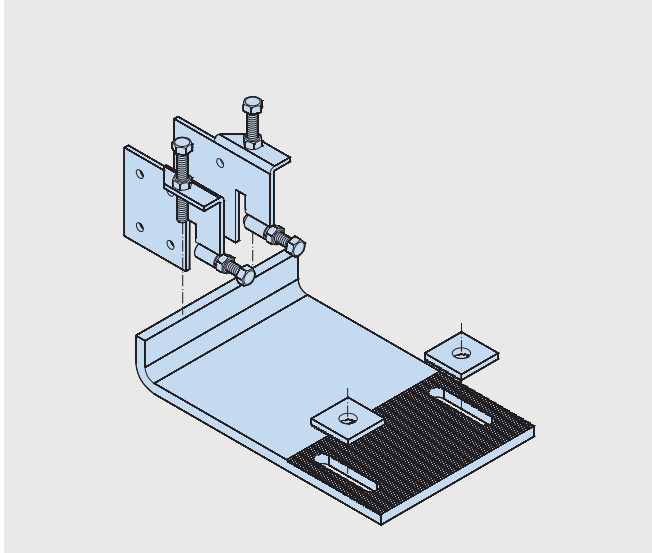

Typical installation

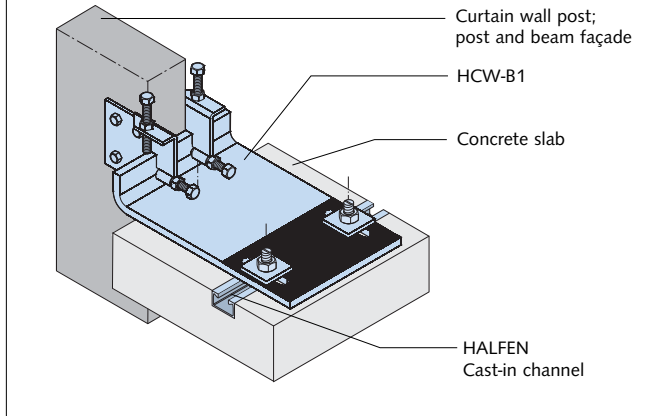

HALFEN Brackets HCW-B1

HALFEN Brackets HCW-B1 for installing in the top of concrete slabs, are available in two load ranges and three cantilever sizes.

The brackets are made in grade S355 quality galvanized steel. Vertical adjustability is ± 10 mm.

Three dimensional adjustability is ensured when used in combination with HALFEN HTA-CE in channels.

The lateral connecting plates are connected to the façade posts using M8 screws (not included). The façade planner is responsible for providing the static verification for the support posts. Use M16 HALFEN Bolts, grade 8.8 (order separately), to connect the base bracket to the HALFEN Cast-in channel. Depending on the façade type, the connection between the connecting plate and the base bracket can be designed either laterally adjustable or as a fixed point.

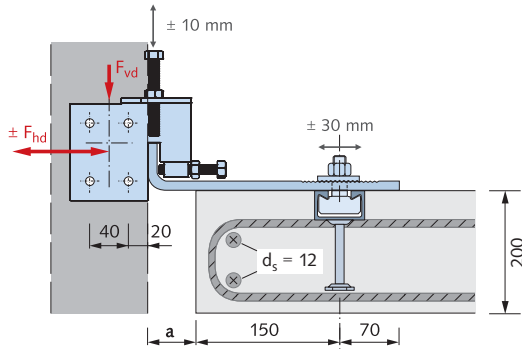

Section

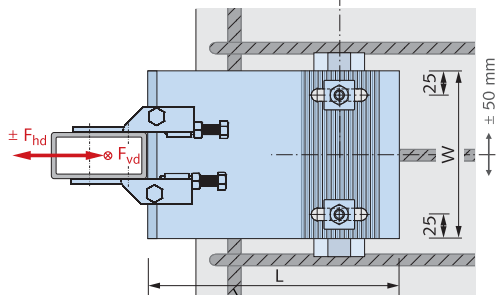

Plan

Required edge reinforcement $\geq \phi 12$ (B500B)

Dimensioning / Type selection

Design load ranges

Load range [kN]	dead load F_{vd} [kN]	wind load F_{hd} [kN] (wind suction + compression)
4/12	4	± 12
7/20	7	± 20

F_{vd} , F_{hd} : allowable design loads with a partial safety factor $\gamma_F = 1.35$ for dead load and $\gamma_F = 1.5$ for wind load.

Type selection

Load range [kN]	a [mm]	Item name HCW-B1-...	L [mm]	W [mm]	HALFEN Channel ①	Recommended HALFEN Bolt
4/12	50	...-4/12-50	270	150	HTA-CE 40/22P-250 2 Anchors	HS 40/22 M16×60 8.8
	75	...-4/12-75	295	150		
	100	...-4/12-100	320	150		
7/20	50	...-7/20-50	270	175	HTA-CE 50/30P-300 3 Anchors	HS 50/30 M16×60 8.8
	75	...-7/20-75	295	175		
	100	...-7/20-100	320	200		

① Recommended HALFEN Channel exploiting full load capacity of bracket

HALFEN CURTAIN WALL SUPPORT SYSTEMS

Top of Slab Brackets HCW-B2

Brackets for horizontal and vertical loads

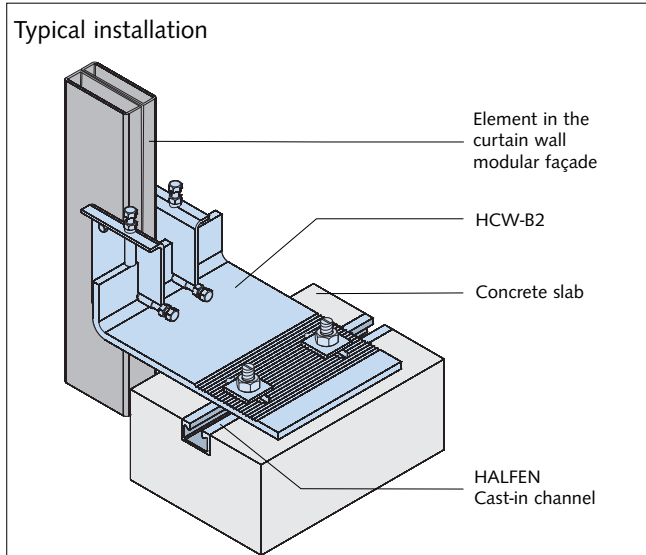
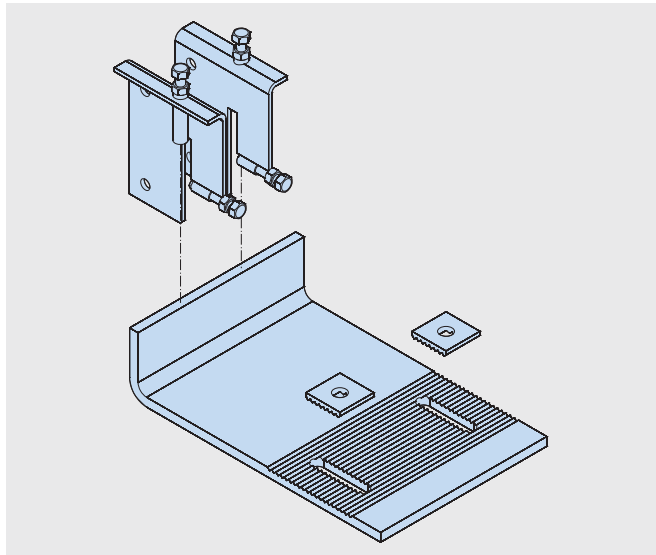

HALFEN Brackets HCW-B2

HALFEN Brackets HCW-B2 are made in grade S355 quality galvanized steel. The vertical adjustability is ± 24 mm. Three dimensional adjustability is ensured when used in combination with HALFEN Cast-in channels HTA-CE. The lateral connecting plates are connected to the façade posts using M12 screws (not included in delivery).

The façade planner is responsible for providing the static verification for the support posts. Use M16 HALFEN Bolts, grade 8.8 (order separately), to connect the base bracket to the HALFEN Cast-in channel. Depending on the façade type, the connection between the connecting plate and the base bracket can be designed either laterally adjustable or as a fixed point.

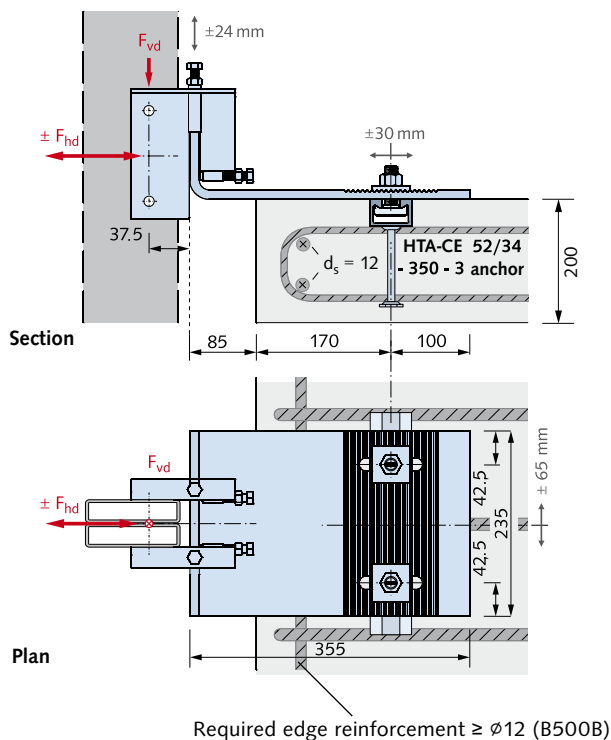

Dimensioning

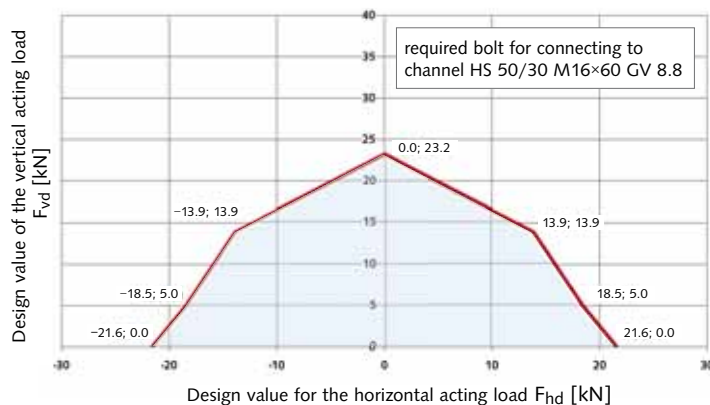

Allowable load interaction area

Accessories

The advantages at a glance

To complement the product range HALFEN offers a wide range of accessories. Everything from one source.

The product range

Everything you need from the framing channel right down to the nut, the locking washer, threaded rod, locking and threaded plate even an adjustable connector; we provide all you need for your project.

HALFEN Framing channels
You are guaranteed to find an economical solution for your projects in the extensive HALFEN Framing channels product range.

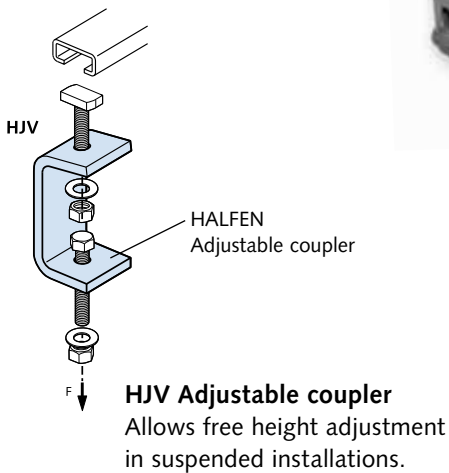
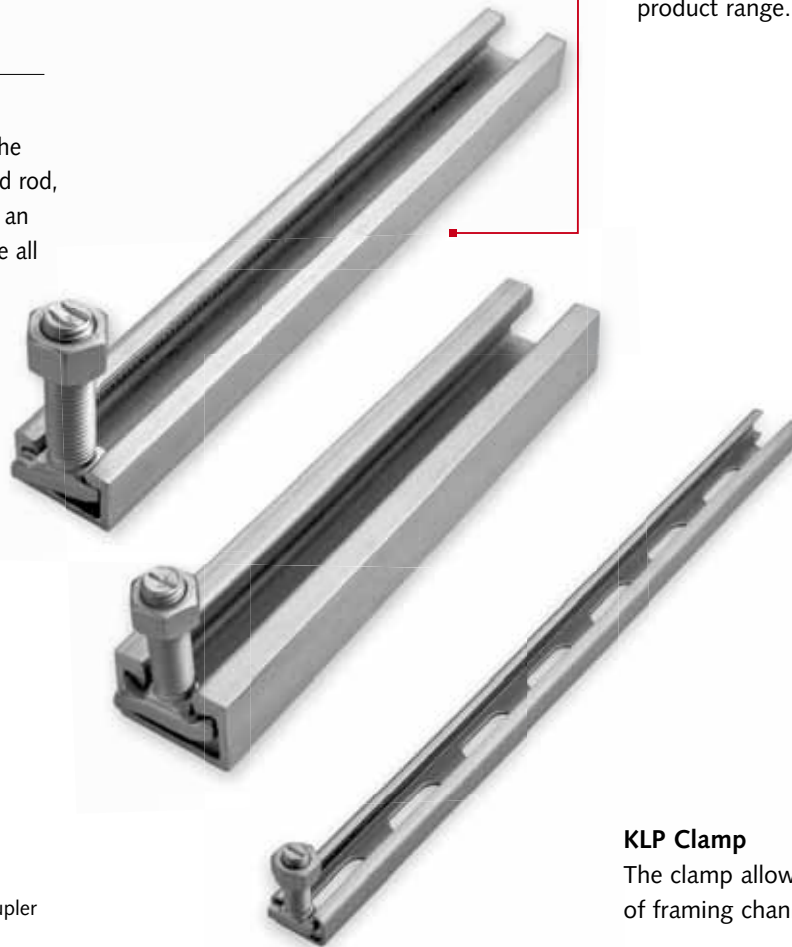

KLP Clamp

The clamp allows fast connection of framing channels to I-beams.

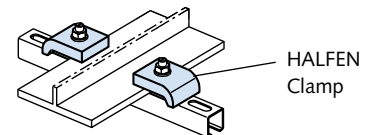

The whole range of framing system products can be found at www.halfen.de **MT-FBC** (Flexible bolt connections) or **MT-FFC** (Flexible framing connections).

ACCESSORIES

Nuts, Washers

Accessories: Nuts, Washers

MU

Hexagonal nuts
DIN EN
ISO 4032/
DIN 934

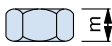
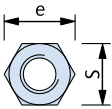

GV	A4	S/m	S/m	e
galvanized FK 8 thread	stainless steel thread	[mm]	[mm]	[mm]
M6	M6	10/ 5	10/ 6	11.5
M8	M8	13/6.5	13/7.5	15.0
M10	M10	17/ 8	16/9.5	19.6
M12	M12	19/10	18/12	21.9
M16	M16	24/13	24/15.5	27.7
M20	M20	30/16	30/19	34.6
M24	M24	36/19	36/22	41.5

FV	A2	S/m	S/m	e
hot-dip galvanized thread	stainless steel A2 thread	[mm]	[mm]	[mm]
M6, M8	M8	13/6.5	13/7.5	15.0
M10	M10	17/8	16/9.5	19.6
M12	M12	19/10	18/12	21.9
M16	M16	24/13	24/15.5	27.7

VUS

Square washers

VUS 40/25
for profile 40/25;
HZA 41/22

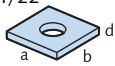

VUS 49/30
for profile 54/33,
49/30

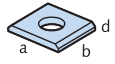

VUS 52/34
for profile 52/34,
50/30

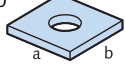

VUS 72/49
for profile 72/48,
72/49

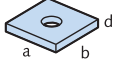

VUS 41/41
for all 41 profiles

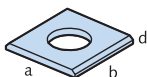

FV	A4	a × b × d
hot-dip galvanized for bolt	stainless steel for bolt	[mm]
M10	M10	40 × 40 × 5
M12	M12	40 × 40 × 5
M16	M16	40 × 40 × 5

FV	A2	D	d	s
hot-dip galvanized for bolt	stainless steel for bolt	[mm]	[mm]	[mm]
	M8	17	8.4	1.6
	M10	21	10.5	2
	M12	24	13	2.5
	M16	30	17	3

Ordering example: VUS 52/34 - FV - M20

Application VUS:

For shimming non-flush
installations

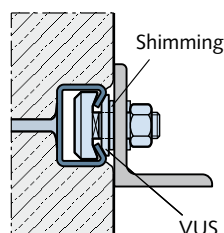

US

Washer
DIN 9021
DIN EN
ISO 7094/
DIN 440

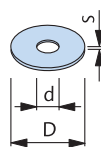

DIN	GV	A4	D	d	s
	galvanized for bolt	stainless steel for bolt	[mm]	[mm]	[mm]
440	M6		22	6.6	2
9021	M8	M8	24	8.4	2
9021	M10	M10	30	10.5	2.5
440	M12		45	13.5	4
9021	M12	M12	37	13	3
9021	M16	M16	50	17	3
440	M20		72	22	6

Ordering example: US - M12 - GV - DIN 9021

US

Washers
DIN EN ISO
7089/DIN 125

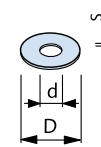

GV	A4	D	d	s
galvanized for bolt	stainless steel for bolt	[mm]	[mm]	[mm]
M6	M6	12	6.4	1.6
M8	M8	16	8.4	1.6
M10	M10	21	10.5	2
M12	M12	24	13	2.5
M16	M16	30	17	3
M20	M20	37	21	3
M24	M24	44	25	4

FV	A2	D	d	s
hot-dip galvanized for bolt	stainless steel for bolt	[mm]	[mm]	[mm]
	M8	17	8.4	1.6
	M10	21	10.5	2
	M12	24	13	2.5
	M16	30	17	3

Ordering example: US - M12 - GV - DIN 125

SIC

Locking washer

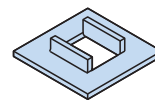

GV	A4	Suitable for HALFEN Bolts	
galvanized	stainless steel A4	type	dimensions
SIC - 50/30 - GV	SIC - 50/30 - A4	50/30	M16, M20
SIC - 40/22 - GV	SIC - 40/22 - A4	38/17 40/22	M16
SIC - 38/23 - GV		38/23	M16
SIC - 29/20 - GV		29/20	M12
SIC - 38/17 - GV	SIC - 38/17 - A4	38/17 40/22	M12, M10
SIC - 28/15 - GV	SIC - 28/15 - A4	28/15	M8, M10
SIC - 20/12 - GV	SIC - 20/12 - A4	20/12	M8

Ordering example: SIC - 38/17 - GV

Assembly scheme:

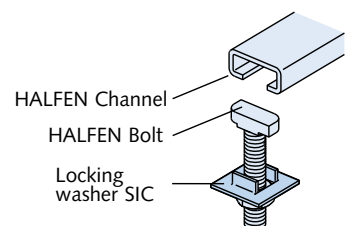

Application SIC:

For securing HALFEN Bolts;
prevents bolts turning when
tightening nuts

ACCESSORIES

Threaded Rods, Hex Bolts, Coupler Sleeves, Ring Nuts

Accessories: Threaded Rods, Hex Bolts, Coupler Sleeves, Ring Nuts

GWS

Threaded rods
DIN 976-1

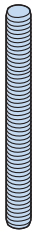

GV	A4	Length	F _{Rd}	perm. F
galvanized FK 4.6 thread	stainless steel thread	[mm]	① [kN]	[kN]
M6	M6	1000	3.1	2.2
M8	M8	1000	5.6	4.0
M10	M10	1000	9.0	6.4
M12	M12	1000	13.0	9.3
M16	M16	1000	24.2	17.3
M20	M20	1000	37.8	27.0
M24	M24	1000	54.3	38.8

Ordering example: GWS - M12 × 1000 - GV

VBM

Coupler sleeves,
round

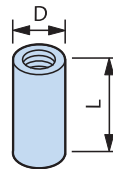

GV	A4	D	L	F _{Rd}	perm. F
hot-dip galvanized thread	stainless steel thread	[mm]	[mm]	① [kN]	[kN]
M6	M6	10/10	15	3.1	2.2
M8	M8	12/14	20	5.6	4.0
M10	M10	13/16	25	9.0	6.4
M12	M12	16/20	30	13.0	9.3
M16	M16	21/25	40	24.2	17.3
M20	M20	26/32	50	37.8	27.0

Ordering example: VBM - A4 - M16

HSK

Hexagonal
head bolts
DIN EN ISO 4017/
DIN 933
(without nut)

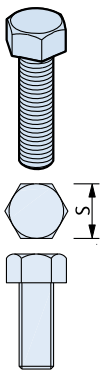

GV 8.8	A4	S	S
galvanized FK 8.8 dimensions	stainless steel thread	DIN [mm]	EN ISO [mm]
M6 × 12		10	10
M6 × 25		13	13
M8 × 25	M8 × 25		
M8 × 40		17	16
M10 × 20			
M10 × 30	M10 × 30		
M10 × 45	M10 × 45		
M10 × 60		19	18
M10 × 70			
M12 × 22			
M12 × 25	M12 × 25		
M12 × 30	M12 × 30		
M12 × 40	M12 × 40		
M12 × 50		24	24
M12 × 60	M12 × 60		
M12 × 80	M12 × 80		
M12 × 90			
M16 × 40	M16 × 40		
M16 × 60	M16 × 60		
M16 × 90	M16 × 90		

Hex bolts are used in combination with HALFEN Threaded plates

SKM

Hexagonal
coupler sleeves
with view holes

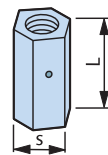

FV	A4	S	L	F _{Rd}	perm. F
hot-dip galvanized thread	stainless steel thread	[mm]	[mm]	① [kN]	[kN]
M10	M10	13	40	9.0	6.4
M12	M12	17	40	13.0	9.3
M16	M16	22	50	24.2	17.3

Ordering example: SKM - FV - M12

SPH

Turnbuckle
with right-
and left-hand
thread

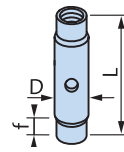

f = minimum
screw depth:
M12 ≙ 10 mm
M16 ≙ 13 mm

A4	A4	D	D
stainless steel thread M12 × length L [mm]	stainless steel thread M16 × length L [mm]	for M12 [mm]	for M16 [mm]
M12 × 60	M16 × 60	16	22
M12 × 75	M16 × 75	16	22
M12 × 95	M16 × 95	16	22
M12 × 115	M16 × 115	16	22
M12 × 135	M16 × 135	16	22
perm. F = 5 kN F _{Rd} = 7 kN	perm. F = 10 kN F _{Rd} = 14 kN		

Ordering example: SPH - A4 - M 12 × 75

HJV

Adjustment
coupler

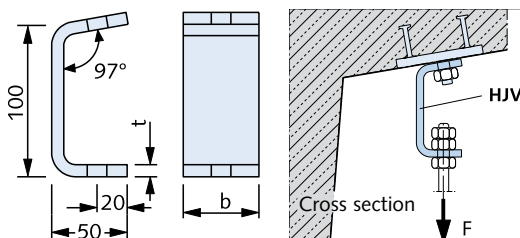
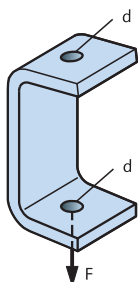

FV	A4	t	b	d	max. F _{Ed}	perm. F
hot-dip galvanized type	stainless steel type	[mm]	[mm]	[mm]	② [kN]	[kN]
1	1	6	40	13	2.1	1.5
2	2	8	50	17	4.6	3.3
3	3	10	50	17	7.0	5

RM

Ring nut
DIN 582
edition 2003-8

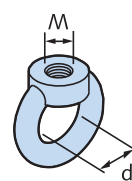

GV	d	F _{Rd}	perm. F
C 15E, galvanized thread	[mm]	① [kN]	[kN]
M8	20	2.0	1.4
M10	25	3.2	2.3
M12	30	4.8	3.4
M16	35	9.8	7.0
M20	40	16.8	12.0

Ordering example: RM - GV - M12

① Recommended design value of the load capacity with a centric tensile stress

② Recommended design value of the load

ACCESSORIES

Rail Clips

KLP-S Rail clips, steel 1.0038 forged

FV hot-dip galvanized	Heel width n [mm]	for HALFEN Bolts $\varnothing \times l$ [mm]	Dimensions [mm]							allowable load at σ allowable = 125 N/mm ² F [kN]	Standard profile I	preferred for use with	
			a	b	c	$\varnothing d$	h	k	m			other beam, flange thickness channels t [mm]	channels
No. 10	16	M16 × 60	44.0	45	12	18	5	12.0	22.0	3.5	80–140	4–6	–
No. 26	without heel	M16 × 60	62.5	64	21	18	9	16.5	34.5	3.5	160–240	7–9	S24, A45, A55
No. 20	20	M20 × 65	50.0	52	18	22	8	15.0	22.0	10.0	160–240	7–9	S24–S49

Ordering example: **KLP - S - Nr. 26 - FV**

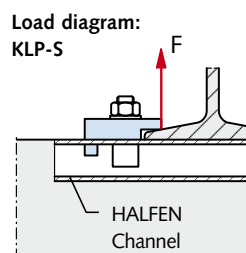
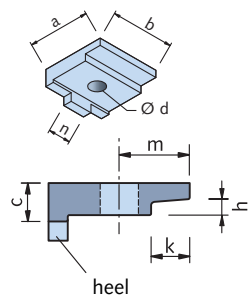

Assembly example KLP-S

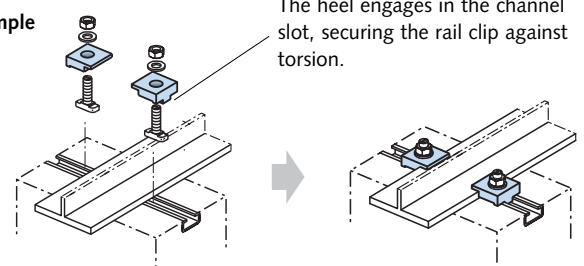

KLP - 60 rail clips

FV Hot-dip galvanized	Clamping height h [mm]	Allowable load ^② [kN]	Preferred for use with		
			Standard profile I	Standard profile IPB	Crane and running tracks ^④
60/10	10	$F_1 = 7.0$ HALFEN Bolt M16 × 60, Grade 4.6	120–160	100	A65, S33, S41
60/12	12		220–240	140	A100, S49, A75
60/14	14		240–280	160–180	A120, S54
60/16	16	$F_2 = 11.25$ HALFEN Bolt M16 × 60, Grade 8.8	300–340	200–220	S64
60/18	18 ^③		360–380	240–260	–
60/20	20 ^③		400–450	280–300	–

② Take the load capacity of HALFEN Channels into account (Cantilever must be considered when selecting the HALFEN Channels and Bolts)

③ Bolt M16 × 80 necessary

④ Check flange thickness of profile!

Order example: **KLP - 60/10 - FV**

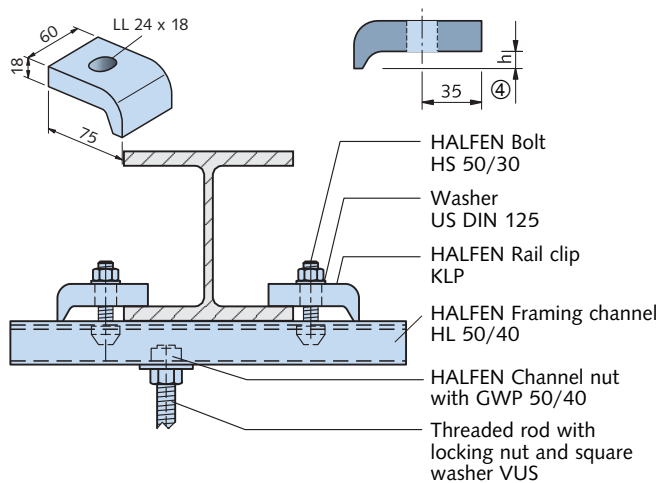

Load diagram KLP - 60

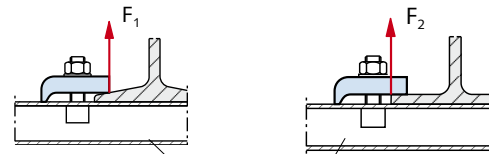

Assembly example KLP - 60

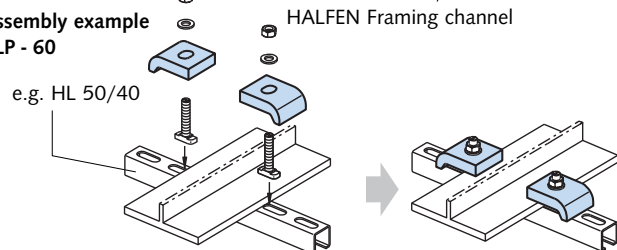

ACCESSORIES

Framing Channels HM/HZM/HL/HZL -Type Overview

Heavy Duty Framing System														
Hot-rolled				Cold-rolled			Hot-rolled	Cold-rolled		Hot-rolled, serrated				
HM 72/48	HM 55/42	HM 52/34	HM 50/30	HM 49/30	HM/HL 50/40	HM 486	HM 40/22	HM 40/25	HM 422	HZM 64/44	HZM 53/34	HZM 41/27	HZM 38/23	HZM 29/20
72 33	54.5 26	52.5 22.5	49 22.5	50 22	49 22	48 22	39.5 18	40 18	39.5 18	64 26	52.5 22.5	40 18.5	38 18	29 14
HS / HSR 72/48, GWP 72/48	HS 50/30	HS / HSR 50/30, GWP 50/30		HS 50/30, GWP 50/30 or GWP 50/40			HS / HSR 40/22, GWP 40/22			HZS 64/44	HZS 53/34	HZS 38/23	HZS 38/23, HS 38/17	HZS 29/20, HS 28/15

Medium Duty Framing System								
Cold-rolled	Cold-rolled, serrated	Cold-rolled		Cold-rolled, serrated		Cold-rolled	Cold-rolled	
HM / HL 41/41	HZM / HZL 41/41	HM / HL 41/62	HM / HL 41/83	HZL 63/63	HZM / HZL 41/22	HM / HL 41/22	HLL 41/41	HLL 41/22
41 22	41 22	41 22	41 22	41 22	41 22	41 22	41 22	41 22
							HZS/HS 41/41, HZS 41/22 GWP 41/41, GWP 41/22	

Light Duty Framing System						
Cold-rolled					Cold-rolled	
HM 36/36, HL 36/36	HM 38/17	HM 28/28, HL 28/28	HM 26/26, HL 26/26	HM 28/15, HL 28/15	HM 315	HM 20/12, HL 20/12
36 18	38 18	28 12	26 12	28 12	30 16	20 10
HS 38/17, GWP 38/17		HS 28/15, GWP 28/15			GWP 28/15	HS 20/12, GWP 20/12

Materials/Finish:

- Steel hot-dip galvanized FV or Steel mill finished WB
- Steel, sendzimir galvanized SV
- Stainless steel A4 1.4571/1.4404
- Stainless steel A2 1.4307
- Stainless steel HCR 1.4547/1.4529

For information on materials → see page 11

serrated profiles HZM/HZL

ACCESSORIES

Framing Channels HM/HZM/HL/HZL – Application Examples

Type Overview

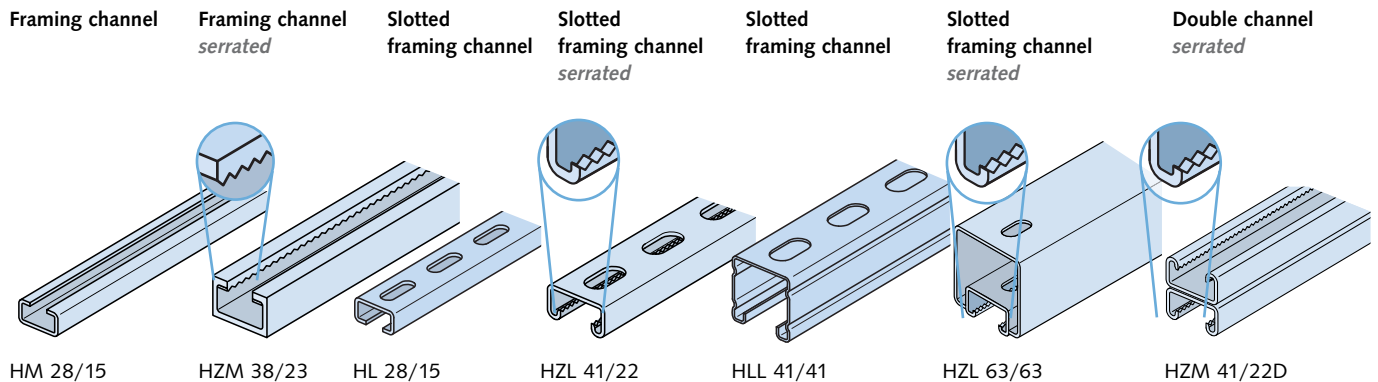

Application Examples

HALFEN Framing channels HM/HZM and slotted HALFEN Framing channels HL/HZL can be attached to a substructure in a number of ways:

- ① fastened to concrete or masonry with wedge anchors HB-VMU plus
- ② bolted to HALFEN Cast-in channels type HTA-CE and HZA
- ③ connected to threaded rods
- ④ clamped to steel profile supports
- ⑤ welded to steel components
- ⑥ screwed or nailed to wooden structures

HALFEN Framing channels are a part of the HALFEN Framing system:

- installations for plant engineering
- technical equipment in buildings
- heavy and light installations

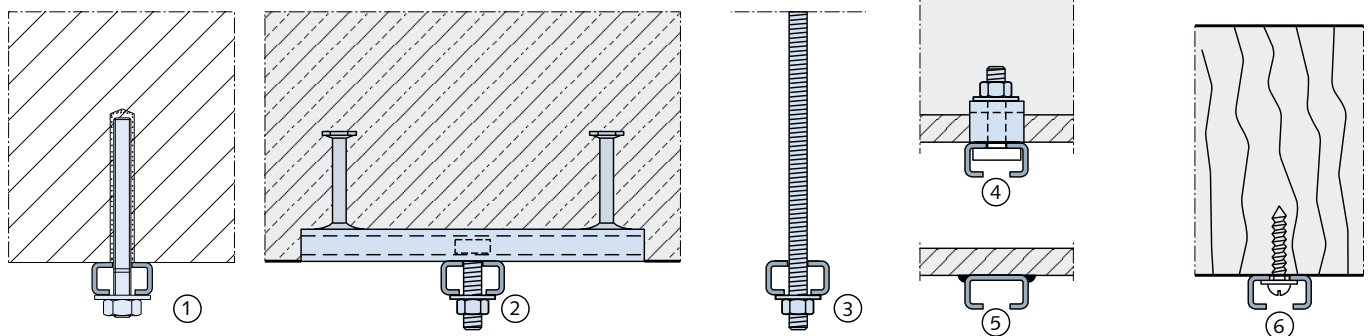

Typical application of the HALFEN Powerclick system

The product range for framing system applications can be found in the following Technical Product Informations:
HALFEN Flexible bolt connections,
HALFEN Flexible framing connections
 or **HALFEN Powerclick System.**



APPENDIX

Index

	Page:		Page:
Accessories	84–89	HZM Framing channels, serrated	88–89
Adjustment coupler HJV	86	HZS HALFEN Bolts, serrated	32–35
BL, BLQ brick tie anchor	62–65	Locking washer SIC	85
Brick tie anchor ML, BL	62–65	ML, MLQ Brick tie anchor	62–65
Brick tie channel HMS	62, 64	Nuts MU	85
Cold-rolled channels HTA-CE	16–17	Perforated framing channels HL, HZL	88–89
Cold-rolled channels HZA	31	Precast connection HVL	69
Corner guard HKW	70	Profiled metal sheet fixing channel HTU	52–57
Corrosion protection HALFEN Channels & bolts	11–12, 31	Profiles HM, HL	88–89
Coupler sleeves VBM, SKM	86	Profiles, serrated, HZM, HZL	88–89
Curved HALFEN Cast-in channels HTA-CE, HZA	25	Rafter shoe HSF	60
Dowels	63	Rail clips KLP	87
DYNAGRIP HALFEN Cast-in channels	29–37	Restraint tie HKZ	67–68
Dynamic Loads for HALFEN Cast-in channels	37	Restraint with turnbuckle SPV	66
End anchor ANK-E for HALFEN Channels HTA	24	Ring nuts RM	86
Firewall connection (masonry)	65	Serrated profiles HZA Cast-in channels	29–37
Framing channels HM, HL,	88–89	Serrated profiles HZM, HZL Framing channels	88–89
Framing channels, serrated HZM, HZL		Short & cut lengths of HALFEN Channels	18, 35
HALFEN Bolts	19–23	SIC Locking washer	85
HALFEN Cast-in channels	5	SKM Coupler sleeve	86
HALFEN Cast-in channels; corner elements	25	SPH turnbuckle with right- and left-hand threads	86
HALFEN Framing channels	88–89	SPV Restraint with turnbuckle	66
HCW Curtain Wall System	71–83	Square washers VUS	85
Hexagonal coupler SKM	86	Standard lengths for HALFEN Channels HTA-CE	18
Hexagonal nuts - bolts	85–86	Standard lengths for HALFEN Channels HZA	35
HGB Handrail connection systems	38–51	Threaded rods	86
HKW Corner guard	70	Timber fixing	58–61
HKZ Restraint tie, serrated	67–68	Turnbuckle with right- and left-hand thread SPH	86
HL Framing channels, slotted	88–89	VBM Coupler sleeve	86
HM Framing channels	88–89	VUS Washer	85
HMS Brick tie channels	62, 64	US Washer	85
HNA Timber fixing straps	61	Washer US, VUS	85
Hot-rolled channels HTA-CE	16–17		
Hot-rolled channels HZA	31		
HS HALFEN Bolts	19–22		
HSF Rafter shoe	60		
HSR HALFEN Bolts with nib	23		
HTA-CE HALFEN Cast-in Channels	7–28		
HTU Profiled metal sheets fixing channels	52–57		
HVL Precast connection	69		
HZA HALFEN Cast-in channel DYNAGRIP	29–37		
HZA HALFEN Cast-in channel, serrated	29–37		
HZL Framing channels, slotted	88–89		

CONTACT HALFEN WORLDWIDE

HALFEN is represented by subsidiaries in the following countries, please contact us!

Austria	HALFEN Gesellschaft m.b.H. Leonard-Bernstein-Str. 10 1220 Wien	Phone: +43-1-259 6770 E-Mail: office@halfen.at Internet: www.halfen.at	Fax: +43-1-259-677099
Belgium / Luxembourg	HALFEN N.V. Borkelstraat 131 2900 Schoten	Phone: +32-3-658 0720 E-Mail: info@halfen.be Internet: www.halfen.be	Fax: +32-3-658 1533
China	HALFEN Construction Accessories Distribution Co.Ltd. Room 601 Tower D, Vantone Centre No. A6 Chao Yang Men Wai Street Chaoyang District Beijing · P.R. China 100020	Phone: +86-10 5907 3200 E-Mail: info@halfen.cn Internet: www.halfen.cn	Fax: +86-10 5907 3218
Czech Republic	HALFEN s.r.o. Business Center Šafránkova Šafránkova 1238/1 155 00 Praha 5	Phone: +420-311-690 060 E-Mail: info@halfen-deha.cz Internet: www.halfen-deha.cz	Fax: +420-235-314 308
France	HALFEN S.A.S. 18, rue Goubet 75019 Paris	Phone: +33-1-445231 00 E-Mail: halfen@halfen.fr Internet: www.halfen.fr	Fax: +33-1-445231 52
Germany	HALFEN Vertriebsgesellschaft mbH Liebigstr. 14 40764 Langenfeld	Phone: +49-2173-970-0 E-Mail: info@halfen.de Internet: www.halfen.de	Fax: +49-2173-970 225
Italy	HALFEN S.r.l. Soc. Unipersonale Via F.lli Bronzetti N° 28 24124 Bergamo	Phone: +39-035-0760711 E-Mail: tecnico@halfen.it Internet: www.halfen.it	Fax: +39-035-0760799
Netherlands	HALFEN b.v. Oostermaat 3 7623 CS Borne	Phone: +31-74-267 14 49 E-Mail: info@halfen.nl Internet: www.halfen.nl	Fax: +31-74-267 26 59
Norway	HALFEN AS Postboks 2080 4095 Stavanger	Phone: +47-51 82 34 00 E-Mail: post@halfen.no Internet: www.halfen.no	Fax: +47-51 82 34 01
Poland	HALFEN Sp. z o.o. Ul. Obornicka 287 60-691 Poznan	Phone: +48-61-622 14 14 E-Mail: info@halfen.pl Internet: www.halfen.pl	Fax: +48-61-622 14 15
Spain	HALFEN Spain PLAKABETON S.L. Polígono Industrial Santa Ana c/ Ignacio Zuloaga 20 28522 Rivas-Vaciamadrid	Phone: +34 916 669 181 E-Mail: info@halfen.es Internet: www.halfen.es	Fax: +34 916 669 661
Sweden	Halfen AB Vädursgatan 5 412 50 Göteborg	Phone: +46-31-98 58 00 E-Mail: info@halfen.se Internet: www.halfen.se	Fax: +46-31-98 58 01
Switzerland	HALFEN Swiss AG Hertistrasse 25 8304 Wallisellen	Phone: +41-44-849 78 78 E-Mail: info@halfen.ch Internet: www.halfen.ch	Fax: +41-44-849 78 79
United Kingdom / Ireland	HALFEN Ltd. A1/A2 Portland Close Houghton Regis LU5 5AW	Phone: +44-1582-47 03 00 E-Mail: info@halfen.co.uk Internet: www.halfen.co.uk	Fax: +44-1582-47 03 04
United States of America	HALFEN USA Inc. PO Box 18687 San Antonio TX 78218	Phone: +1 800.423.91 40 E-Mail: info@halfenusa.com Internet: www.halfenusa.com	Fax: +1 877.683.4910
For countries not listed HALFEN International	HALFEN International GmbH Liebigstr. 14 40764 Langenfeld / Germany	Phone: +49-2173-970-0 E-Mail: info@halfen.com Internet: www.halfen.com	Fax: +49-2173-970-849

NOTES REGARDING THIS CATALOGUE

Technical and design changes reserved. The information in this publication is based on state-of-the-art technology at the time of publication. We reserve the right to make technical and design changes at any time. HALFEN GmbH shall not accept liability for the accuracy of the information in this publication or for any printing errors.

The HALFEN GmbH subsidiaries in Germany, France, the Netherlands, Austria, Poland, Switzerland and the Czech Republic are Quality Management certified according to **ISO 9001:2015**, Certificate no. 202384-2016-AQ-GER-DAKKS.





For further information please contact: www.halfen.com