

HALFEN HSD SHEAR DOWEL SYSTEM

TECHNICAL PRODUCT INFORMATION



HALFEN HSD SHEAR DOWEL SYSTEM

HSD 08-E

CONCRETE

Acc. to DIN 1045-1

Officially approved
Z-15.7-253

HALFEN HSD SHEAR DOWEL SYSTEM

Introduction

Expansion joints to prevent constraint stresses

The effects of

- Shrinkage
- Temperature
- Creep
- Subsidence

require constructive measures in large supporting frameworks.

Movement joints prevent the uncontrolled formation of cracks and the subsequent damage that arises from this as a result of leakage and corrosion.

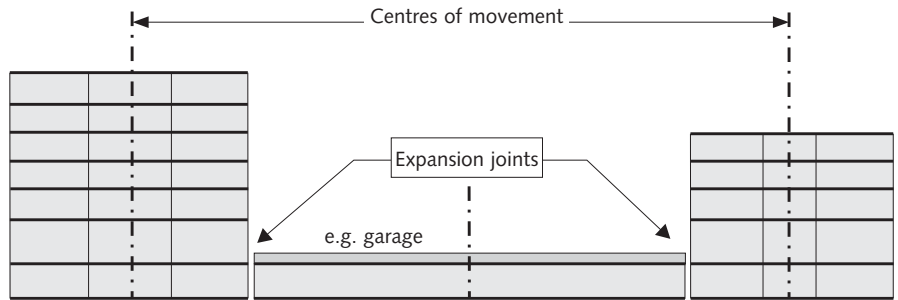

Problems with conventional solutions The solution: The HALFEN HSD Shear dowel system

Example 1, floor or ceiling slabs:

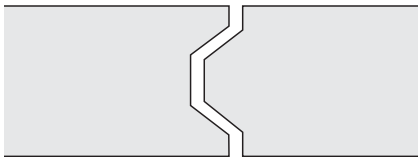

Conventional shear keying of a floor slab:
Expensive and prone to damage.

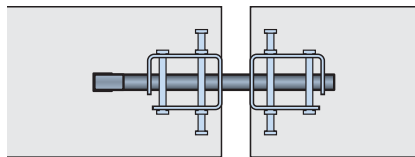

Economically and technically flawless: Implementation using HALFEN shear dowel

Example 2, beam connection:

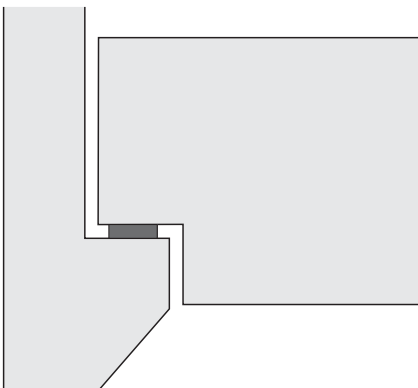

Disadvantageous: Movable support on the console; higher formwork and reinforcement outlay, poor use of the space in the area of the thrust bearing.

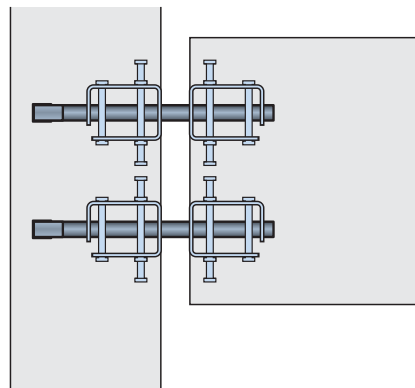

Movable support with the HALFEN heavy-duty shear dowel; support consoles are unnecessary. Valuable gain of space! Planning outlay is reduced!

- Advantages of the HALFEN shear dowel system:
- Simple geometry of the formation of the joint.
 - Simple formwork and installation time saving.
 - Simple guidance of the reinforcement.
 - Gain in space through avoidance of double supports (see page 3).
 - Cost saving and gain in space through staged erection of the construction elements (see page 3).
 - Approved by the German Construction Supervisory Board DIBt, Approval No. Z-15.7-253.
 - User-friendly HSD Dimensioning Software available in the Internet (→ www.halfen.com → Software/CAD).
 - Fire-resistance classification F120 designable with fire protection pads (see page 5).

HALFEN HSD SHEAR DOWEL SYSTEM

Application

Conventional joint design

Joints with HALFEN HSD shear dowel

a) Application area for HALFEN CRET heavy-duty shear dowels → see pages 6 - 13.

Flat slab (vertical section)

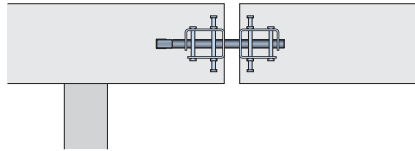
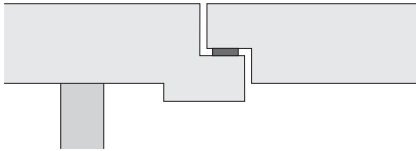

Slab connection with console (vertical section)

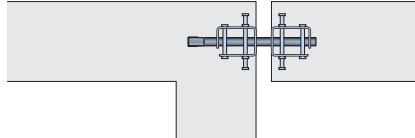
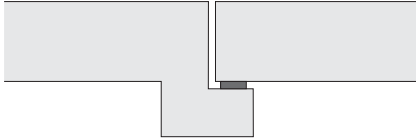

Double column replaced by a single column (vertical section)

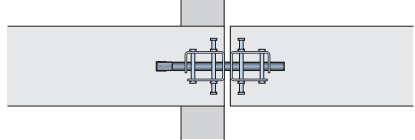
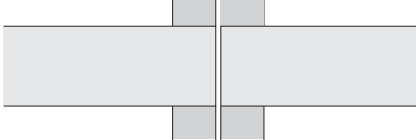

Connection of a supporting wall (horizontal section)

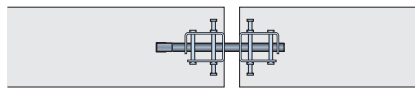
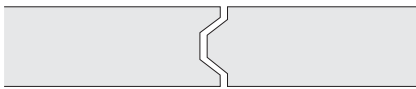

Expansion joint in floor slab (vertical section)

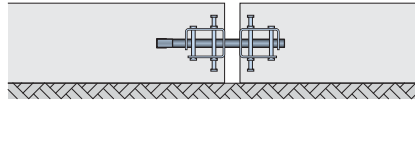
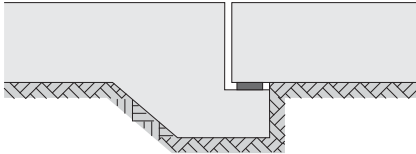

Connection between beam / support (vertical section)

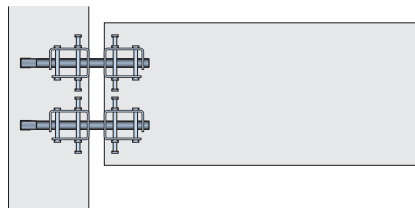
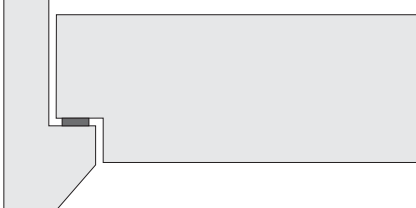

Construction phases:

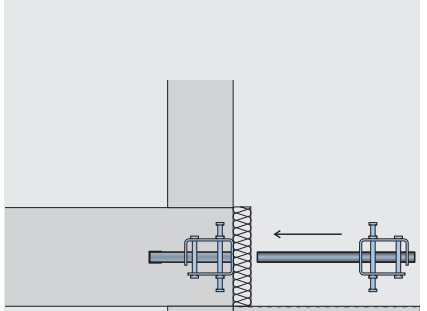

Following the first concrete work section, the formwork is set and the HSD-CRET dowel element is positioned.

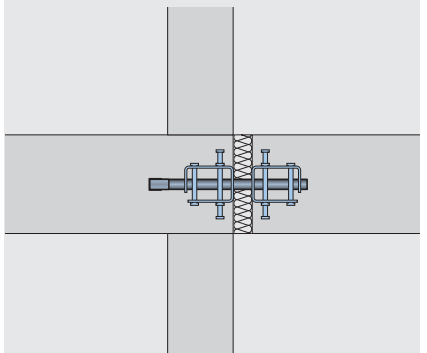

Final state of construction element using the HALFEN HSD shear dowel.

b) Application area for HALFEN single shear dowels → see pages 14 - 18

Expansion joint with HALFEN single shear dowel between 2 freely projecting balcony slabs (top view)

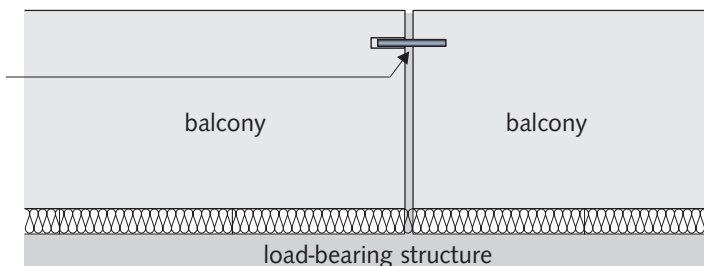

Dowelling at the support of a pre-cast reinforced concrete beam on a console.

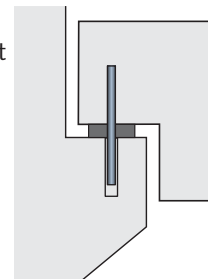

HALFEN HSD SHEAR DOWEL SYSTEM

Dimensioning

Expansion joints to prevent constraint stresses

For flat slabs, it is advisable to arrange the dowels at different spacings according to the different shear load concentrations. The value and the distribution of the shear load to be transmitted can be determined by an finite elements slab calculation. The static model of a continuous beam is suitable for the dimensioning of the edge of the slab. Shear and bending moments will be used for the dimensioning of the reinforcement across and along the edge. It must thereby be noted that, as a result of the proof of the punching shear load capacity, transverse and longitudinal reinforcement is also required in the load introduction area of the dowel, which could be decisive against those from the continuous beam calculation. With large dowel spacings, the continuous beam calculation is normally the decisive value for the longitudinal reinforcement.

Dimensioning of the joint width f
 $f = \text{calculated joint width} + \text{safety supplement (approx. 1cm)}$

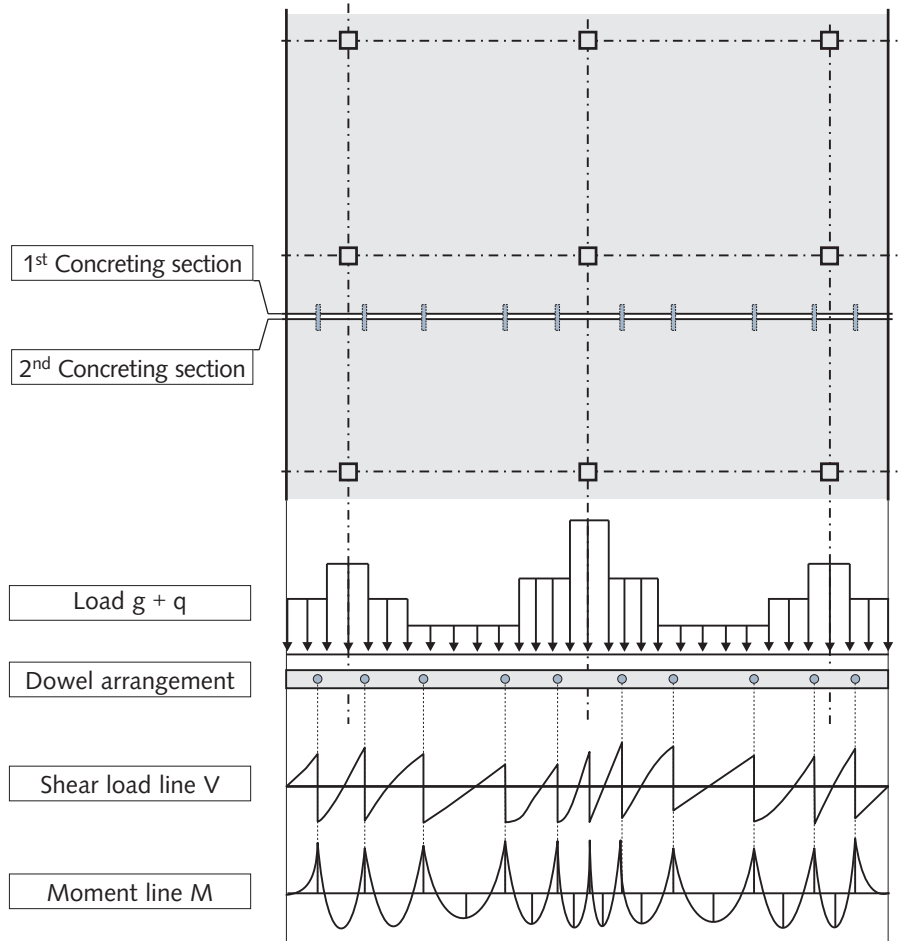

Arrangement of the shear dowel - Examples

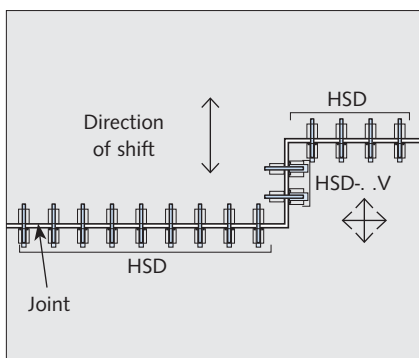

Angled joint run

Shifting direction of the shear dowels:

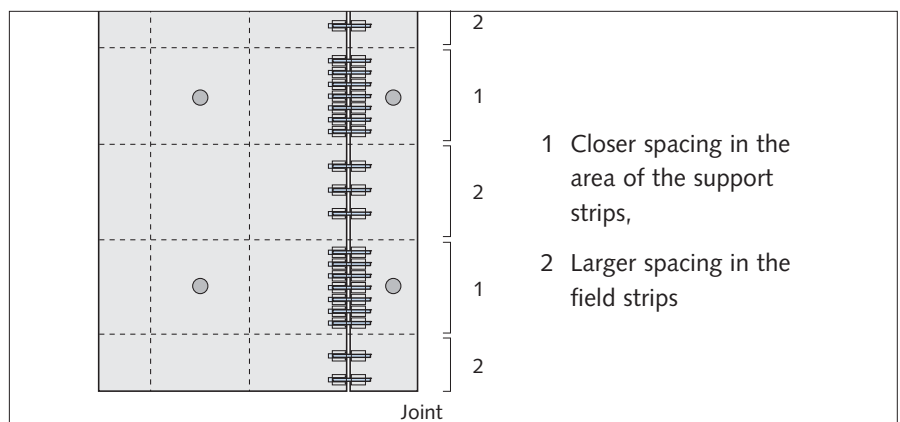
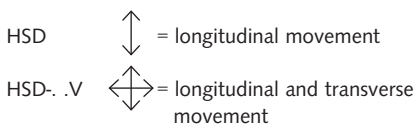

Flat slab joint; dowel arrangement corresponding to the support model for the slab

HALFEN HSD SHEAR DOWEL SYSTEM

Fire protection

HSD-F fire protection pad

If fire-protection is required for components according to DIN 4102 T.2, we recommend to install the HALFEN HSD shear dowels with fire protection pads.

The fire protection pad can be supplied 20 mm ($d = 20$) and 30 mm ($d = 30$) thick. For larger joint widths, a combination of fire protection pads is possible.

The Fire-resistance classification F120 (longitudinal movement) or F90 (longitudinal and transverse movement) is confirmed by the MFPA Leipzig.

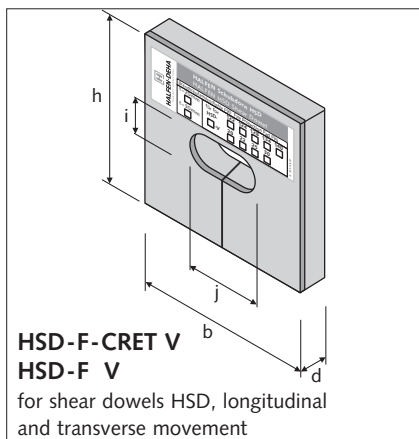
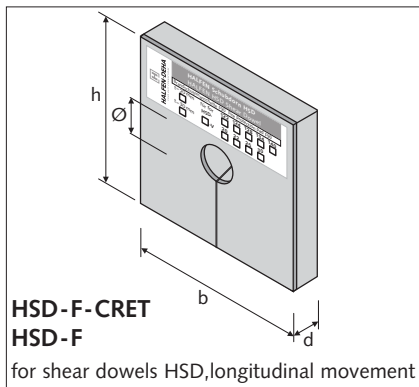

Ordering example:
HSD-F - CRET 124 V - 30

Fire protection pad
 Matching dowel type
 Thickness d [mm]

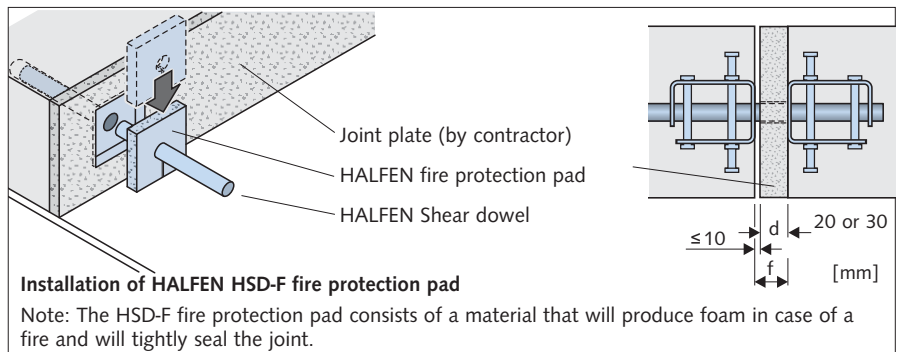

Fire protection pad selection

matching the HALFEN HSD shear dowel -	Item name $d = 20 \Rightarrow f \leq 30$ $d = 30 \Rightarrow f \leq 40$	h / b	Ø or i	j
Heavy-duty dowel, longitudinal movement				
CRET 122	HSD-F-CRET 122 - d	120 / 120	23	
CRET 124	HSD-F-CRET 124 - d	130 / 130	25	
CRET 128	HSD-F-CRET 128 - d	140 / 140	29	
CRET 134	HSD-F-CRET 134 - d	160 / 180	35	
CRET 140	HSD-F-CRET 140 - d	180 / 220	41	
Single dowel, longitudinal movement				
Set 20	HSD-F 20 - d	110 / 110	21	
Set 22	HSD-F 22 - d	110 / 110	23	
Set 25	HSD-F 25 - d	110 / 110	26	
Set 30	HSD-F 30 - d	110 / 110	31	
Heavy-duty dowel, longitudinal and transverse movement				
CRET-122 V	HSD-F-CRET 122 V - d	120 / 120	23	46
CRET-124 V	HSD-F-CRET 124 V - d	130 / 130	25	50
CRET-128 V	HSD-F-CRET 128 V - d	140 / 140	29	58
CRET-134 V	HSD-F-CRET 134 V - d	160 / 180	35	70
CRET-140 V	HSD-F-CRET 140 V - d	180 / 220	41	82
Single dowel, longitudinal and transverse movement				
Set 20 V	HSD-F 20 V - d	110 / 160	21	42
Set 22 V	HSD-F 22 V - d	110 / 160	23	46
Set 25 V	HSD-F 25 V - d	110 / 160	26	52
Set 30 V	HSD-F 30 V - d	110 / 160	31	62

For requirements -enclosure of space- according DIN EN 1366-4 in combination with DIN EN 1363-1, we recommend to use the joint element **PROMASEAL-PL** (see fig.).

For the combination of HALFEN shear dowel with PROMASEAL-PL the enclosing design function and the fire-resistance classification F90 is confirmed by the MFPA Leipzig.

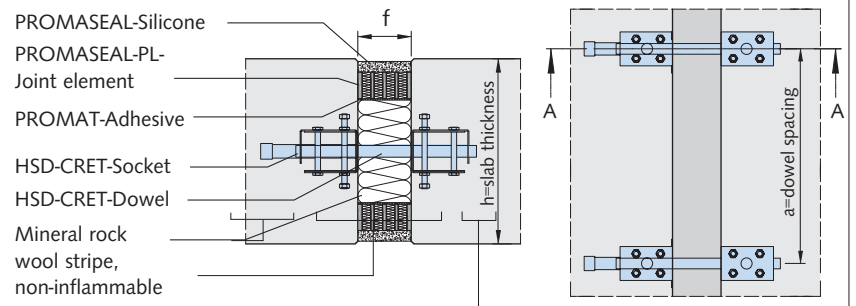

HALFEN HSD SHEAR DOWEL SYSTEM

Heavy-duty shear dowels

Product description

HSD-CRET heavy-duty shear dowel

consisting of dowel part and sliding socket, single-axis movement - along the dowel axis

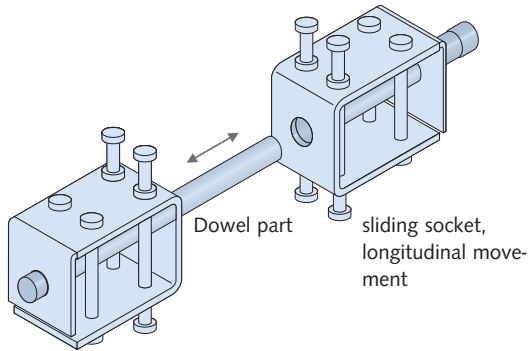

HSD-CRET V heavy-duty shear dowel

consisting of dowel part and sliding socket, two-axis movement - along the dowel axis and parallel to the joint

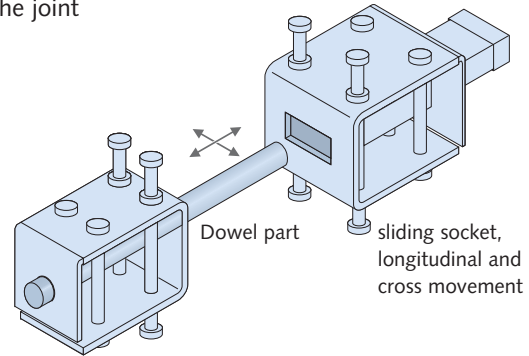

HALFEN HSD-CRET heavy-duty shear dowels allow a sliding movement in the direction of the dowel axis. The dowels are normally used to transfer shear loads in any direction. A high load capacity is effectuated by the load distribution body. If lateral movements must be considered, the HALFEN HSD-CRET V heavy-duty shear dowel is used, which allows also lateral movement. In this case, the shear load will only be transferred in one direction.

Technical data

Dowel diameter and minimum component thickness

HSD-	HSD-	Dowel diameter [mm]	Minimum component thickness h_{min} [cm]
CRET 122	CRET 122 V	22	18
CRET 124	CRET 124 V	24	20
CRET 128	CRET 128 V	28	24
CRET 134	CRET 134 V	34	30
CRET 140	CRET 140 V	40	35

Materials

- Dowel: stainless steel S 690 (grade 1.4462)
- Load distribution body and sliding socket: Stainless steel S 275 (grade 1.4404)
- Fixing rod: Stainless steel, strength class 70 (grade 1.4401)

All materials correspond to at least the corrosion-resistance class III.

Installation in semi-prefabricated slabs

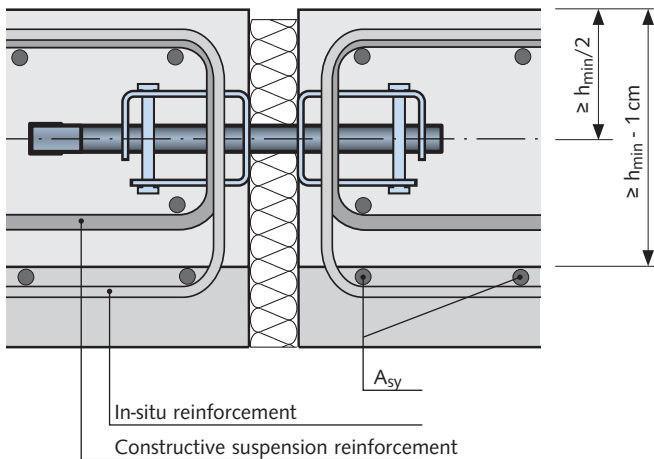

Recommendation:

- Insertion of constructive suspension reinforcement in the semi-prefabricated slab (dimensioning for VRd/3).
- Thickness of the in-situ cast concrete = $h_{min} - 1 \text{ cm}$.
- Dimension between the shear dowel axis and upper edge of the in-situ cast concrete = $h_{min}/2$.
- With a sufficient thickness of the in-situ cast concrete, the reinforcement A_{sy} can also be placed outside the semi-prefabricated slab.
- In-situ reinforcement (A_{sx} and A_{sy} top) is to be arranged according to the tables on pages 11 and 12 and/or the approval.

HALFEN HSD SHEAR DOWEL SYSTEM

Heavy-duty shear dowels

Type selection

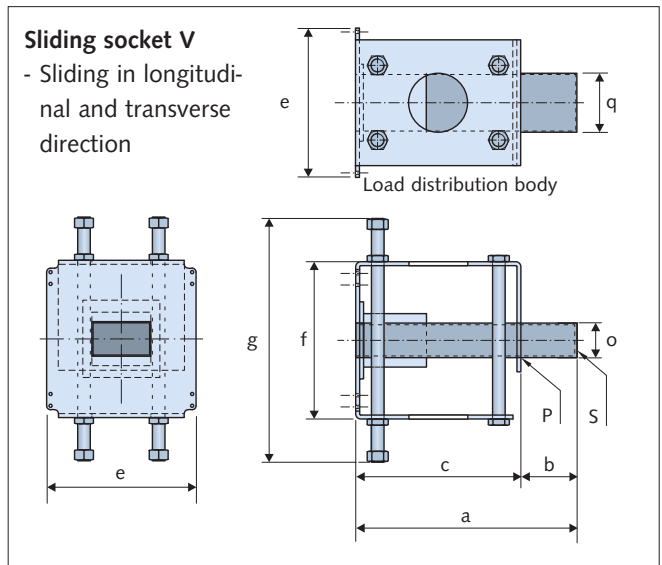
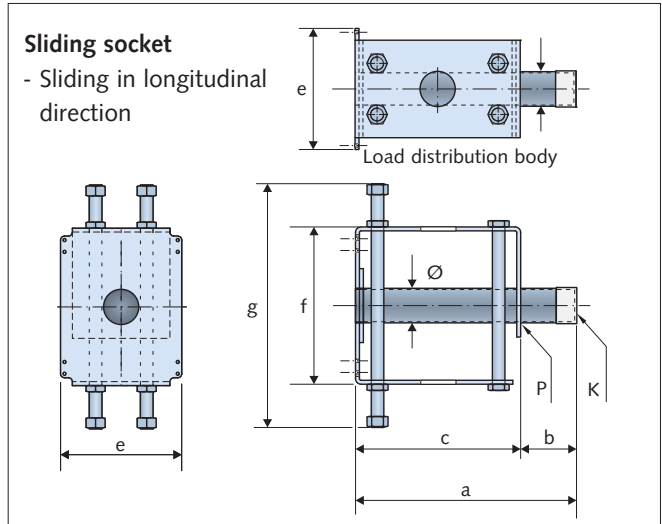
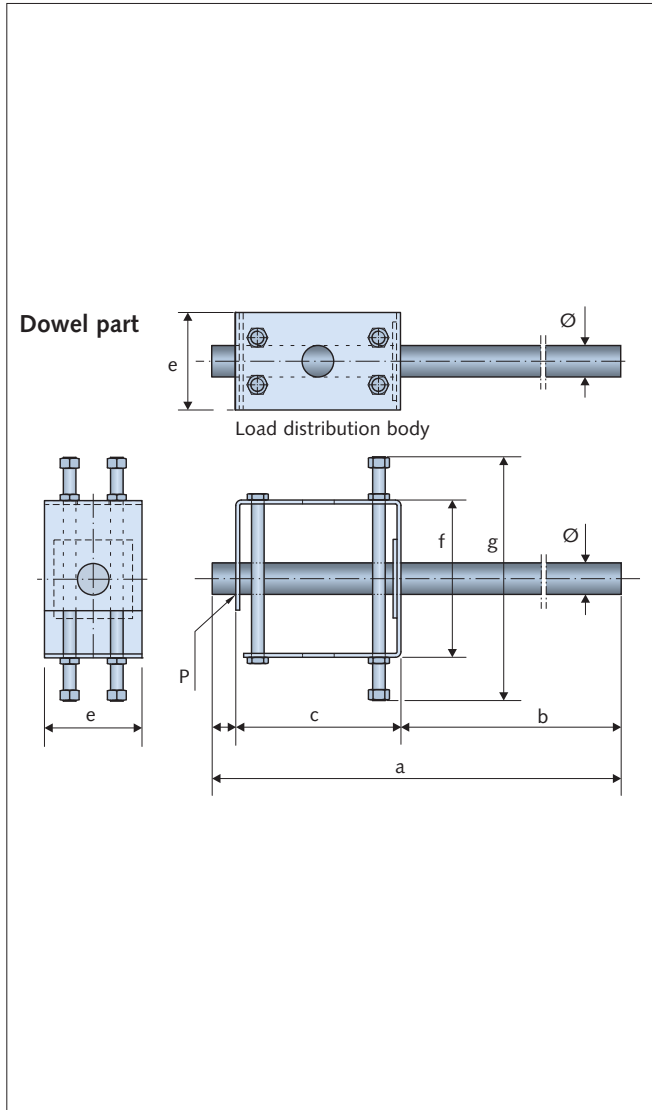

Ordering example:

HALFEN heavy-duty shear dowel **HSD-CRET 124 V**
Load range
V = Transverse and longitudinal movement

P = Spot welding
K = PE pipe protection cap
S = Sheet metal cover

Dimensions [mm]															
	HSD-CRET 122 HSD-CRET 122 V			HSD-CRET 124 HSD-CRET 124 V			HSD-CRET 128 HSD-CRET 128 V			HSD-CRET 134 HSD-CRET 134 V			HSD-CRET 140 HSD-CRET 140 V		
	Dowel part	Socket	Socket V	Dowel part	Socket	Socket V	Dowel part	Socket	Socket V	Dowel part	Socket	Socket V	Dowel part	Socket	Socket V
a	302	180	181,5	341	192	193,5	388	215	217	450	246	248	520	280	281,5
b	180	72	73,5	192	59	60,5	215	60	62	246	66	68	280	70	71,5
c	108	108	108	133	133	133	155	155	155	180	180	180	210	210	210
d	14	—	—	16	—	—	18	—	—	24	—	—	30	—	—
e	70	100	125	76	106	133	88	118	146	106	136	168	124	154	190
f	80	80	80	90	90	90	110	110	110	160	160	160	200	200	200
g	140	140	140	160	160	160	200	200	200	260	260	260	310	310	310
Ø	22	25,4	—	24	28	—	28	32	—	34	38	—	40	44	—
o	—	—	26	—	—	28	—	—	32	—	—	38	—	—	44
q	—	—	50	—	—	55	—	—	60	—	—	70	—	—	75

HALFEN HSD SHEAR DOWEL SYSTEM

Heavy-duty shear dowels

Dimensioning

$$V_{Rd} = \min (V_{Rd,s(Dorm)}; V_{Rd,c}; V_{Rd,ct})$$

$V_{Rd,s}$ Design value of the resistance of the steel load-bearing capacity

$V_{Rd,c}$ Design value of the resistance against concrete edge failure

$V_{Rd,ct}$ Design value of the resistance against punching failure

A dowel can be selected from these tables, no further proofs are required.

The values quoted for the maximum dimensioning resistance V_{Rd} only apply for an arrangement of the junction reinforcement according to the tables on page 11.

Relevant dimensioning resistances V_{Rd} [kN] HSD-CRET shear dowels with longitudinal movement ①																
Shear dowel	Component thickness [mm]	C20/25					C30/37					C40/50				
		Joint width [mm]					Joint width [mm]					Joint width [mm]				
		20	30	40	50	60	20	30	40	50	60	20	30	40	50	60
HSD-CRET 122	180	45.0	45.0	45.0	40.1	33.4	55.8	55.8	50.1	40.1	33.4	65.1	65.1	50.1	40.1	33.4
	200	61.9	61.9	50.1	40.1	33.4	76.8	66.4	50.1	40.1	33.4	85.6	66.4	50.1	40.1	33.4
	220	79.2	66.4	50.1	40.1	33.4	85.6	66.4	50.1	40.1	33.4	85.6	66.4	50.1	40.1	33.4
	240	85.6	66.4	50.1	40.1	33.4	85.6	66.4	50.1	40.1	33.4	85.6	66.4	50.1	40.1	33.4
	250	85.6	66.4	50.1	40.1	33.4	85.6	66.4	50.1	40.1	33.4	85.6	66.4	50.1	40.1	33.4
HSD-CRET 124	200	62.0	62.0	62.0	52.0	43.4	77.0	77.0	65.0	52.0	43.4	89.7	84.8	65.0	52.0	43.4
	220	79.4	79.4	65.0	52.0	43.4	98.2	84.8	65.0	52.0	43.4	105.7	84.8	65.0	52.0	43.4
	240	95.4	84.8	65.0	52.0	43.4	105.7	84.8	65.0	52.0	43.4	105.7	84.8	65.0	52.0	43.4
	250	99.1	84.8	65.0	52.0	43.4	105.7	84.8	65.0	52.0	43.4	105.7	84.8	65.0	52.0	43.4
	260	105.7	84.8	65.0	52.0	43.4	105.7	84.8	65.0	52.0	43.4	105.7	84.8	65.0	52.0	43.4
HSD-CRET 128	240	98.8	98.8	98.8	82.6	68.8	123.1	123.1	103.2	82.6	68.8	144.0	127.6	103.2	82.6	68.8
	250	120.8	120.8	103.2	82.6	68.8	149.9	127.6	103.2	82.6	68.8	151.9	127.6	103.2	82.6	68.8
	260	125.0	125.0	103.2	82.6	68.8	151.9	127.6	103.2	82.6	68.8	151.9	127.6	103.2	82.6	68.8
	280	133.4	127.6	103.2	82.6	68.8	151.9	127.6	103.2	82.6	68.8	151.9	127.6	103.2	82.6	68.8
	300	144.0	127.6	103.2	82.6	68.8	151.9	127.6	103.2	82.6	68.8	151.9	127.6	103.2	82.6	68.8
	320	145.3	127.6	103.2	82.6	68.8	151.9	127.6	103.2	82.6	68.8	151.9	127.6	103.2	82.6	68.8
	340	151.9	127.6	103.2	82.6	68.8	151.9	127.6	103.2	82.6	68.8	151.9	127.6	103.2	82.6	68.8
HSD-CRET 134	300	184.5	184.5	177.5	147.9	123.3	226.8	207.1	177.5	147.9	123.3	236.7	207.1	177.5	147.9	123.3
	320	187.3	187.3	177.5	147.9	123.3	234.5	207.1	177.5	147.9	123.3	236.7	207.1	177.5	147.9	123.3
	340	198.3	198.3	177.5	147.9	123.3	236.7	207.1	177.5	147.9	123.3	236.7	207.1	177.5	147.9	123.3
	350	203.8	203.8	177.5	147.9	123.3	236.7	207.1	177.5	147.9	123.3	236.7	207.1	177.5	147.9	123.3
	360	209.2	207.1	177.5	147.9	123.3	236.7	207.1	177.5	147.9	123.3	236.7	207.1	177.5	147.9	123.3
HSD-CRET 140	350	214.6	214.6	214.6	214.6	200.7	270.3	270.3	270.3	235.5	200.7	309.4	305.1	270.3	235.5	200.7
	360	220.1	220.1	220.1	220.1	200.7	277.3	277.3	270.3	235.5	200.7	326.9	305.1	270.3	235.5	200.7
	380	230.8	230.8	230.8	230.8	200.7	291.4	291.4	270.3	235.5	200.7	339.9	305.1	270.3	235.5	200.7
	400	241.5	241.5	241.5	235.5	200.7	305.2	305.1	270.3	235.5	200.7	339.9	305.1	270.3	235.5	200.7
	450	267.6	267.6	267.6	235.5	200.7	339.2	305.1	270.3	235.5	200.7	339.9	305.1	270.3	235.5	200.7
HSD-CRET 140 ②	350	259.2	259.2	259.2	235.5	200.7	321.9	305.1	270.3	235.5	200.7	339.9	305.1	270.3	235.5	200.7
	360	266.2	266.2	266.2	235.5	200.7	331.7	305.1	270.3	235.5	200.7	339.9	305.1	270.3	235.5	200.7
	380	280.2	280.2	270.3	235.5	200.7	339.9	305.1	270.3	235.5	200.7	339.9	305.1	270.3	235.5	200.7
	400	293.9	293.9	270.3	235.5	200.7	339.9	305.1	270.3	235.5	200.7	339.9	305.1	270.3	235.5	200.7
	450	327.4	305.1	270.3	235.5	200.7	339.9	305.1	270.3	235.5	200.7	339.9	305.1	270.3	235.5	200.7
		339.9	305.1	270.3	235.5	200.7	339.9	305.1	270.3	235.5	200.7	339.9	305.1	270.3	235.5	200.7

① Load-bearing capacities for concrete strengths C25/30 and C35/40 can be interpolated. ② Values apply for increased reinforcement according to the table on page 11

 = steel load-bearing capacity decisive
 = Concrete edge failure decisive
 = Punching failure decisive

HALFEN HSD SHEAR DOWEL SYSTEM

Heavy-duty shear dowels

Dimensioning

The values quoted for maximum design resistance V_{Rd} only apply for an arrangement of the junction reinforcement according to the tables on page 12.

Relevant design resistances V_{Rd} [kN] HSD-CRET V shear dowels with longitudinal and transverse movement ①																
Shear dowel	Component thickness [mm]	C20/25					C30/37					C40/50				
		Joint width [mm]					Joint width [mm]					Joint width [mm]				
		20	30	40	50	60	20	30	40	50	60	20	30	40	50	60
HSD-CRET 122 V	180	37.6	37.6	37.6	36.1	30.1	46.5	46.5	45.1	36.1	30.1	54.1	54.1	45.1	36.1	30.1
	200	50.5	50.5	45.1	36.1	30.1	62.4	59.8	45.1	36.1	30.1	72.5	59.8	45.1	36.1	30.1
	220	65.3	59.8	45.1	36.1	30.1	77.0	59.8	45.1	36.1	30.1	77.0	59.8	45.1	36.1	30.1
	240	70.5	59.8	45.1	36.1	30.1	77.0	59.8	45.1	36.1	30.1	77.0	59.8	45.1	36.1	30.1
	250	73.0	59.8	45.1	36.1	30.1	77.0	59.8	45.1	36.1	30.1	77.0	59.8	45.1	36.1	30.1
HSD-CRET 124 V	200	52.4	52.4	52.4	46.8	39.0	64.8	64.8	58.5	46.8	39.0	75.4	75.4	58.5	46.8	39.0
	220	65.4	65.4	58.5	46.8	39.0	80.7	76.3	58.5	46.8	39.0	93.7	76.3	58.5	46.8	39.0
	240	70.6	70.6	58.5	46.8	39.0	87.4	76.3	58.5	46.8	39.0	95.1	76.3	58.5	46.8	39.0
	250	84.3	76.3	58.5	46.8	39.0	95.1	76.3	58.5	46.8	39.0	95.1	76.3	58.5	46.8	39.0
	260	87.6	76.3	58.5	46.8	39.0	95.1	76.3	58.5	46.8	39.0	95.1	76.3	58.5	46.8	39.0
HSD-CRET 128 V	240	81.5	81.5	81.5	74.4	62.0	101.3	101.3	92.9	74.4	62.0	118.2	114.8	92.9	74.4	62.0
	250	84.9	84.9	84.9	74.4	62.0	105.7	105.7	92.9	74.4	62.0	123.5	114.8	92.9	74.4	62.0
	260	88.3	88.3	88.3	74.4	62.0	110.0	110.0	92.9	74.4	62.0	128.7	114.8	92.9	74.4	62.0
	280	111.6	111.6	92.9	74.4	62.0	136.8	114.8	92.9	74.4	62.0	136.8	114.8	92.9	74.4	62.0
	300	119.2	114.8	92.9	74.4	62.0	136.8	114.8	92.9	74.4	62.0	136.8	114.8	92.9	74.4	62.0
	320	121.5	114.8	92.9	74.4	62.0	136.8	114.8	92.9	74.4	62.0	136.8	114.8	92.9	74.4	62.0
	340	128.8	114.8	92.9	74.4	62.0	136.8	114.8	92.9	74.4	62.0	136.8	114.8	92.9	74.4	62.0
HSD-CRET 134 V	300	155.1	155.1	155.1	133.1	110.9	193.7	186.4	159.8	133.1	110.9	213.1	186.4	159.8	133.1	110.9
	320	157.7	157.7	157.7	133.1	110.9	197.1	186.4	159.8	133.1	110.9	213.1	186.4	159.8	133.1	110.9
	340	167.8	167.8	159.8	133.1	110.9	210.2	186.4	159.8	133.1	110.9	213.1	186.4	159.8	133.1	110.9
	350	172.8	172.8	159.8	133.1	110.9	213.1	186.4	159.8	133.1	110.9	213.1	186.4	159.8	133.1	110.9
	360	177.7	177.7	159.8	133.1	110.9	213.1	186.4	159.8	133.1	110.9	213.1	186.4	159.8	133.1	110.9
HSD-CRET 140 V	350	182.5	182.5	182.5	182.5	180.7	229.6	229.6	229.6	211.9	180.7	270.3	270.3	243.3	211.9	180.7
	360	187.5	187.5	187.5	187.5	180.7	236.0	236.0	236.0	211.9	180.7	278.0	274.6	243.3	211.9	180.7
	380	197.4	197.4	197.4	197.4	180.7	248.8	248.8	243.3	211.9	180.7	293.4	274.6	243.3	211.9	180.7
	400	207.1	207.1	207.1	207.1	180.7	261.4	261.4	243.3	211.9	180.7	305.9	274.6	243.3	211.9	180.7
	450	230.8	230.8	230.8	211.9	180.7	292.3	274.6	243.3	211.9	180.7	305.9	274.6	243.3	211.9	180.7
HSD-CRET 140 V ②	380	233.9	233.9	233.9	211.9	180.7	291.2	274.6	243.3	211.9	180.7	305.9	274.6	243.3	211.9	180.7
	400	246.5	246.5	243.3	211.9	180.7	305.9	274.6	243.3	211.9	180.7	305.9	274.6	243.3	211.9	180.7
	450	277.1	274.6	243.3	211.9	180.7	305.9	274.6	243.3	211.9	180.7	305.9	274.6	243.3	211.9	180.7

① Load-bearing capacities for concrete strengths C25/30 and C35/40 can be interpolated. ② Values apply for increased reinforcement according to the table on page 12

= steel load-bearing capacity decisive

= Concrete edge failure decisive

= Punching failure decisive

A separate proof of the load-bearing capacity of the concrete (punching shear failure and concrete edge failure) is to be carried out:

- in case of deviating reinforcement in the punching cone
- If the dowel spacings are below the critical minimum limit
- when using for larger slab thicknesses

Dimensioning of the joint width f
 $f = \text{calculated joint width} + \text{safety supplement (approx. 1cm)}$

HALFEN HSD SHEAR DOWEL SYSTEM

Heavy-duty shear dowels

In-situ reinforcement

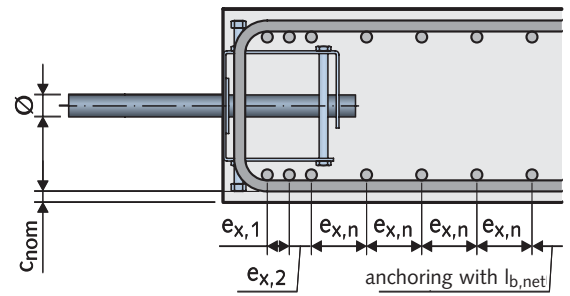
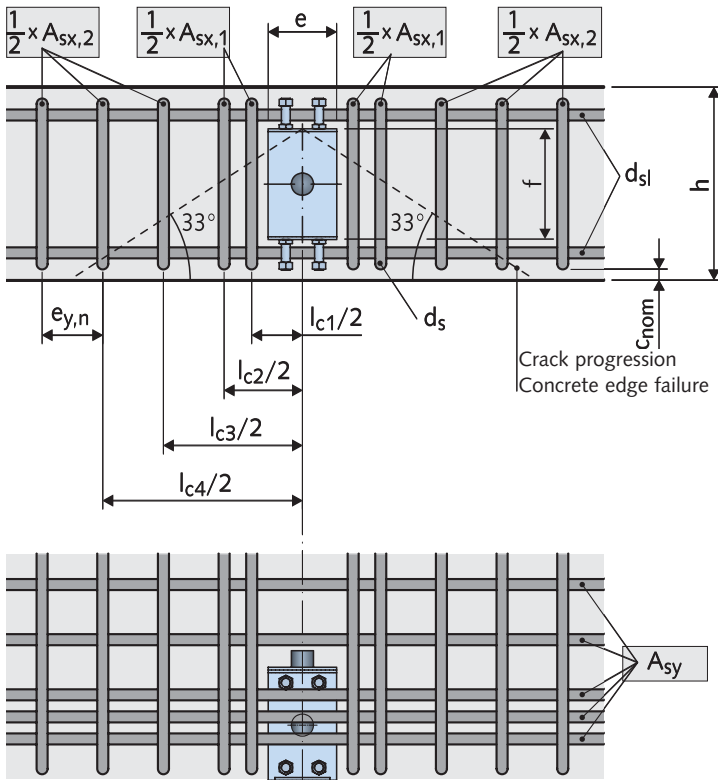

- $A_{sx,1}$ Stirrup on both sides as a vertical suspension reinforcement
- $A_{sx,2}$ Stirrup on both sides in the punching failure area
- A_{sy} Longitudinal reinforcement parallel to the edge, placed above and below

Installation dimensions

Minimum spacings

HSD-CRET-	HSD-CRET-	Dowel diameter [mm]	Minimum component thickness h_{min} [cm]	Critical dowel spacing ① $e = 3 \times d_m + l_{c1}$ [cm]	Minimum dowel spacing $e_{min} = 1,5 \times h_{min}$ [cm]	Minimum edge distance $a_r = 0,75 \times h_{min}$ [cm]
122	122 V	22	18	54	27	14
124	124 V	24	20	60	30	15
128	128 V	28	24	73	36	18
134	134 V	34	30	91	45	23
140	140 V	40	35	108	53	26

In order to obtain a linear support, it is recommended that the centre spacing of the dowels should not be above the limit of $5 \times h$.

① If the dowel spacings are below the applicable table value for the critical dowel spacing, a separate punching load proof according to DIN 1045-1 is to be carried out.

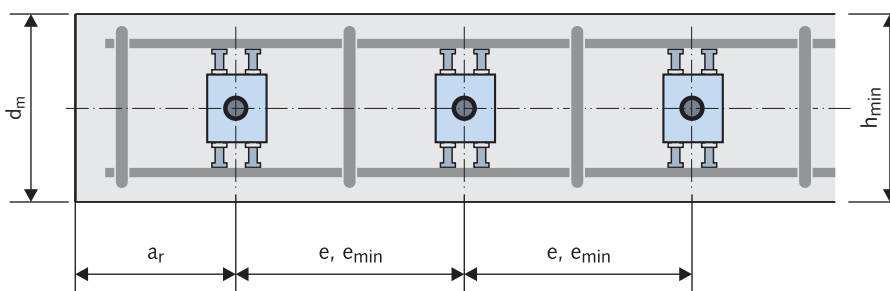

- e = centre spacing between the dowels
- e_{min} = minimum dowel spacing
- a_r = minimum edge spacing
- d_m = average static height

HALFEN HSD SHEAR DOWEL SYSTEM

Heavy-duty shear dowels

In-situ reinforcement

Heavy-duty shear dowels HSD-CRET longitudinal movement

Type	Component thickness [mm]	c _{nom} [mm]	Reinforcement spacings [mm]							In-situ reinforcement				
			l _{c1/2}	l _{c2/2}	l _{c3/2}	l _{c4/2}	e _{y,n}	e _{x,1}	e _{x,2}	e _{x,n}	A _{sx,1}	A _{sx,2}	A _{sy} ③	
HSD-CRET 122	180	25	55	87	137	187	—	50	—	—	4 Ø 12	4 Ø 12	2 Ø 12	
	200			89	139	189					4 Ø 14	4 Ø 14	2 Ø 14	
	220	30		91	141	191	150		4 Ø 16		4 Ø 16	2 Ø 16		
	240			89	139	189	150		6 Ø 14		4 Ø 14	3 Ø 14		
	250	25		89	139	189	150		6 Ø 14		4 Ø 14	3 Ø 14		
HSD-CRET 124	200	25	60	94	144	194	—	50	—	—	4 Ø 14	4 Ø 14	2 Ø 14	
	220	30		96	146	196					4 Ø 16	4 Ø 16	2 Ø 16	
	240	25		94	144	194	150		100		6 Ø 14	4 Ø 14	3 Ø 14	
	250			96	146	196					150	6 Ø 16	4 Ø 16	3 Ø 16
	260	30		96	146	196	150		100		150	6 Ø 16	4 Ø 16	3 Ø 16
	280			96	146	196	150		150		6 Ø 16	4 Ø 16	3 Ø 16	
HSD-CRET 128	240	25	65	99	149	199	70	50	100	—	6 Ø 14	6 Ø 14	3 Ø 14	
	250	30		101	151	201				120	6 Ø 16	6 Ø 16	4 Ø 16	
	260			101	151	201				150	8 Ø 16	8 Ø 16	4 Ø 16	
	280	25		99	149	199			100	100	8 Ø 14	6 Ø 14	5 Ø 14	
	300	25		99	149	199			50	150	100	8 Ø 14	6 Ø 14	5 Ø 14
	320			115	165	215					150	8 Ø 16	8 Ø 16	5 Ø 16
	340			115	165	215					150	8 Ø 16	8 Ø 16	5 Ø 16
HSD-CRET 134	300	30	75	111	161	211	50	50	50	70	8 Ø 16	8 Ø 16	6 Ø 16	
	320			111	161	211	50					6 Ø 16	6 Ø 16	
	340			125	175	225	70					8 Ø 16	8 Ø 16	7 Ø 16
	350			125	175	225	70					8 Ø 16	8 Ø 16	8 Ø 16
	360			125	175	225	70					8 Ø 16	8 Ø 16	8 Ø 16
HSD-CRET 140	350	30	85	135	185	235	70	50	50	70	8 Ø 16	8 Ø 16	7 Ø 16	
	360											8 Ø 16	8 Ø 16	
	380											10 Ø 16	8 Ø 16	
	400											10 Ø 16	8 Ø 16	
	450											12 Ø 16	9 Ø 16	
HSD-CRET 140 ②	350	30	85	135	185	235	70	50	50	70	8 Ø 20	8 Ø 20	7 Ø 20	
	360											8 Ø 20	8 Ø 20	
	380											10 Ø 20	8 Ø 20	
	400											10 Ø 20	8 Ø 20	
	450											12 Ø 20	9 Ø 20	
		35	90	140	190	240					8 Ø 25	12 Ø 25	9 Ø 25	

② Increased reinforcement for higher load-bearing capacity according to table on page 8

③ In-situ reinforcement A_{sy} placed above and below

HALFEN HSD SHEAR DOWEL SYSTEM

Heavy-duty shear dowels

In-situ reinforcement

Heavy-duty shear dowels HSD-CRET V longitudinal and transverse movement

Type	Component thickness [mm]	c _{nom} [mm]	Reinforcement spacings [mm]								In-situ reinforcement			
			l _{c1/2}	l _{c2/2}	l _{c3/2}	l _{c4/2}	e _{y,n}	e _{x,1}	e _{x,2}	e _{x,n}	A _{sx,1}	A _{sx,2}	A _{sy} ③	
HSD-CRET 122V	180	25	65	97	147	197	—	—	—	—	4 Ø 12	4 Ø 12	1 Ø 12	
	200			104	154	204					4 Ø 14	4 Ø 14	1 Ø 14	
	220	30	70	106	156	206	150	—	—	—	4 Ø 16	4 Ø 16	1 Ø 16	
	240										6 Ø 14	—	—	
	250										—	—	—	
HSD-CRET 124V	200	25	70	104	154	204	—	—	—	—	4 Ø 14	4 Ø 14	1 Ø 14	
	220	30	75	111	161	211	—	—	—	—	4 Ø 16	4 Ø 16	1 Ø 16	
	240										6 Ø 16	—	—	
	250	25	70	104	154	204	150	50	—	—	6 Ø 14	4 Ø 14	2 Ø 14	
	260	30	75	111	161	211	—	—	—	—	6 Ø 16	4 Ø 16	2 Ø 16	
280	—										—	—		
HSD-CRET 128V	240	25	80	114	164	214	70	—	—	—	—	6 Ø 14	6 Ø 14	2 Ø 14
	250													
	260													
	280													
	300													
	320	90	126	176	226	70	50	50	120	8 Ø 16	6 Ø 16	5 Ø 16		
340	8 Ø 16										—			
360	—	—	—	—										
HSD-CRET 140V	350	30	100	150	200	250	70	50	50	100	8 Ø 16	8 Ø 16	6 Ø 16	
	360											10 Ø 16	7 Ø 16	
	380	35	105	155	205	255	70	50	50	100	8 Ø 20	10 Ø 16	—	
	400											12 Ø 16	7 Ø 16	
	450											—	—	
HSD-CRET 140V ②	450	35	190	240	—	—	—	—	—	—	8 Ø 25	12 Ø 25	7 Ø 25	

② Increased reinforcement for higher load-bearing capacity according to the table on page 9

③ In-situ reinforcement A_{sy} placed above and below

HALFEN HSD SHEAR DOWEL SYSTEM

Heavy-duty shear dowels

Assembly instructions for HALFEN HSD-CRET heavy-duty shear dowels

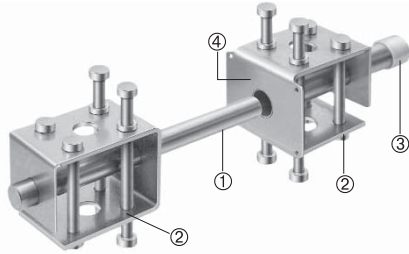

- ① Dowel
- ② Load distribution body
- ③ Sliding socket
- ④ Nail plate for the fixation of the socket to the formwork



HSD-CRET sliding sockets nailed onto the formwork

First concreting section

The sliding sockets are fixed to the formwork by nailing (Illustrations 1 and 2); in doing this, it must be ensured that the sockets are exactly aligned in the sliding direction.

The label applied over the opening in the socket protects the socket against the entry of concrete, and must therefore not be removed.

The in-situ junction and suspension reinforcement is to be installed according to the information from the static calculations and the reinforcement plan.

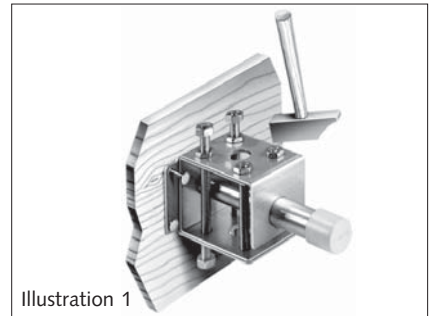

Illustration 1

Second concreting section

After removing the formwork from the first concreting section, the filling material is placed into the joint (Illustration 3). The joint width specified in the plan must be complied with exactly.

A recess in the filling material has to be provided so that the dowels can be inserted into the sockets. The required joint reinforcement is to be installed according to the data from the static plan and the reinforcement plans. The use of the shear dowels without additional measures for environmental conditions according to DIN 1045-1 is permissible.

In the case of environmental conditions with higher requirements on corrosion protection, the dowels and the sliding sockets are to be well coated with a corrosion protection compound, e.g. on a petroleum basis. If a higher fire resistance duration is specified in the reinforcement plan, non-inflammable material must be used as filling material in the joints (e.g. mineral fibre with a relative density of approx. 110 kg/m³ according to DIN 4102 T 4).

If there are fire protection requirements on the construction components according to DIN 4102 T.2, we recommend the installation of the HALFEN HSD shear dowels with fire protection pad (see page 5).

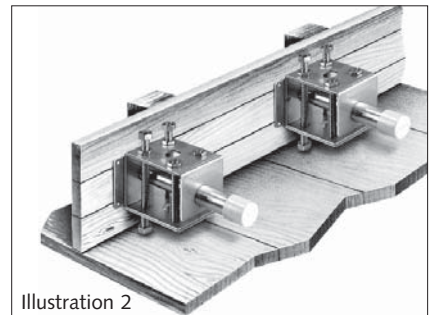

Illustration 2

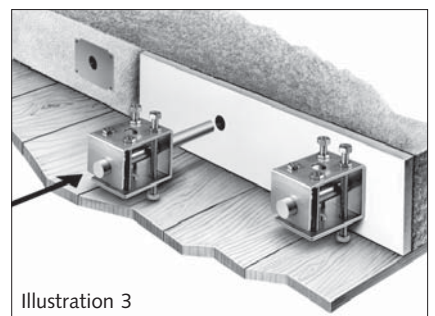
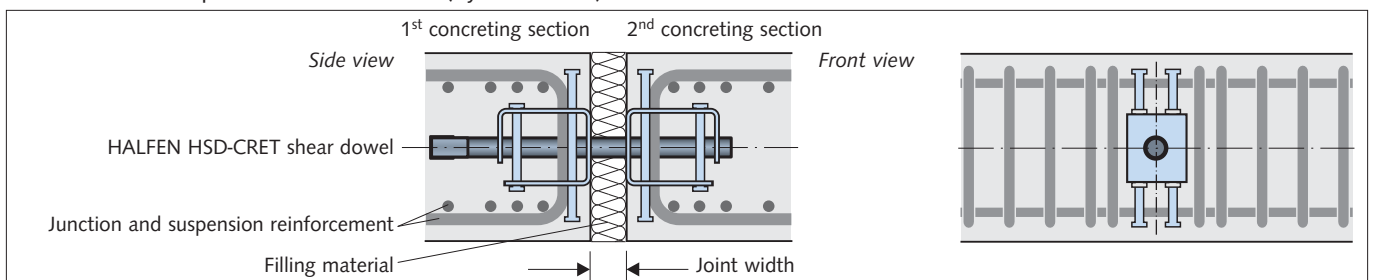

Illustration 3

Additional and suspension reinforcement (by contractor)



HALFEN HSD SHEAR DOWEL SYSTEM

Single shear dowels

Product description

HALFEN Single shear dowels HSD allow sliding in the direction of the member axis. The dowels are normally used to transmit shear loads in any direction.
 If lateral movements have to be taken into account, the HSD-SV sockets are used, which permit a sideways movement, i.e. the shear load will only be transmitted in one direction.

Note: HALFEN single shear dowels HSD are not subject to a technical approval!

Socket HSD-S

(longitudinal movement)

Material: Stainless steel A2

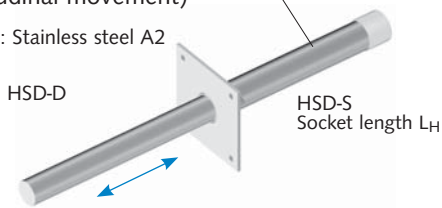

Single shear dowel HSD-D

Material / finish:

A4 = Stainless steel grade 1.4571/1.4462

FV = Steel S355, hot-dip galvanised
 (only in combination with socket -P = plastic)

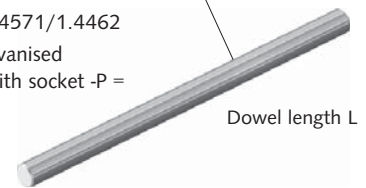

Socket HSD-SV

(longitudinal and transverse movement)

Material: Stainless steel A2

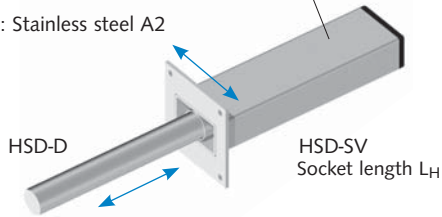

Socket HSD-P

(longitudinal movement)

Material: Plastic (only in combination with dowel in material / finish FV)

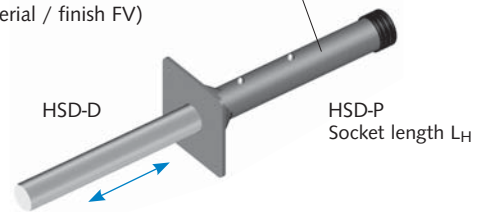

Dimensions of single shear dowels and sockets

Dowel type	Single shear dowel		Sliding sockets HSD-P, -S		Sliding sockets HSD-SV	
	Dowel Ø [mm]	Dowel length L [mm]	Socket length L _H [mm]	Nail plate width/height [mm]	Socket length L _H [mm]	Nail plate width/height [mm]
HSD-D 20	20	300	160	70/70	180	80/80
HSD-D 22	22	300	160	70/70	180	80/80
HSD-D 25	25	300	160	70/70	180	80/80
HSD-D 30	30	350	185	80/80	205	100/80

Ordering examples:

• Dowel:

HSD-D 22 -A4
 HALFEN shear dowel
 Diameter [mm]
 A4 = Stainless steel A4 material

• Sliding socket:

HSD-SV 22
 HALFEN sliding socket
 - S = Stainless steel A2
 - SV = ditto, transverse and longitudinal movement
 - P = Plastic
 for dowel diameter [mm]

• Set (Dowel + sliding socket) **HSD-SET 22 V -A4**

HALFEN shear dowel set
 with dowel diameter [mm]
 V = Socket transverse and longitudinal movement
 A4 = Dowel stainless steel A4,
 Socket S/SV = stainless steel A2

HALFEN HSD SHEAR DOWEL SYSTEM

Single shear dowels

Dimensioning

Minimum spacing, Element thickness, Stirrup spacing						
Dowel Ø	Socket	Stirrup Ø	Component thickness	Stirrup spacing	Required dowel spacing	Edge distance
[mm]		d_s [mm]	h_{min} [mm]	l_c [mm]	e_{min} [mm]	a_r [mm]
20	HSD-S + HSD-P	10	160	60	310	160
22		10	160	60	350	175
25		12	175	70	410	200
30		14	210	90	560	240
20	HSD-SV	10	160	80	310	160
22		10	160	90	350	175
25		12	175	100	410	200
30		14	210	110	560	240

l_c = Distance of the first stirrup from the dowel
 h_{min} = Minimum component thickness
 e_{min} = Minimum centre spacing between the single dowels
 a_r = Minimum edge distance

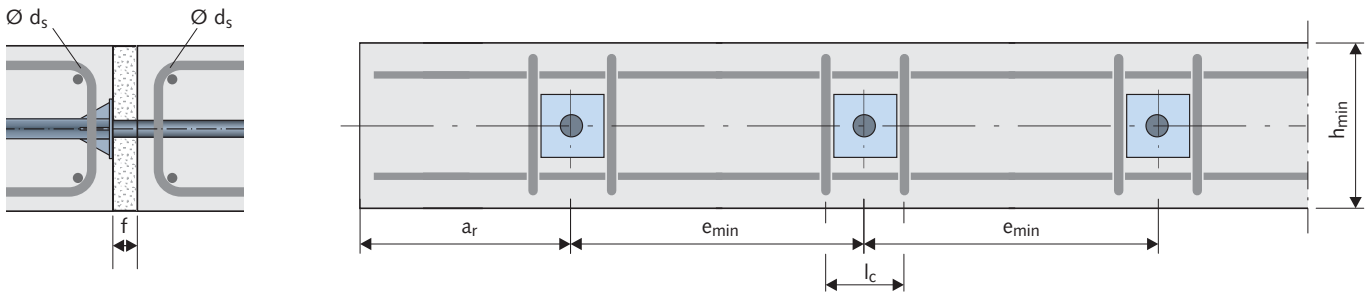

Dimensioning for non-reinforced concrete

Design resistances HSD-D in non-reinforced concrete according to volume 346, DAfStb (German association for reinforced concrete construction)

Steel load-bearing capacity: $V_{Rd,s} = f_{\mu} \times 1,25 \times (f_{yk} / \gamma_{MS}) \times W / (f + \varnothing)$

Concrete load-bearing capacity: $V_{Rd,c} = 0,4 \times f_{ck} \times \varnothing^{2,1} / (333 + 12,2 \times f)$
 $0,4 = (\alpha \times \gamma_{MW}) / 3$

with:

- f_{μ} = 0,9 Reductions factor due to friction [-]
- f_{yk} = Yielding point [N/mm²]
- f_{ck} = characteristic cylinder resistance to pressure of the concrete [N/mm²]
- f = Joint width [mm]
- \varnothing = Shear dowel diameter [mm]
- W = Section modulus [mm³]
- γ_{MS} = Material safety factor for steel [-]
- HALFEN Single shear dowels HSD-D require no official approval.
- $\alpha = 0,85$ (consideration of the long-term effects)
- $\gamma_{MW} = 1,425$ (average value from $\gamma_G = 1,35$ and $\gamma_Q = 1,5$)
- Minimum edge distance to the dowel axis $a_r = 8 \times \varnothing$ (in all directions)
- Minimum axial distance $e = 16 \times \varnothing$

Dimensioning resistances $V_{Rd,s}$ and $V_{Rd,c}$ [kN] for non-reinforced concrete

Dowel type	Concrete grade	Dowel-Ø [mm]	Minimum component thickness [mm]	Design resistances [kN] for joint width f [mm]			
				10	20	30	40
HSD-D 20	≥ C20/25	20	320	9.5	7.1	5.7	4.8
HSD-D 22		22	350	11.6	9.0	7.3	6.1
HSD-D 25		25	400	15.2	12.0	9.9	8.4
HSD-D 30		30	480	22.2	17.5	14.5	12.3

HALFEN HSD SHEAR DOWEL SYSTEM

Single shear dowels

Dimensioning for reinforced concrete

Design resistances HSD-D in reinforced concrete according to volume 346, DAfStb (German association for reinforced concrete construction)

Required certifications:

Certification against punching failure $V_{Rd,ct}$

(acc. to DIN 1045-1)

Certification against concrete edge failure $V_{Rd,ce}$

(acc. to volume 346, DAfStb)

Nachweis der Stahltragfähigkeit $V_{Rd,s}$

Steel load-bearing capacity:

$$V_{Rd,s} = f_{\mu} \times 1,25 \times (f_{yk} / \gamma_{MS}) \times W / (f + \varnothing / 2)$$

$$V_{Rd} = \min (V_{Rd,s}; V_{Rd,c})$$

$V_{Rd,s}$ Dimensioning resistance of the steel load-bearing capacity

$V_{Rd,c}$ Dimensioning resistance of the concrete load-bearing capacity

mit:

f_{μ} = Reduction factor due to friction [-]

f_{yk} = Yielding point [N/mm²]

f = Joint width [mm]

\varnothing = Shear dowel diameter [mm]

W = Section modulus [mm³]

γ_{MS} = Material safety factor for steel [-]

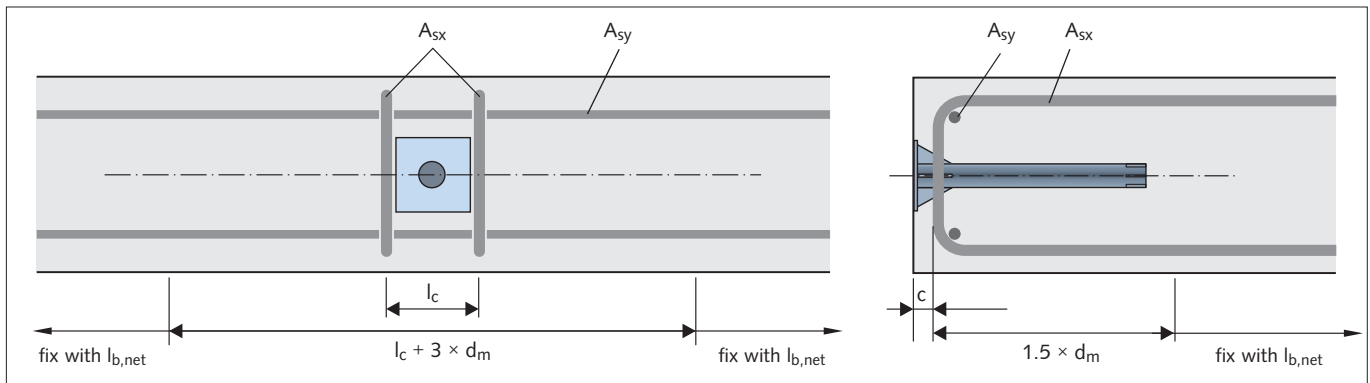

Proof of the steel load-bearing capacity

Design resistances $V_{Rd,s}$ for HSD-S and HSD-P -longitudinal movement - for reinforced concrete

Dowel type	Dowel- \varnothing [mm]	Design resistances $V_{Rd,s}$ [kN] for joint width f [mm]			
		10 mm	20 mm	30 mm	40 mm
HSD-D 20	20	14.3	9.5	7.1	5.7
HSD-D 22	22	18.1	12.2	9.3	7.4
HSD-D 25	25	24.8	17.1	13.1	10.6
HSD-D 30	30	38.5	27.5	21.4	17.5

taking account of friction ($f_{\mu} = 0,9$)

Design resistances $V_{Rd,s}$ for HSD-SV -longitudinal and transverse movement- for reinforced concrete

Dowel type	Dowel- \varnothing [mm]	Design resistances $V_{Rd,s}$ [kN] for joint width f [mm]			
		10 mm	20 mm	30 mm	40 mm
HSD-D 20	20	12.8	8.6	6.4	5.1
HSD-D 22	22	16.3	11.0	8.3	6.7
HSD-D 25	25	22.3	15.4	11.8	9.5
HSD-D 30	30	34.6	24.7	19.2	15.7

taking account of friction ($f_{\mu} = 0,81$)

HALFEN HSD SHEAR DOWEL SYSTEM

Single shear dowels

Dimensioning for reinforced concrete

Proof of the concrete load-bearing capacity

The design resistance for the concrete load-bearing capacity is the smallest dimensioning resistance from the concrete edge failure and punching failure proofs:

A_{sx} = Rear suspension reinforcement

A_{sy} = Longitudinal reinforcement

l_c = Distance of the first stirrup to the dowel

Dimensioning resistances $V_{Rd,c}$ for HSD-S and HSD-P -longitudinal movement -

Dowel type	Component thickness h [mm]	c_{nom} [mm]	Design resistances $V_{Rd,c}$ [kN] $\geq C20/25$	In-situ reinforcement		Centre spacing l_c [mm]
				A_{sx}	A_{sy}	
HSD-D 20	≥ 160	30	14.2	2 Ø 10	2 Ø 10	60
	≥ 180		15.8			
HSD-D 22	≥ 160	30	14.2	2 Ø 10	2 Ø 10	60
	≥ 180		15.8			
	≥ 200		17.3			
	≥ 220		18.9			
	≥ 240		20.4			
HSD-D 25	≥ 180	30	20.5	2 Ø 12	2 Ø 12	70
	≥ 200		22.4			
	≥ 220		24.3			
	≥ 240		26.2			
	≥ 260		28.0			
HSD-D 30	≥ 220	30	29.3	2 Ø 14	2 Ø 14	90
	≥ 240		31.5			
	≥ 260		33.7			
	≥ 280		35.9			
	≥ 300		38.1			
	≥ 320		40.2			

taking account of friction ($f_{\mu} = 1,0$)

Dimensioning resistances $V_{Rd,c}$ for HSD-SV -longitudinal and transverse movement-

Dowel type	Component thickness h [mm]	c_{nom} [mm]	Design resistances $V_{Rd,c}$ [kN] $\geq C20/25$	In-situ reinforcement		Centre spacing l_c [mm]
				A_{sx}	A_{sy}	
HSD-D 20	≥ 160	30	⁵⁾	2 Ø 10	2 Ø 10	80
	≥ 180		13.0			
HSD-D 22	≥ 160	30	⁵⁾	2 Ø 10	2 Ø 10	90
	≥ 180		12.5			
	≥ 200		13.9			
	≥ 220		15.3			
HSD-D 25	≥ 240	30	16.7	2 Ø 12	2 Ø 12	100
	≥ 180		⁵⁾			
	≥ 200		18.0			
	≥ 220		19.8			
HSD-D 30	≥ 240	30	21.5	2 Ø 14	2 Ø 14	110
	≥ 260		23.2			
	≥ 220		24.6			
	≥ 240		26.7			
	≥ 260		28.7			
HSD-D 30	≥ 280	30	30.7	2 Ø 14	2 Ø 14	110
	≥ 300		32.7			
	≥ 320		34.7			
	≥ 300		32.7			

taking account of friction ($f_{\mu} = 0,9$) ⁵⁾ No rear suspension stirrup in the break-out cone

HALFEN HSD SHEAR DOWEL SYSTEM

Single shear dowels

Assembly instructions for HSD single shear dowels

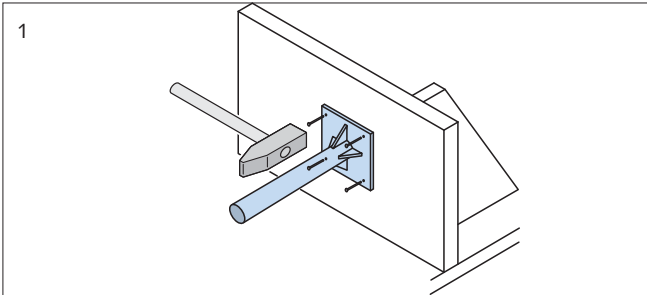

1. Fixing to the formwork

Nail the socket onto the formwork according to the specified position. Important: The socket must be aligned exactly in the direction of slide.

NOTE: Do not remove the label. This protects the socket from the penetration of fresh concrete.

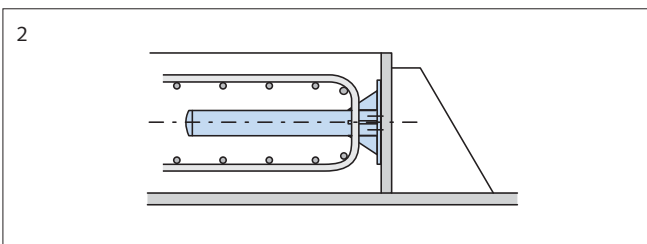

2. Reinforcement

Laying of the in-situ joint and rear suspension reinforcement, as well as the component reinforcement, in the 1st concreting-section.

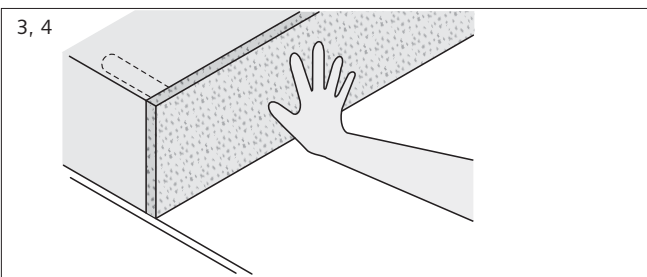

3. Protective label

The protective label can be removed from the socket after the concreting and the removal of the formwork.

4. Joint material

Application of the joint material. The positions of the shear dowel sockets are to be exactly marked where necessary.

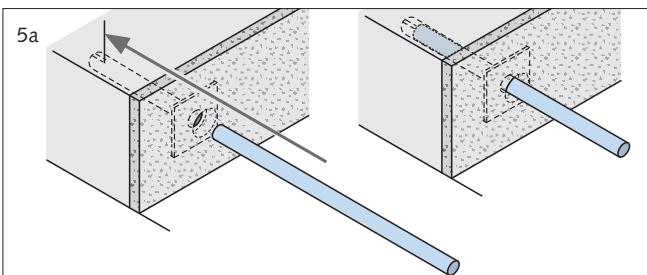

5. a) Shear dowel

The dowel that matches the socket is now inserted through the joint material and is pushed into the socket up to the stop (safety plug).

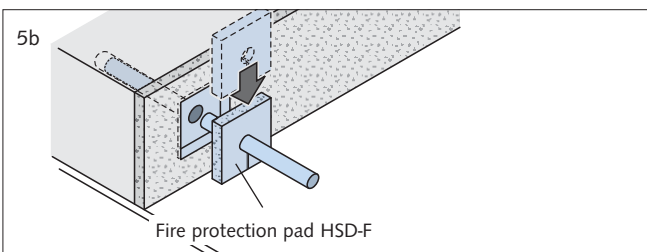

5. b) Shear dowel

In the case of fire protection requirements according to DIN 4102, a recess is to be provided in the joint material for the HALFEN fire protection pad.

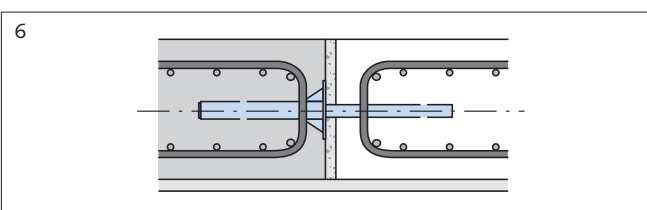

6. Concreting

Positioning of the reinforcement (by contractor) and concreting the 2nd concreting-section.

CONTACT HALFEN WORLDWIDE

HALFEN is represented with subsidiaries in the following 14 countries, please contact us:

Austria	HALFEN Gesellschaft m.b.H. Leonard-Bernstein-Str. 10 1220 Wien	Phone: +43 - 1 - 259 6770 E-Mail: office@halfen.at Internet: www.halfen.at	Fax: +43 - 1 - 259 - 6770 99
Belgium/Luxembourg	HALFEN-FRIMEDA N.V. Borkestraat 131 2900 Schoten	Phone: +32 - 3 - 658 07 20 E-Mail: info@halfen.be Internet: www.halfen.be	Fax: +32 - 3 - 658 15 33
China	HALFEN Construction Accessories Distribution Co.Ltd. Room 601 Tower D, Vantone Centre No.A6 Chao Yang Men Wai Street Chaoyang District Beijing · P.R. China 100020	Phone: +86 - 10 5907 3200 E-Mail: info@halfen.com Internet: www.halfen.cn	Fax: +86 - 10 5907 3218
Czech Republic	HALFEN-DEHA s.r.o. K Vypichu 986 · Komerční zóna Rudná, hala 6 25219 Rudná	Phone: +420 - 311 - 690 060 E-Mail: info@halfen-deha.cz Internet: www.halfen-deha.cz	Fax: +420 - 311 - 671 416
France	HALFEN S.A.S. 18, rue Goubet 75019 Paris	Phone: +33 - 1 - 445231 00 E-Mail: halfen@halfen.fr Internet: www.halfen.fr	Fax: +33 - 1 - 445231 52
Germany	HALFEN-DEHA Vertriebsgesellschaft mbH Katzbergstraße 3 40764 Langenfeld	Phone: +49 - 2173 - 970 0 E-Mail: info@halfen.de Internet: www.halfen.de	Fax: +49 - 2173 - 970 225
Italy	HALFEN-DEHA S.r.l. Soc. Unipersonale Via F.lli Bronzetti N° 28 24124 Bergamo	Phone: +39 - 035 - 0760711 E-Mail: info@halfen.it Internet: www.halfen.it	Fax: +39 - 035 - 0760799
Netherlands	HALFEN b.v. Vonderweg 5 7468 DC Enter	Phone: +31 - 547 - 3830 30 E-Mail: info@halfen.nl Internet: www.halfen.nl	Fax: +31 - 547 - 3830 35
Norway	HALFEN-FRIMEDA AS Postboks 2080 4095 Stavanger	Phone: +47 - 51 82 34 00 E-Mail: post@halfen.no Internet: www.halfen.no	Fax: +47 - 51 82 34 01
Poland	HALFEN Sp. z o.o. Ul. Obornicka 287 60-691 Poznan	Phone: +48 - 61 - 622 14 14 E-Mail: info@halfen.pl Internet: www.halfen.pl	Fax: +48 - 61 - 622 14 15
Spain	HALFEN-DEHA S.L. c/ Fuente de la Mora 2, 2° D 28050 Madrid	Phone: +34 - 91 - 632 18 40 E-Mail: info@halfen.es Internet: www.halfen.es	Fax: +34 - 91 - 633 42 57
Sweden	HALFEN AB Box 150 435 23 Mölnlycke	Phone: +46 - 31 - 98 58 00 E-Mail: info@halfen.se Internet: www.halfen.se	Fax: +46 - 31 - 98 58 01
Switzerland	HALFEN Swiss AG Industriestrasse 32 8108 Dällikon	Phone: +41 - 44 - 849 78 78 E-Mail: mail@halfen.ch Internet: www.halfen.ch	Fax: +41 - 44 - 849 78 79
United Kingdom / Ireland	HALFEN Ltd. Humphrys Road · Woodside Estate Dunstable LU5 4TP	Phone: +44 - 1582 - 47 03 00 E-Mail: info@halfen.co.uk Internet: www.halfen.co.uk	Fax: +44 - 1582 - 47 03 04

Furthermore HALFEN is represented with sales offices and distributors worldwide. Please contact us: www.halfen.com

NOTES REGARDING THIS CATALOGUE

Technical and design changes reserved. The information in this publication is based on state-of-the-art technology at the time of publication. We reserve the right to make technical and design changes at any time. Halfen GmbH shall not accept liability for the accuracy of the information in this publication or for any printing errors.

The Quality Management System of Halfen GmbH is certified for the locations in Germany, Switzerland and Poland according to **DIN EN ISO 9001:2000**, Certificate No. QS-281 HH.





For further information please contact: www.halfen.com



CAST·IN

CAST-IN PORTUGAL
Unipessoal, Lda.

+351 969 769 742 | +351 252 858 539
Rua Cidade Barcelos 65, R/C Dto. 4490-198 Póvoa de Varzim
geral@cast-in.pt
www.cast-in.pt